

CITY OF AUMSVILLE
Public Works Design Standards

Standard Detail Drawings & Sample Test Report Forms
Appendix A

Note:

- 1) Per PWDS 1.11.b.11, the applicable City standard details shall be included on construction drawings submitted for City review and approval. See also PWDS 1.3.a.3 for detail sheet stamping requirements where engineered drawings are required.
- 2) Per PWDS 1.2.b, the City standard details are intended to assist but not to substitute for competent work by design professionals where applicable. As noted in the PWDS, the City standard details illustrate the minimum requirements and materials required by the Public Works Department for the construction of certain standard system components, and are thus not considered to be final documents until incorporated into a design approved by the City,

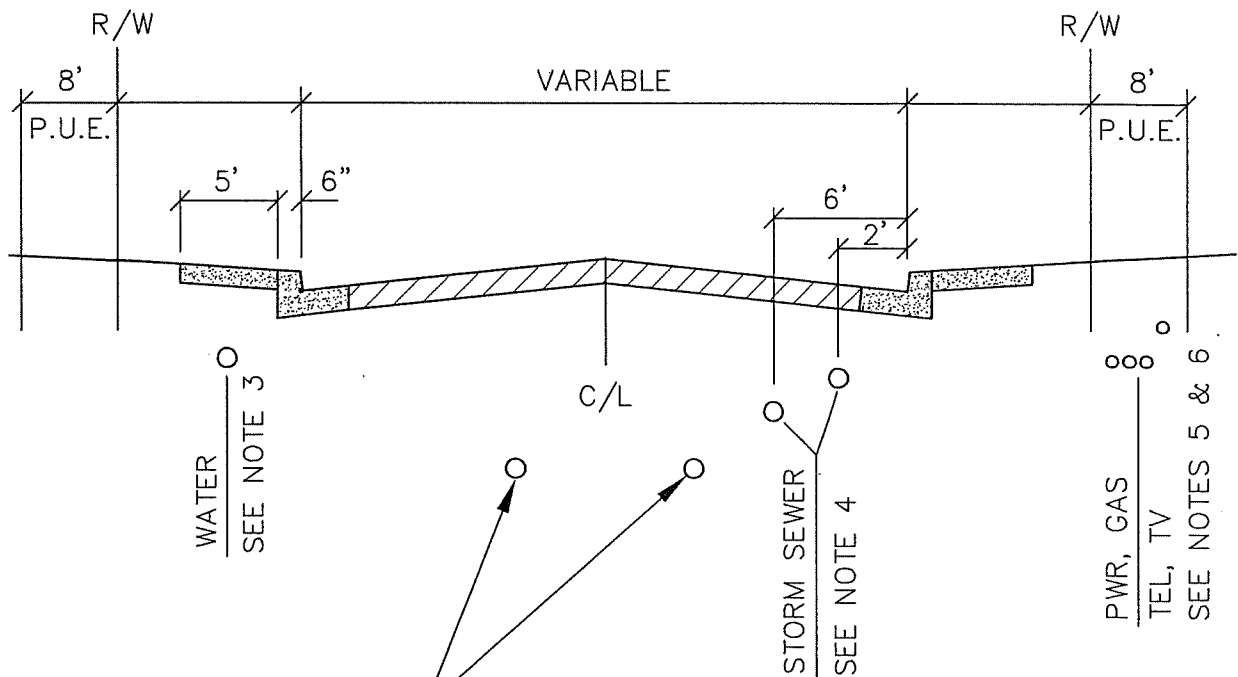

S.S. - 5' FROM C/L (TYP ON LOW SIDE OF STREET).
 SEE NOTES 1 & 2 (3' MIN CLEAR SEPARATION BETWEEN SEWER & STORM MAINS)

CURBED STREETS

NTS

NOTES:

1. 6' MIN COVER REQUIRED FOR SANITARY SEWER MAINS (4' MIN. COVER TYPICALLY REQUIRED FOR LATERALS).
2. LATERALS AND P/L CLEANOUTS TO BE INSTALLED DURING CONSTRUCTION OF SANITARY SEWER & STORM MAINS (TO AVOID FUTURE STREET CUTS).
3. WATER TO BE INSTALLED 3' BEHIND FACE OF CURB ON HIGH SIDE OF STREET. 36" MIN. COVER ON ALL WATERLINES. 10' MINIMUM SEPARATION TYPICAL BETWEEN PARALLEL WATER & SEWER MAINS.
4. STORM SEWER TO BE INSTALLED ON LOW SIDE OF STREET:
 - a) 2' FROM FACE OF CURB FOR <4' RIM TO INVERT
 - b) 6' FROM FACE OF CURB FOR >4' RIM TO INVERT (MH SYSTEM)
5. MAINTAIN MIN. 5' HORIZ. SEPARATION BETWEEN PUBLIC UTILITIES & PARALLEL PRIVATE UTILITIES. OTHER VERTICAL AND HORIZONTAL SEPARATION DISTANCES SHALL BE AS SPECIFIED BY DEQ, ODWP, OR OTHER PUBLIC/PRIVATE UTILITY COMPANIES.
6. UNITY TRENCH PER FRANCHISE UTILITY COMPANY REQUIREMENTS, GENERALLY ON OPPOSITE SITE OF STREET FROM WATER LINE WHERE FEASIBLE.

LAST REVISION DATE: AUG 2022	COPYRIGHT 1996 WESTECH ENGINEERING, INC.
TYP. UTILITY LOCATIONS (CURBED STREETS)	
(NTS)	
AUMSVILLE, OR	DETAIL NO. 101

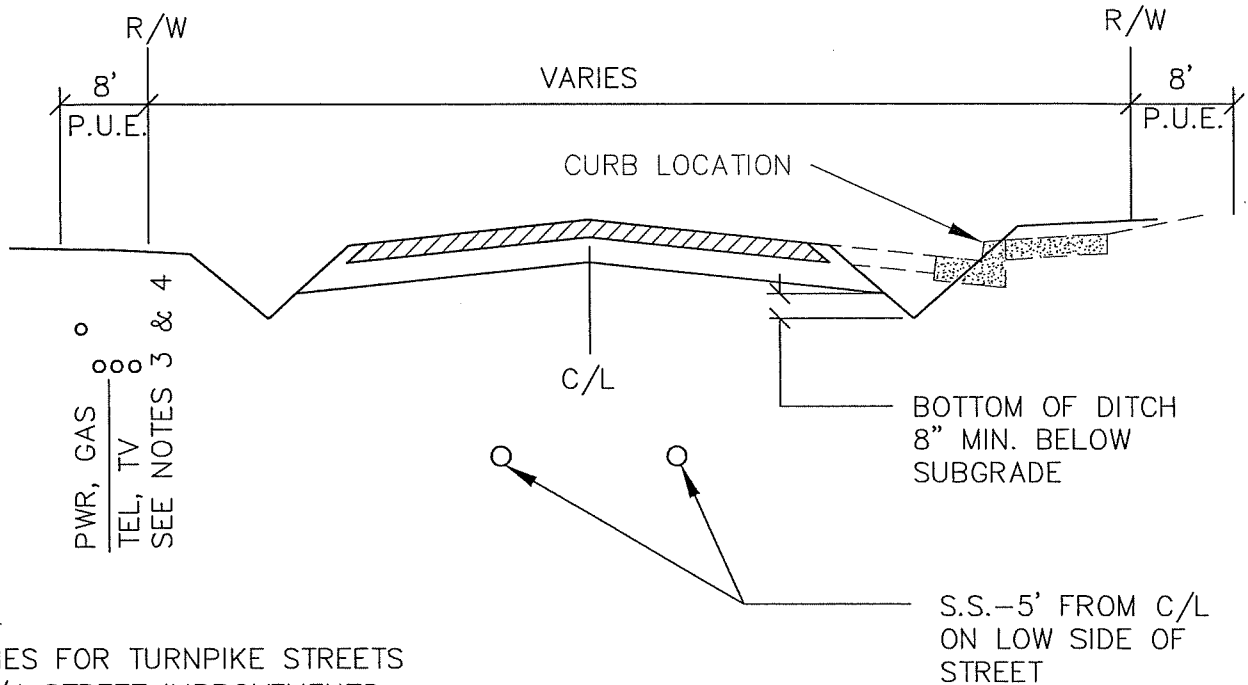

NOTE:

UTILITIES FOR TURNPIKE STREETS OR 3/4 STREET IMPROVEMENTS SHALL BE LOCATED TO ALLOW FUTURE CONSTRUCTION OF CURBED STREETS WITHOUT RELOCATING UTILITIES. SEE DETAIL 101.

TURNPIKE STREETS

NTS

NOTES:

1. 6' MIN COVER REQUIRED FOR SANITARY SEWER MAINS (4' MIN. COVER TYPICALLY REQUIRED FOR LATERALS).
2. LATERALS AND P/L CLEANOUTS TO BE INSTALLED DURING CONSTRUCTION OF SANITARY SEWER & STORM MAINS (TO AVOID FUTURE STREET CUTS).
3. WATER TO BE INSTALLED 3' BEHIND FACE OF CURB ON IMPROVED SIDE OR 3' BEHIND FUTURE FACE OF CURB LOCATION AS DIRECTED BY THE CITY ENGINEER. 10' MINIMUM SEPARATION TYPICAL BETWEEN PARALLEL WATER & SEWER MAINS.
4. MAINTAIN MIN. 5' HORIZ. SEPARATION BETWEEN PUBLIC UTILITIES & PARALLEL PRIVATE UTILITIES. OTHER VERTICAL AND HORIZONTAL SEPARATION DISTANCES SHALL BE AS SPECIFIED BY DEQ, ODWP, OR OTHER PUBLIC/PRIVATE UTILITY COMPANIES.
5. UNITY TRENCH PER FRANCHISE UTILITY COMPANY REQUIREMENTS, GENERALLY ON OPPOSITE SITE OF STREET FROM WATER LINE WHERE FEASIBLE.

LAST REVISION DATE: AUG 2022	COPYRIGHT 1996 WESTECH ENGINEERING, INC.
TYP. UTILITY LOCATIONS (TURNPIKE AND 3/4 STREETS)	
(NTS)	
AUMSVILLE, OR	DETAIL NO. 102

NOTE: PER ORS 92.044(7), "UTILITY INFRASTRUCTURE (INCLUDING PIPELINES) MAY NOT BE PLACED WITHIN ONE FOOT OF A SURVEY MONUMENT LOCATION NOTED ON A SUBDIVISION OR PARTITION PLAT."

SLOPE PAVEMENT AWAY FROM MONUMENT BOX EACH WAY WHERE POSSIBLE WITHOUT AFFECTING STREET PAVEMENT GRADES.

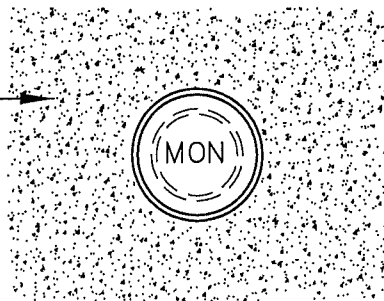

MONUMENT BOX FRAME & COVER, TYPE & SIZE AS SPECIFIED (LID NOT SHOWN THIS VIEW)

SURVEY MONUMENT WITH ALUMINUM CAP, LENGTH & PLACEMENT PER COUNTY SURVEYOR STANDARDS.

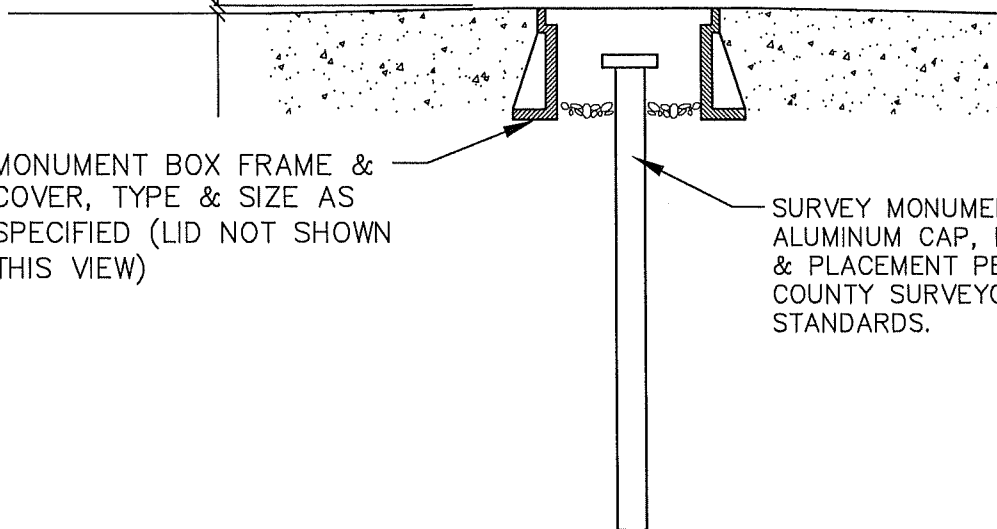

NOTES:

1. VERIFY MONUMENT BOX SIZE WITH COUNTY SURVEYOR PRIOR TO PLACEMENT. UNLESS OTHERWISE REQUIRED BY THE COUNTY SURVEYOR (BASED ON TYPE OF SURVEY MONUMENT), PROVIDE THE FOLLOWING.
 - a) USE 8" DIAMETER (MINIMUM) MONUMENT BOX FOR POSTED SPEEDS LESS THAN 35 MPH. (OLYMPIC M1014 BOX/LID, OR EJ 3614Z BOX W/3614A LID).
 - b) USE 12" DIAMETER MONUMENT BOX FOR POSTED SPEEDS EQUAL TO OR GREATER THAN 35 MPH. (EJ 3673Z BOX W/3673A LID).
2. FOR REPAVING PROJECTS, PROVIDE OVERLAY RISER RINGS FROM SAME MANUFACTURER, HEIGHT AS REQUIRED TO ACCOMODATE OVERLAY THICKNESS.

LAST REVISION DATE: FEB 2021	COPYRIGHT 1996 WESTECH ENGINEERING, INC.
SURVEY MONUMENT BOX (IN STREETS OR PUBLIC SIDEWALKS) (NTS)	
AUMSVILLE, OR	DETAIL NO. 115

C/L STREET =
C/L R/W

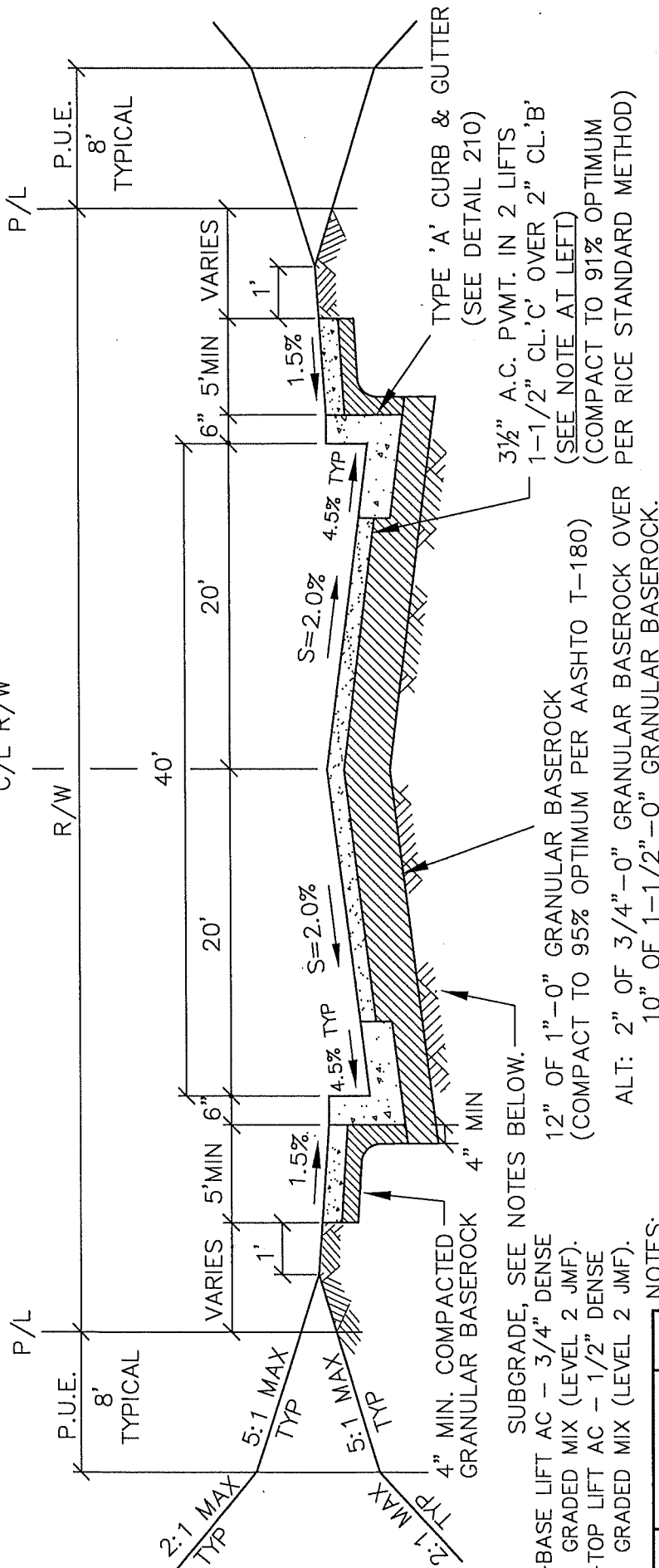

SUBGRADE, SEE NOTES BELOW.
 -BASE LIFT AC - 3/4" DENSE GRADED MIX (LEVEL 2 JMF).
 -TOP LIFT AC - 1 1/2" DENSE GRADED MIX (LEVEL 2 JMF).
 ALT: 2" OF 3/4"-0" GRANULAR BASEROCK OVER PER RICE STANDARD METHOD)
 10" OF 1-1/2"-0" GRANULAR BASEROCK.

NOTES:

1. ALL DESIGN SUBGRADES SHALL BE COMPACTED AND PROOF-ROLLED PRIOR TO PLACEMENT OF BASEROCK. COMPACTION TESTING OF SUBGRADE MAY BE WAIVED AS OUTLINED UNDER NOTE 3.
2. IF SUBGRADE FAILS THE PROOF-ROLL, SUBGRADE SHALL BE OVEREXCAVATED TO UNDISTURBED SOIL AND BACKFILLED WITH BASEROCK OVER GEOTEXTILE REINFORCEMENT FABRIC (AS SPECIFIED) TO ALLOW COMPACTION OF UPPER (DESIGN) BASEROCK SECTION AND TO MAINTAIN STRUCTURAL INTEGRITY OF NATIVE SUBGRADE SOILS. TYPICAL MIN. OVEREXCAVATION REQUIRED IS 12-INCHES. NO RUBBER TIRE EQUIPMENT ALLOWED ON SUBGRADE FOLLOWING OVEREXCAVATION.
3. IF SUBGRADE PASSES PROOF-ROLL BUT CANNOT BE COMPACTED TO 95% OPTIMUM DENSITY PER AASHTO T-180 (OR IF CONTRACTOR CHOOSES NOT TO TEST), GEOTEXTILE SEPARATION FABRIC (AS SPECIFIED) SHALL BE PLACED ON THE SUBGRADE PRIOR TO PLACEMENT OF THE BASEROCK.
4. REINFORCEMENT FABRIC (FOR USE W/OVEREXCAVATION): NON-WOVEN (MIRAFI 1000N, GEOTEX 1001, LINQ 250EX OR EQUAL), WOVEN (MIRAFI 550X, GEOTEX 250ST, LINQ GTF250 OR EQUAL).
 SEPARATION FABRIC: NON-WOVEN (MIRAFI 160N, GEOTEX 601, LINQ 150EX OR EQUAL), WOVEN (MIRAFI 500X, GEOTEX 200ST, LINQ GTF200 OR EQUAL).

LAST REVISION DATE: JULY 2021	COPYRIGHT 1996 WESTECH ENGINEERING, INC.
40' RESIDENTIAL CUL-DE-SAC (400' MAX) MINIMUM SECTION (NTS)	
AUMSVILLE, OR	DETAIL NO. 201

C/L STREET =
C/L R/W

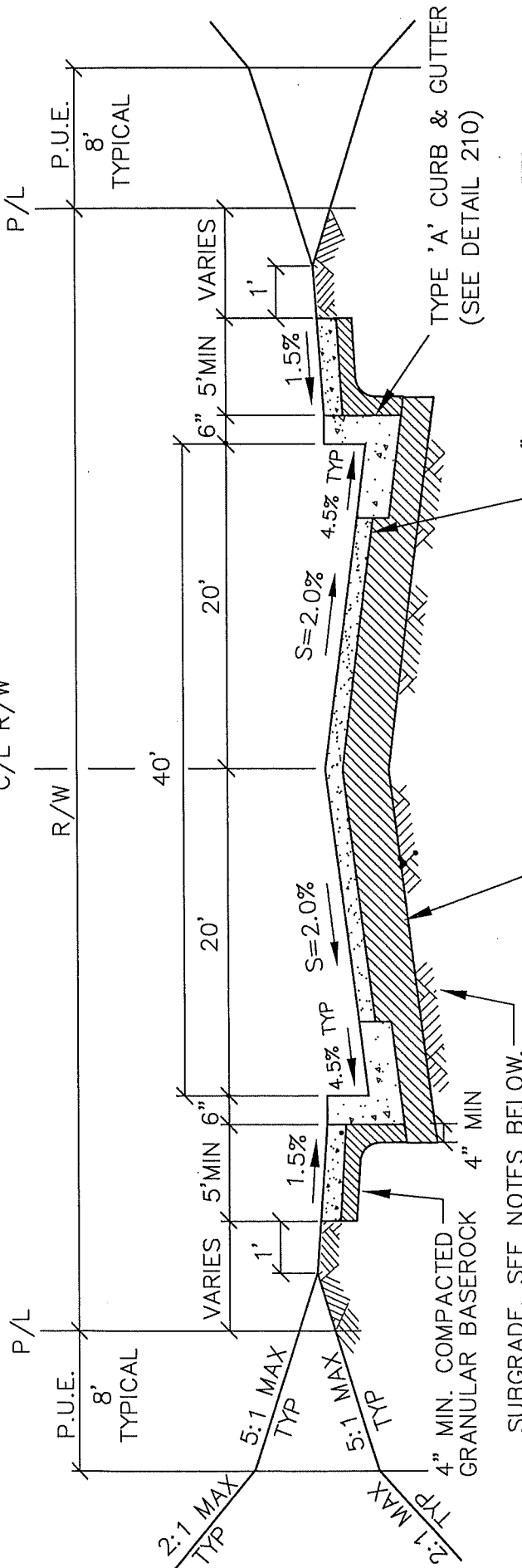

TYPE 'A' CURB & GUTTER
(SEE DETAIL 210)

4" A.C. PVMT. IN 2 LIFTS
2" CL.'C' OVER 2" CL.'B'
(SEE NOTE AT LEFT)
(COMPACT TO 91% OPTIMUM
PER RICE STANDARD METHOD)

SUBGRADE, SEE NOTES BELOW.

12" OF 1"-0" GRANULAR BASEROCK
(COMPACT TO 95% OPTIMUM PER AASHTO T-180)

ALT: 2" OF 3/4"-0" GRANULAR BASEROCK OVER
10" OF 1-1/2"-0" GRANULAR BASEROCK.

NOTES:

1. ALL DESIGN SUBGRADES SHALL BE COMPACTED AND PROOF-ROLLED PRIOR TO PLACEMENT OF BASEROCK. COMPACTION TESTING OF SUBGRADE MAY BE WAIVED AS OUTLINED UNDER NOTE 3.
2. IF SUBGRADE FAILS THE PROOF-ROLL, SUBGRADE SHALL BE OVEREXCAVATED TO UNDISTURBED SOIL AND BACKFILLED WITH BASEROCK OVER GEOTEXTILE REINFORCEMENT FABRIC (AS SPECIFIED) TO ALLOW COMPACTION OF UPPER (DESIGN) BASEROCK SECTION AND TO MAINTAIN STRUCTURAL INTEGRITY OF NATIVE SUBGRADE SOILS. TYPICAL MIN. OVEREXCAVATION REQUIRED IS 12-INCHES. NO RUBBER Tired EQUIPMENT ALLOWED ON SUBGRADE FOLLOWING OVEREXCAVATION.
3. IF SUBGRADE PASSES PROOF-ROLL BUT CANNOT BE COMPACTED TO 95% OPTIMUM DENSITY PER AASHTO T-180 (OR IF CONTRACTOR CHOOSES NOT TO TEST), GEOTEXTILE SEPARATION FABRIC (AS SPECIFIED) SHALL BE PLACED ON THE SUBGRADE PRIOR TO PLACEMENT OF THE BASEROCK.
4. REINFORCEMENT FABRIC (FOR USE W/OVEREXCAVATION): NON-WOVEN (MIRAFI 1000N, GEOTEX 1001, LINQ 250EX OR EQUAL), WOVEN (MIRAFI 550X, GEOTEX 250ST, LINQ GTF250 OR EQUAL). SEPARATION FABRIC: NON-WOVEN (MIRAFI 160N, GEOTEX 601, LINQ 150EX OR EQUAL), WOVEN (MIRAFI 500X, GEOTEX 200ST, LINQ GTF200 OR EQUAL).

LAST REVISION DATE: JULY 2021		COPYRIGHT 1996 WESTECH ENGINEERING, INC.	
40' COLLECTOR STREET 40' COMMERCIAL STREET MINIMUM SECTION (NTS)			
AUMSVILLE, OR		DETAIL NO. 202	

C/L STREET =
C/L R/W

TC RIGHT --- = TC LEFT
TC RIGHT - - - = CROWN

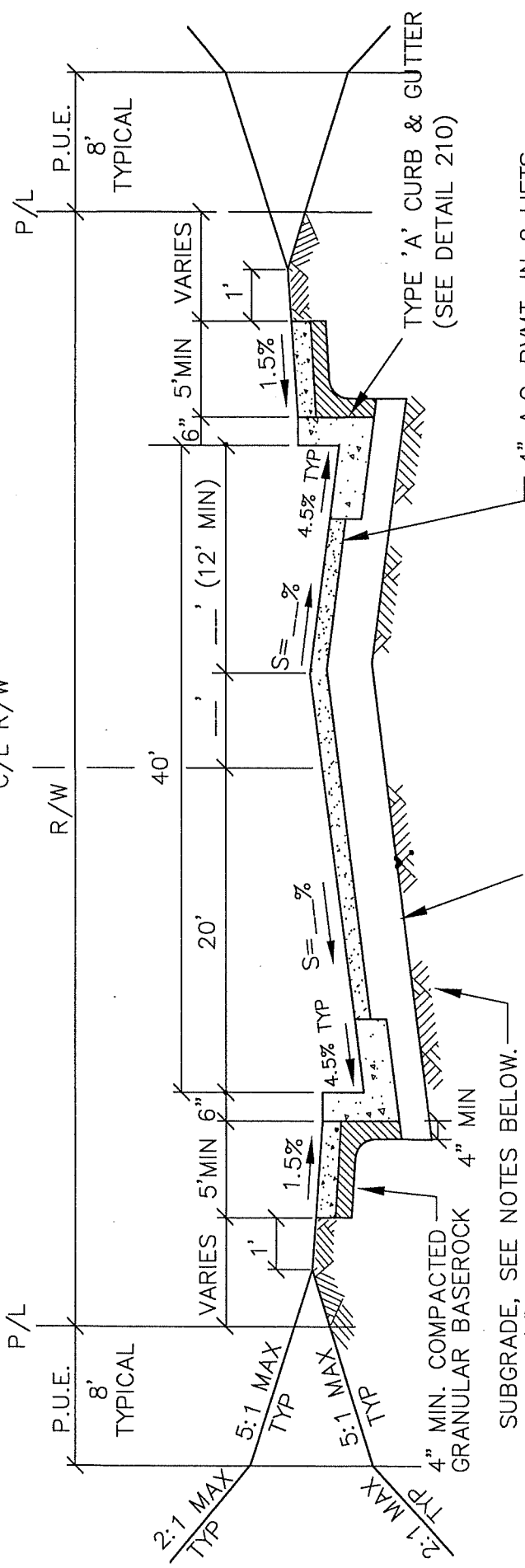

TYPE 'A' CURB & GUTTER
(SEE DETAIL 210)

4" A.C. PVMT. IN 2 LIFTS
2" CL.C' OVER 2" CL.B'
(SEE NOTE AT LEFT)

(COMPACT TO 91% OPTIMUM PER
RICE STANDARD METHOD)

4" MIN. COMPACTED
GRANULAR BASEROCK

2" OF 3/4"-0" GRANULAR BASEROCK OVER
10" OF 1-1/2"-0" GRANULAR BASEROCK.

12" OF 1"-0" GRANULAR BASEROCK
(COMPACT TO 95% OPTIMUM PER AASHTO T-180)

ALT: 2" OF 3/4"-0" GRANULAR BASEROCK OVER
10" OF 1-1/2"-0" GRANULAR BASEROCK.

- NOTES:
1. ALL DESIGN SUBGRADES SHALL BE COMPACTED AND PROOF-ROLLED PRIOR TO PLACEMENT OF BASEROCK. COMPACTION TESTING OF SUBGRADE MAY BE WAIVED AS OUTLINED UNDER NOTE 3.
 2. IF SUBGRADE FAILS THE PROOF-ROLL, SUBGRADE SHALL BE OVEREXCAVATED TO UNDISTURBED SOIL AND BACKFILLED WITH BASEROCK OVER GEOTEXTILE REINFORCEMENT FABRIC (AS SPECIFIED) TO ALLOW COMPACTION OF UPPER (DESIGN) BASEROCK SECTION AND TO MAINTAIN STRUCTURAL INTEGRITY OF NATIVE SUBGRADE SOILS. TYPICAL MIN. OVEREXCAVATION REQUIRED IS 12-INCHES. NO RUBBER Tired EQUIPMENT ALLOWED ON SUBGRADE FOLLOWING OVEREXCAVATION.
 3. IF SUBGRADE PASSES PROOF-ROLL BUT CANNOT BE COMPACTED TO 95% OPTIMUM DENSITY PER AASHTO T-180 (OR IF CONTRACTOR CHOOSES NOT TO TEST), GEOTEXTILE SEPARATION FABRIC (AS SPECIFIED) SHALL BE PLACED ON THE SUBGRADE PRIOR TO PLACEMENT OF THE BASEROCK.
 4. REINFORCEMENT FABRIC (FOR USE W/OVEREXCAVATION): NON-WOVEN (MIRAFI 1000N, GEOTEX 1001, LINQ 250EX OR EQUAL), WOVEN (MIRAFI 550X, GEOTEX 250ST, LINQ GTF250 OR EQUAL). SEPARATION FABRIC: NON-WOVEN (MIRAFI 160N, GEOTEX 601, LINQ 150EX OR EQUAL), WOVEN (MIRAFI 500X, GEOTEX 200ST, LINQ GTF200 OR EQUAL).

LAST REVISION DATE: JULY 2021	COPYRIGHT 1996 WESTECH ENGINEERING, INC.
40' COLLECTOR STREET OFFSET CROWN MINIMUM SECTION (NTS)	
AUMSVILLE, OR	DETAIL NO. 202-1

C/L STREET =
C/L R/W

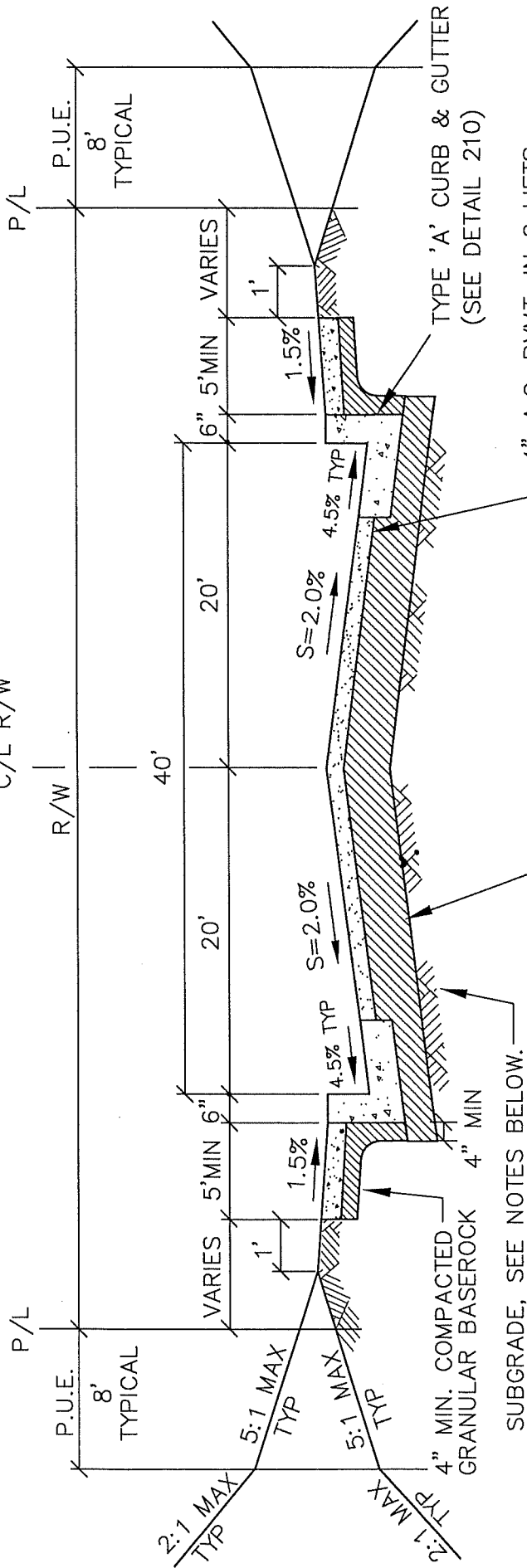

SUBGRADE, SEE NOTES BELOW.
 -BASE LIFT AC - 3/4" DENSE GRADED MIX (LEVEL 3 JMF).
 -TOP LIFT AC - 1/2" DENSE GRADED MIX (LEVEL 3 JMF).
 ALT: 2" OF 3/4"-0" GRANULAR BASEROCK OVER 13" OF 1-1/2"-0" GRANULAR BASEROCK.

- NOTES:
1. ALL DESIGN SUBGRADES SHALL BE COMPACTED AND PROOF-ROLLED PRIOR TO PLACEMENT OF BASEROCK. COMPACTION TESTING OF SUBGRADE MAY BE WAIVED AS OUTLINED UNDER NOTE 3.
 2. IF SUBGRADE FAILS THE PROOF-ROLL, SUBGRADE SHALL BE OVEREXCAVATED TO UNDISTURBED SOIL AND BACKFILLED WITH BASEROCK OVER GEOTEXTILE REINFORCEMENT FABRIC (AS SPECIFIED) TO ALLOW COMPACTION OF UPPER (DESIGN) BASEROCK SECTION AND TO MAINTAIN STRUCTURAL INTEGRITY OF NATIVE SUBGRADE SOILS. TYPICAL MIN. OVEREXCAVATION REQUIRED IS 12-INCHES. NO RUBBER Tired EQUIPMENT ALLOWED ON SUBGRADE FOLLOWING OVEREXCAVATION.
 3. IF SUBGRADE PASSES PROOF-ROLL BUT CANNOT BE COMPACTED TO 95% OPTIMUM DENSITY PER AASHTO T-180 (OR IF CONTRACTOR CHOOSES NOT TO TEST), GEOTEXTILE SEPARATION FABRIC (AS SPECIFIED) SHALL BE PLACED ON THE SUBGRADE PRIOR TO PLACEMENT OF THE BASEROCK.
 4. REINFORCEMENT FABRIC (FOR USE W/OVEREXCAVATION): NON-WOVEN (MIRAFI 1000N, GEOTEX 1001, LINQ 250EX OR EQUAL), WOVEN (MIRAFI 550X, GEOTEX 250ST, LINQ GTF250 OR EQUAL). SEPARATION FABRIC: NON-WOVEN (MIRAFI 160N, GEOTEX 601, LINQ 150EX OR EQUAL), WOVEN (MIRAFI 500X, GEOTEX 200ST, LINQ GTF200 OR EQUAL).

LAST REVISION DATE: JULY 2021		COPYRIGHT 1996 WESTECH ENGINEERING, INC.	
40' INDUSTRIAL STREET			
MINIMUM SECTION			
(NTS)			
AUMSVILLE, OR		DETAIL NO. 203	

C/L STREET =
C/L R/W

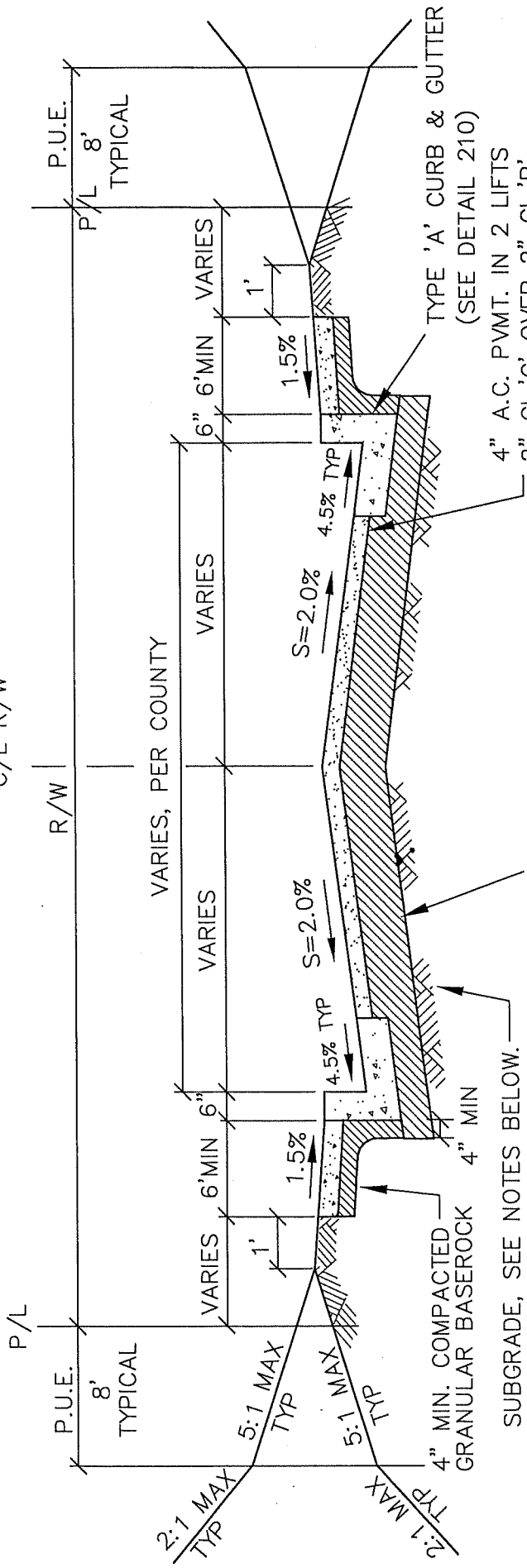

TYPE 'A' CURB & GUTTER
(SEE DETAIL 210)

4" A.C. PVMT. IN 2 LIFTS
2" CL.'C' OVER 2" CL.'B'

(SEE NOTE AT LEFT)

(COMPACT TO 91% OPTIMUM PER RICE STANDARD METHOD)

(THICKER IF REQUIRED BY ODOT)

SUBGRADE, SEE NOTES BELOW.

15" OF 1"-0" GRANULAR BASEROCK
(COMPACT TO 95% OPTIMUM PER AASHTO T-180)

ALT: 2" OF 3/4"-0" GRANULAR BASEROCK OVER
13" OF 1-1/2"-0" GRANULAR BASEROCK.

NOTES:

1. ALL DESIGN SUBGRADES SHALL BE COMPACTED AND PROOF-ROLLED PRIOR TO PLACEMENT OF BASEROCK. COMPACTION TESTING OF SUBGRADE MAY BE WAIVED AS OUTLINED UNDER NOTE 3.
2. IF SUBGRADE FAILS THE PROOF-ROLL, SUBGRADE SHALL BE OVEREXCAVATED TO UNDISTURBED SOIL AND BACKFILLED WITH BASEROCK OVER GEOTEXTILE REINFORCEMENT FABRIC (AS SPECIFIED) TO ALLOW COMPACTION OF UPPER (DESIGN) BASEROCK SECTION AND TO MAINTAIN STRUCTURAL INTEGRITY OF NATIVE SUBGRADE SOILS. TYPICAL MIN. OVEREXCAVATION REQUIRED IS 12-INCHES. NO RUBBER Tired EQUIPMENT ALLOWED ON SUBGRADE FOLLOWING OVEREXCAVATION.
3. IF SUBGRADE PASSES PROOF-ROLL BUT CANNOT BE COMPACTED TO 95% OPTIMUM DENSITY PER AASHTO T-180 (OR IF CONTRACTOR CHOOSES NOT TO TEST), GEOTEXTILE SEPARATION FABRIC (AS SPECIFIED) SHALL BE PLACED ON THE SUBGRADE PRIOR TO PLACEMENT OF THE BASEROCK.
4. REINFORCEMENT FABRIC (FOR USE W/OVEREXCAVATION): NON-WOVEN (MIRAFI 1000N, GEOTEX 1001, LINQ 250EX OR EQUAL), WOVEN (MIRAFI 550X, GEOTEX 250ST, LINQ GTF250 OR EQUAL). SEPARATION FABRIC: NON-WOVEN (MIRAFI 160N, GEOTEX 601, LINQ 150EX OR EQUAL), WOVEN (MIRAFI 500X, GEOTEX 200ST, LINQ GTF200 OR EQUAL).

LAST REVISION DATE: JULY 2021		COPYRIGHT 1996 WESTECH ENGINEERING, INC.	
ARTERIAL STREET MINIMUM SECTION			
(NTS)		DETAIL NO.	
AUMSVILLE, OR		204	

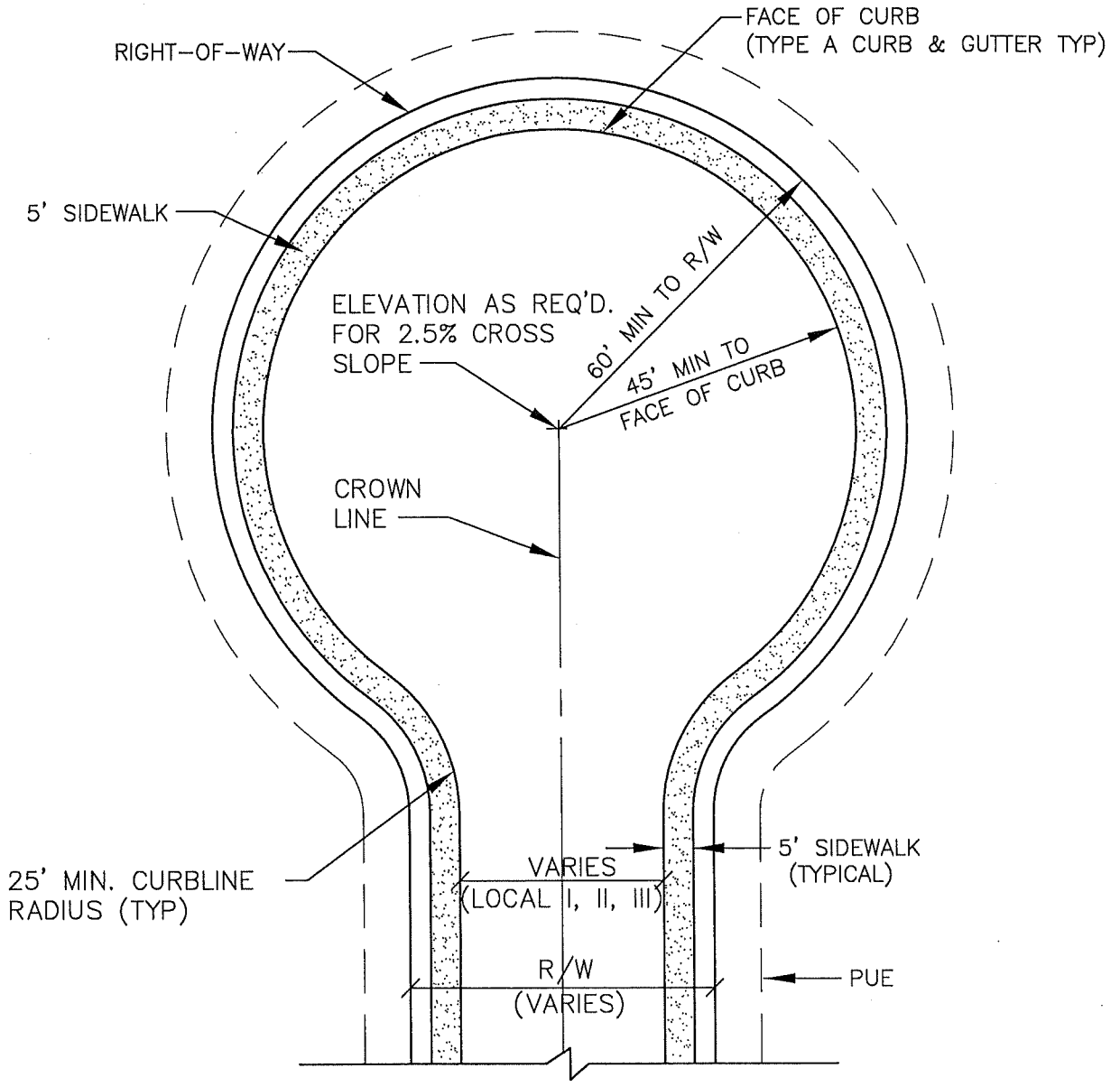

NOTES:

1. 2.5% MIN. CROSS SLOPE REQUIRED FROM CENTER OF BULB TO GUTTER.
2. MAINTAIN CROWN LINE TO CENTER OF CUL-DE-SAC BULB.

LAST REVISION DATE: JULY 2021	COPYRIGHT 1996 WESTECH ENGINEERING, INC.
STANDARD CUL-DE-SAC (RESIDENTIAL)	
(NTS)	
AUMSVILLE, OR	DETAIL NO. 205

ELEVATION AS REQ'D.
FOR 2.5% CROSS SLOPE

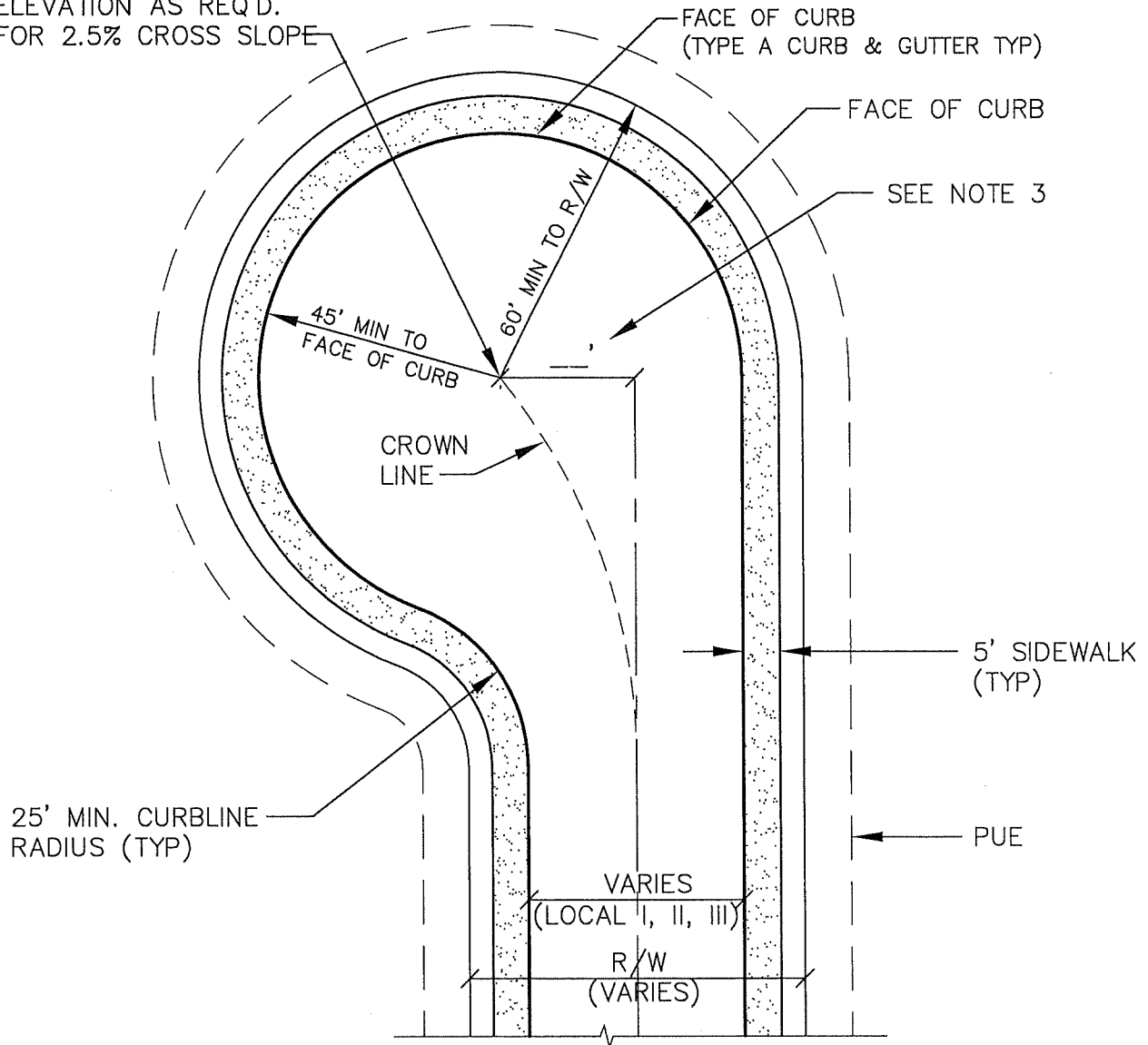

NOTES:

1. 2.5% MIN. CROSS SLOPE REQUIRED FROM CENTER OF BULB TO GUTTER.
2. MAINTAIN CROWN LINE TO CENTER OF CUL-DE-SAC BULB.
3. OFFSET FROM ROADWAY CENTERLINE TO CENTER OF BULB = CURB RADIUS MINUS ONE-HALF STREET WIDTH.

LAST REVISION DATE: JULY 2021	COPYRIGHT 1996 WESTECH ENGINEERING, INC.
OFFSET CUL-DE-SAC (RESIDENTIAL) (NTS)	
AUMSVILLE, OR	DETAIL NO. 206

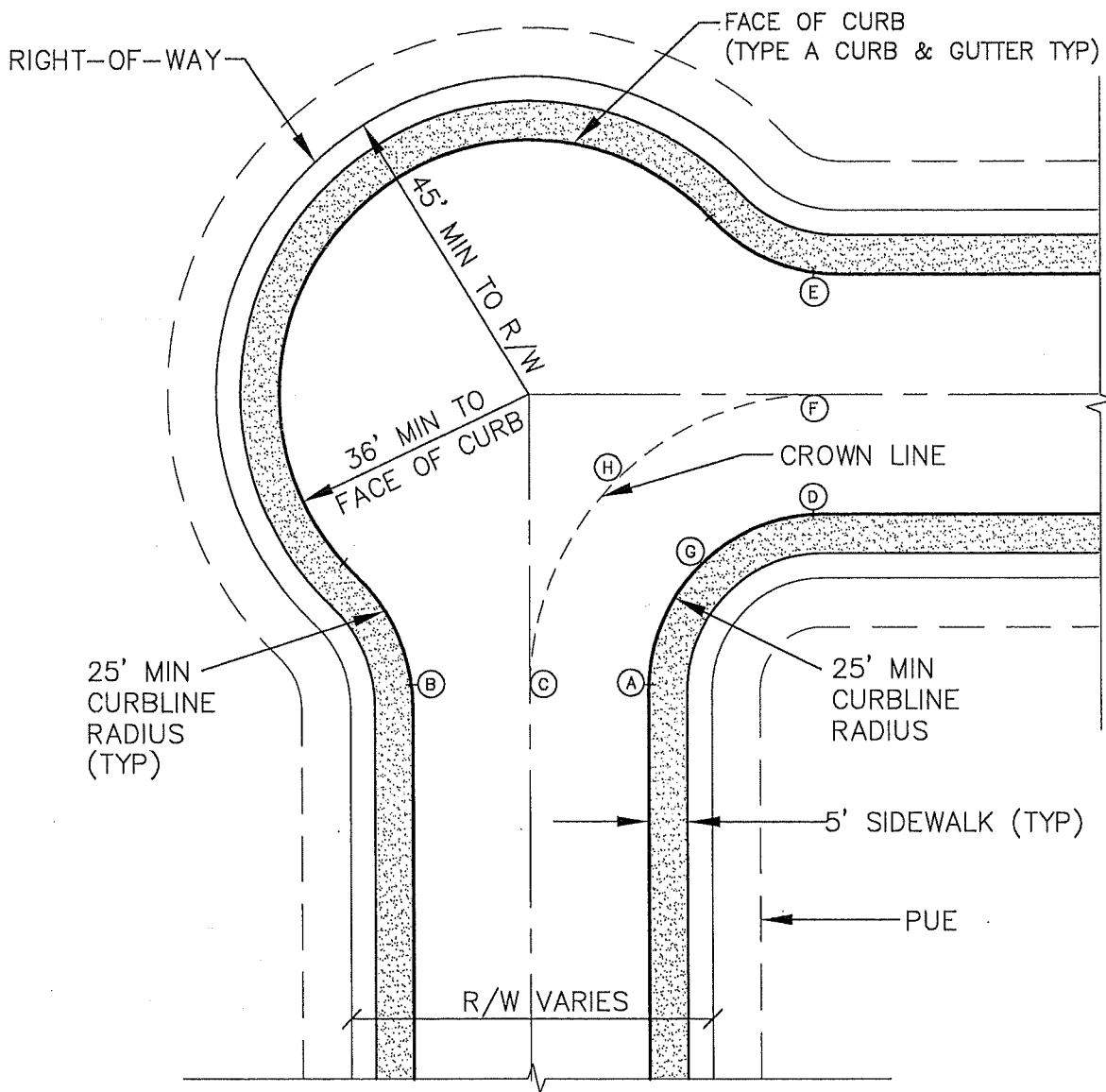

NOTES:

1. TOP CURB @ A = TOP CURB @ B = CROWN @ C
2. TOP CURB @ D = TOP CURB @ E = CROWN @ F
3. MIN. GUTTER SLOPE FROM E TO B = 0.75%
4. SET CROWN @ H 0.25' MIN. ABOVE TOP CURB @ G (4% MIN. CROSS SLOPE FROM H TO G)

LAST REVISION DATE: FEB 2021	COPYRIGHT 1996 WESTECH ENGINEERING, INC.
EYEBROW CUL-DE-SAC (RESIDENTIAL) (NTS)	
AUMSVILLE, OR	DETAIL NO. 207

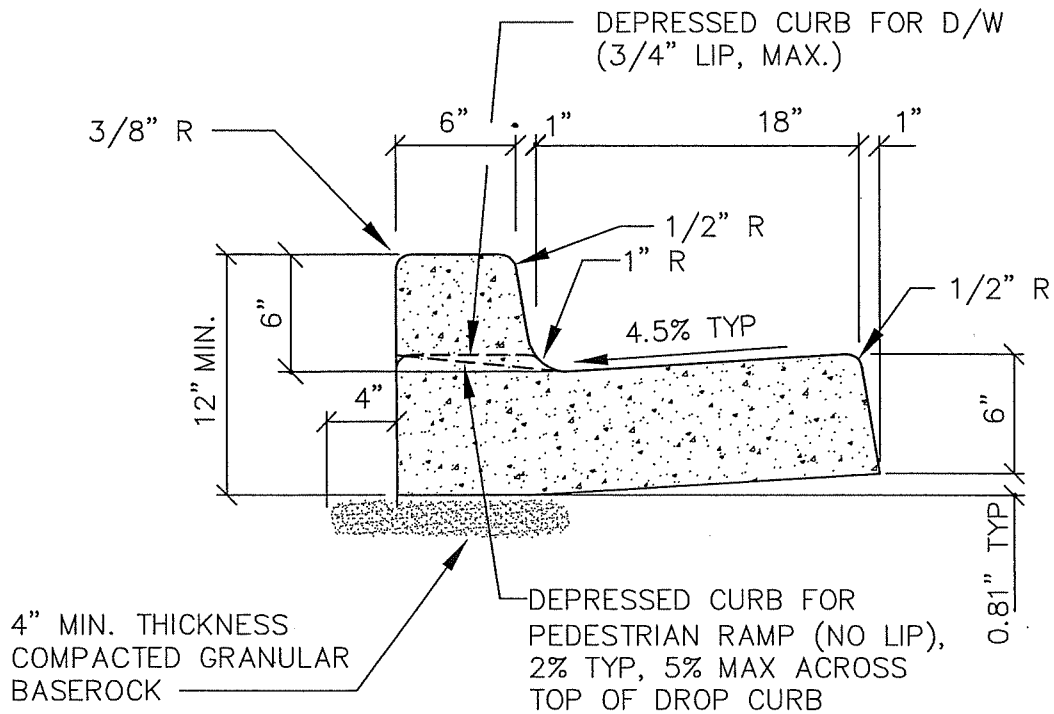

TYPE A CURB & GUTTER

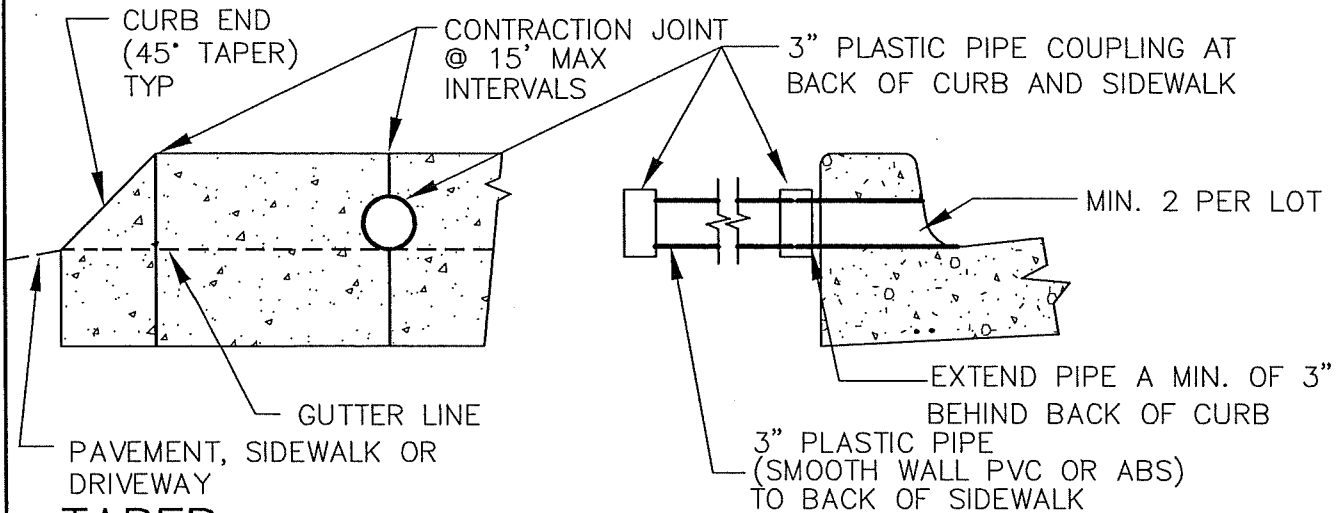

TAPER

WEEP HOLE THROUGH CURB

NOTES:

1. CONTRACTION JOINTS SHALL BE PLACED AT 15' MIN. INTERVALS AND SHALL EXTEND AT LEAST 50% THROUGH THE CURB OR CURB AND GUTTER.
2. A CONTRACTION JOINT SHALL BE PLACED ACROSS SIDEWALK OVER WEEP HOLE PIPE.
3. ALL CONCRETE SHALL BE 3300 PSI @ 28 DAYS, MAX 5" SLUMP, 4.5% AIR ($\pm 1.5\%$).
4. WHERE SIDEWALKS ARE TO BE CONSTRUCTED, EXTEND 3" PIPE TO BACK OF SIDEWALK LOCATION & INSTALL COUPLING AT ALL WEEPHOLE LOCATIONS.
5. INSTALL MIN. 2 WEEP HOLES ON ALL LOTS. ONE TO BE AT LOW POINT OF LOT, 5' FROM P/L. WEEPHOLES IN EXISTING CURBS SHALL BE CORE DRILLED.
6. MONOLITHIC CURB & PUBLIC SIDEWALK OR DRIVEWAY APRON PLACEMENT IS NOT PERMITTED EXCEPT PED RAMPS (IE. CURB CONCRETE, & SIDEWALK OR DRIVEWAY CONCRETE SHALL BE PLACED SEPARATELY).

LAST REVISION DATE:
DEC 2022

COPYRIGHT 1996
WESTECH ENGINEERING, INC.

TYPE 'A' CURB AND GUTTER AND WEEP HOLE

(NTS)

AUMSVILLE, OR

DETAIL NO.

210

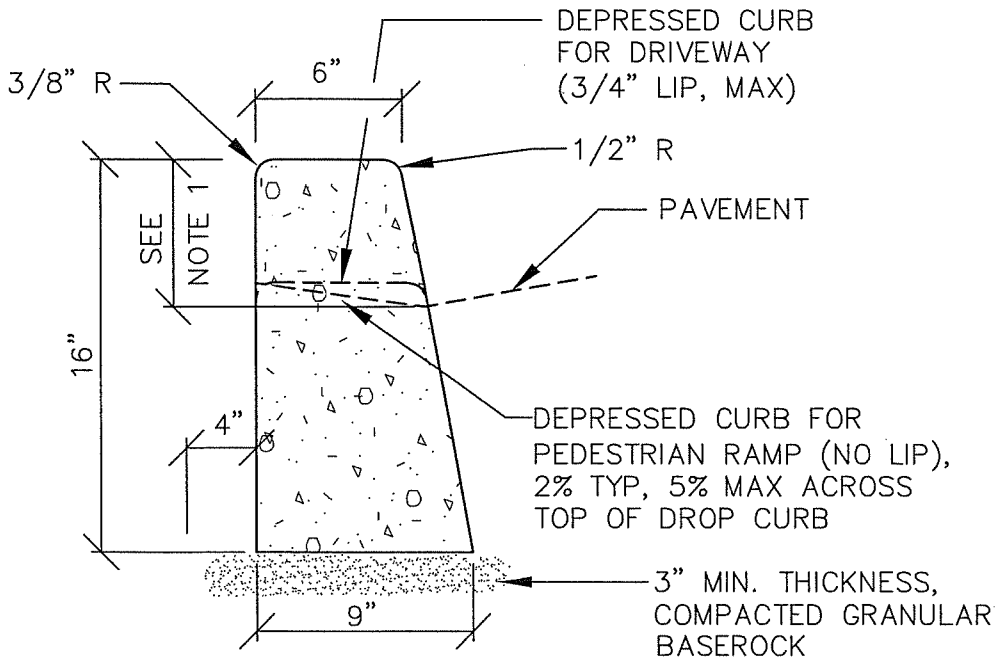

TYPE 'C' (FULL HEIGHT) CURB

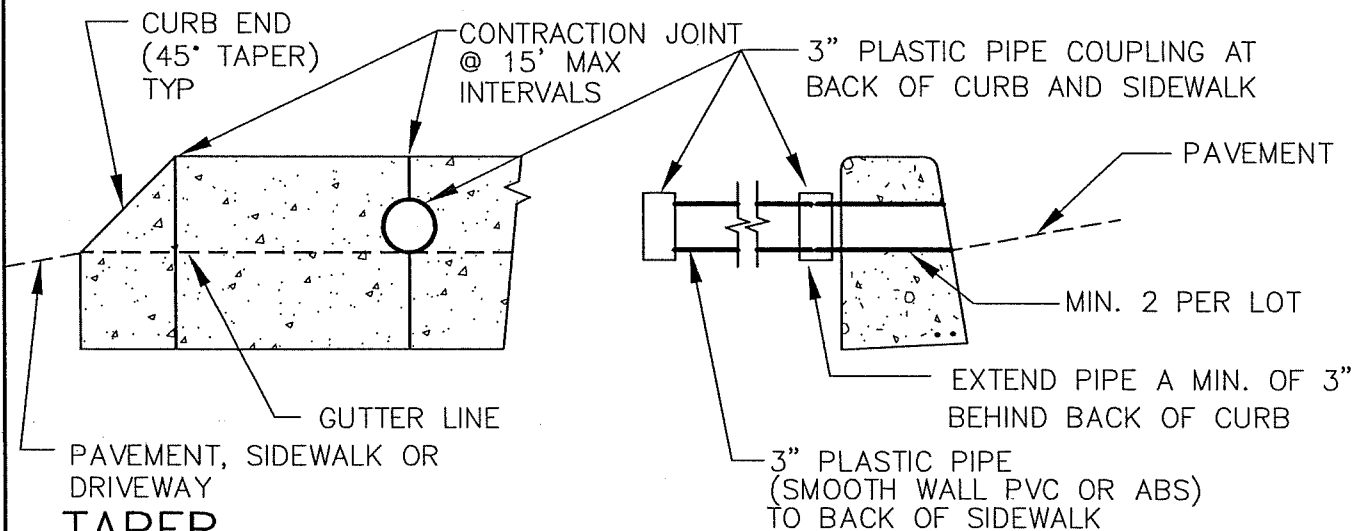

WEEP HOLE THROUGH CURB

NOTES

1. 7" CURB EXPOSURE FOR ARTERIAL & COLLECTOR STREETS TYPICAL WHERE TYPE C CURB IS ALLOWED.
2. 6" EXPOSURE ALL OTHER PUBLIC STREETS, PRIVATE STREETS & PARKING LOTS.
3. A CONTRACTION JOINT SHALL BE PLACED ACROSS SIDEWALK OVER WEEP HOLE PIPE.
4. ALL CONCRETE SHALL BE 3300 PSI @ 28 DAYS, MAX 5" SLUMP, 4.5% AIR (±1.5%).
5. WHERE SIDEWALKS ARE TO BE CONSTRUCTED, EXTEND 3" PIPE TO BACK OF SIDEWALK LOCATION & INSTALL COUPLING AT ALL WEEPHOLE LOCATIONS.
6. INSTALL MIN. 2 WEEP HOLES ON ALL LOTS. ONE TO BE AT LOW POINT OF LOT, 5' FROM P/L. WEEP HOLES IN EXISTING CURBS SHALL BE CORE DRILLED.
6. **MONOLITHIC CURB & PUBLIC SIDEWALK OR DRIVEWAY APRON PLACEMENT IS NOT PERMITTED EXCEPT PED RAMPS (IE. CURB CONCRETE & SIDEWALK OR DRIVEWAY CONCRETE SHALL BE PLACED SEPARATELY).**

LAST REVISION DATE: DEC 2022	COPYRIGHT 1996 WESTECH ENGINEERING, INC.
TYPE 'C' CURB AND WEEPHOLE	
(NTS)	
AUMSVILLE, OR	DETAIL NO. 211

TOOLED CONTRACTION JOINTS TYPICAL AT 5' INTERVALS. (**BROOM FINISH. SLICKS ON FRONT & BACK OF SIDEWALK. NO SLICKS ON CROSS JOINTS**)

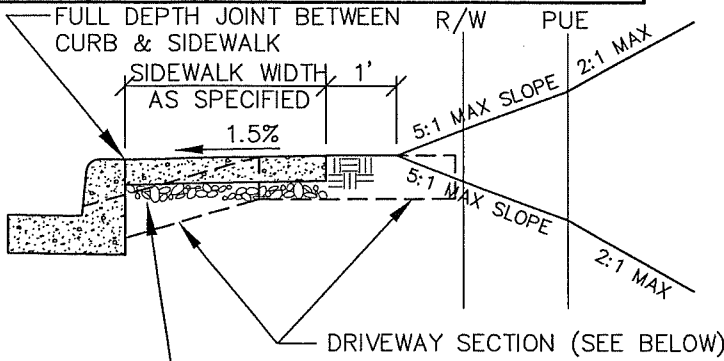

TYP. CROSS SECTION

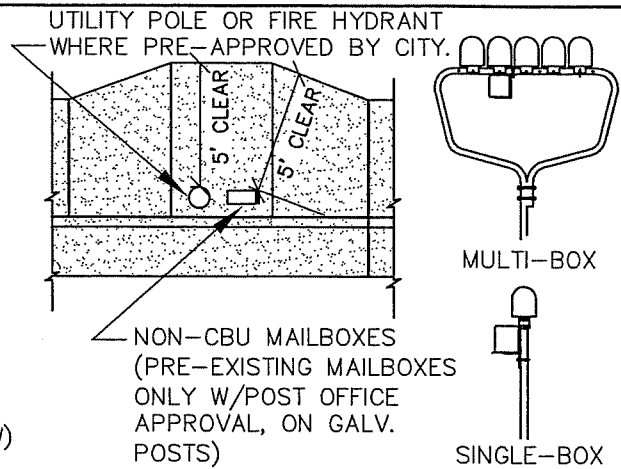

S/W AT OBSTRUCTION

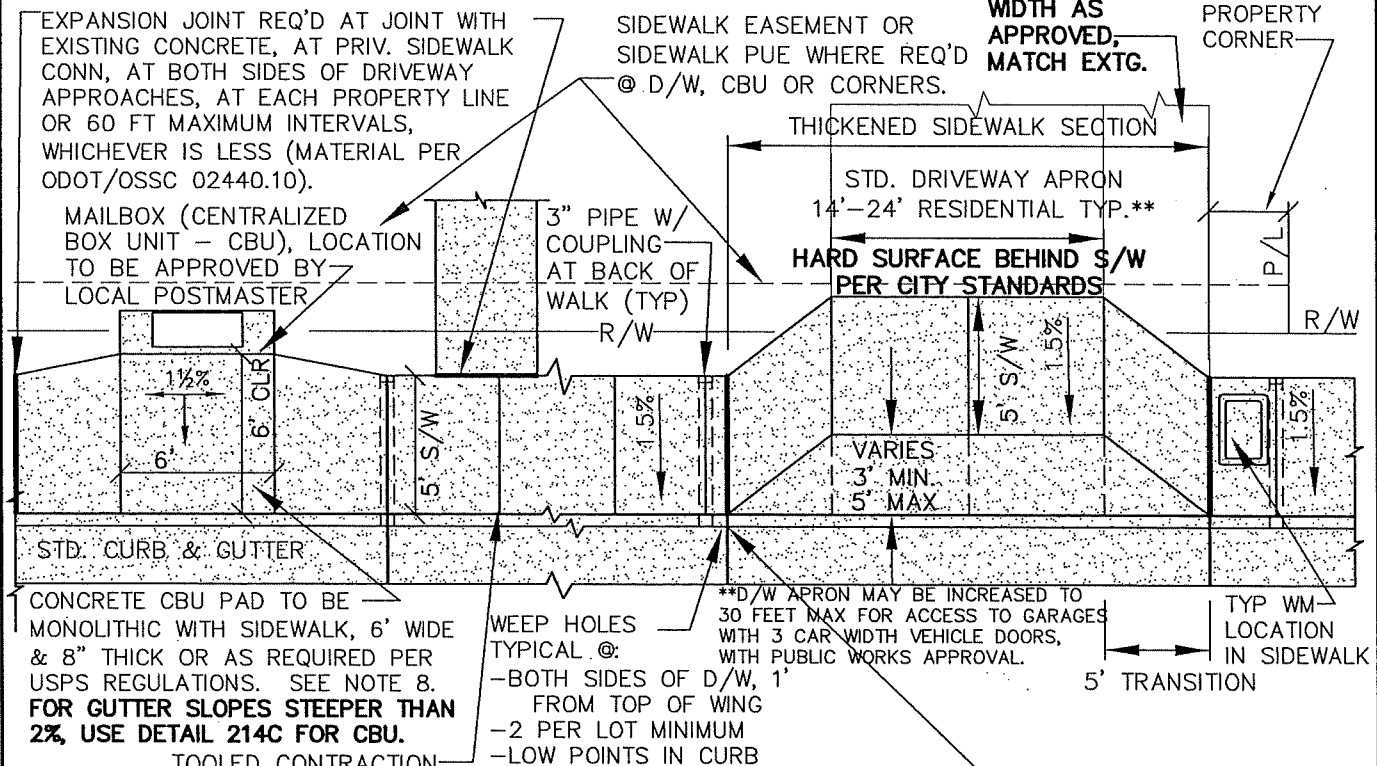

TYP. PLAN VIEW

- NOTES:**
1. MONOLITHIC PLACEMENT OF CONCRETE FOR STREET CURB & PARALLEL PUBLIC SIDEWALK IS PROHIBITED.
 2. CONCRETE THICKNESS. STANDARD SIDEWALKS SHALL BE 4" MIN. THICK. SIDEWALKS THROUGH RESIDENTIAL DRIVEWAYS (INCLUDING WINGS) SHALL BE 6" MIN. THICK. COMMERCIAL DRIVEWAYS & ALLEY APPROACHES SHALL BE 8" MIN. THICK.
 3. SIDEWALKS 8' & WIDER SHALL HAVE A LONGITUDINAL CONTRACTION JOINT AT MIDPOINT.
 4. CONCRETE SHALL BE 3300 PSI @ 28 DAYS, MAX 5" SLUMP, 4.5% AIR (±1.5%).
 5. PCC APRONS JOINTED TO MATCH SIDEWALK PATTERN.
 6. SIDEWALKS SHALL BE LOCATED ENTIRELY WITHIN PUBLIC RIGHT-OF-WAY OR SIDEWALK EASEMENTS, INCLUDING AT DRIVEWAYS & INTERSECTIONS.
 7. ADA ACCESS TO CBU MAILBOXES SHALL CONFORM W/SECT 1111 OF OSSC (OREGON STRUCTURAL SPECIALTY CODE), INCLUDING AN ADA PEDESTRIAN CURB RAMP LOCATED WITHIN 50 FEET OF THE CBU. PROWAG REQUIRED 6'x6' TURNING SPACE IN FRONT OF CBU SHALL NOT EXCEED 2% IN ANY DIRECTION. **CBU LAYOUT ABOVE ASSUMES STREET & CURB GRADE DOES NOT EXCEED 2%.**
 8. IF ADDITIONAL DRIVEWAY PARKING WIDTH IS PROPOSED BEYOND TOP OF WING, SEE NOTES ON DETAIL 213.

LAST REVISION DATE: JUNE 2022	COPYRIGHT 2021 WESTECH ENGINEERING, INC.
CURBLINE SIDEWALKS AND DRIVEWAY APRONS	
(NTS)	
AUMSVILLE, OR	DETAIL NO. 212

SEE DETAIL 212 FOR STANDARD MAILBOX LOCATION & MOUNTING DETAILS & INFORMATION.

TOOLED CONTRACTION JOINTS TYPICAL AT 5' INTERVALS. **(BROOM FINISH, SLICKS ON FRONT & BACK OF SIDEWALK, NO SLICKS ON CROSS JOINTS)**

EXPANSION JOINT REQ'D AT JOINT WITH EXISTING CONCRETE, AT PRIV. SIDEWALK CONN, AT BOTH SIDES OF DRIVEWAY APPROACHES, AT EACH PROPERTY LINE OR 60 FT MAXIMUM INTERVALS, WHICHEVER IS LESS (MATERIAL PER ODOT/OSSC 02440.10).

NOTE: CONTRACTION JOINT REQUIRED AT BOTH SIDES OF STANDARD DRIVEWAY SECTION AND OVER ROOF DRAINS

**D/W APRON MAY BE INCREASED TO 30 FEET MAX FOR ACCESS TO GARAGES WITH 3 CAR WIDTH VEHICLE DOORS, WITH PUBLIC WORKS APPROVAL.

2' MIN. OFFSET FROM PROPERTY CORNER TO TOP OF APRON WING

INSTALL BOLLARD OR LANDSCAPE W/ SHRUB (3-5 GAL MATURE) BETWEEN TAPER & BACK OF SIDEWALK (PROPERTY OWNER TO MAINTAIN @ 3' MAX HEIGHT). ALSO SEE NOTE 10.

3" PIPE WITH COUPLING AT BACK OF WALK (TYP)

HARD SURFACE BEHIND S/W PER CITY STANDARDS
ADDITIONAL PARKING WIDTH AS APPROVED, MATCH EXTG.

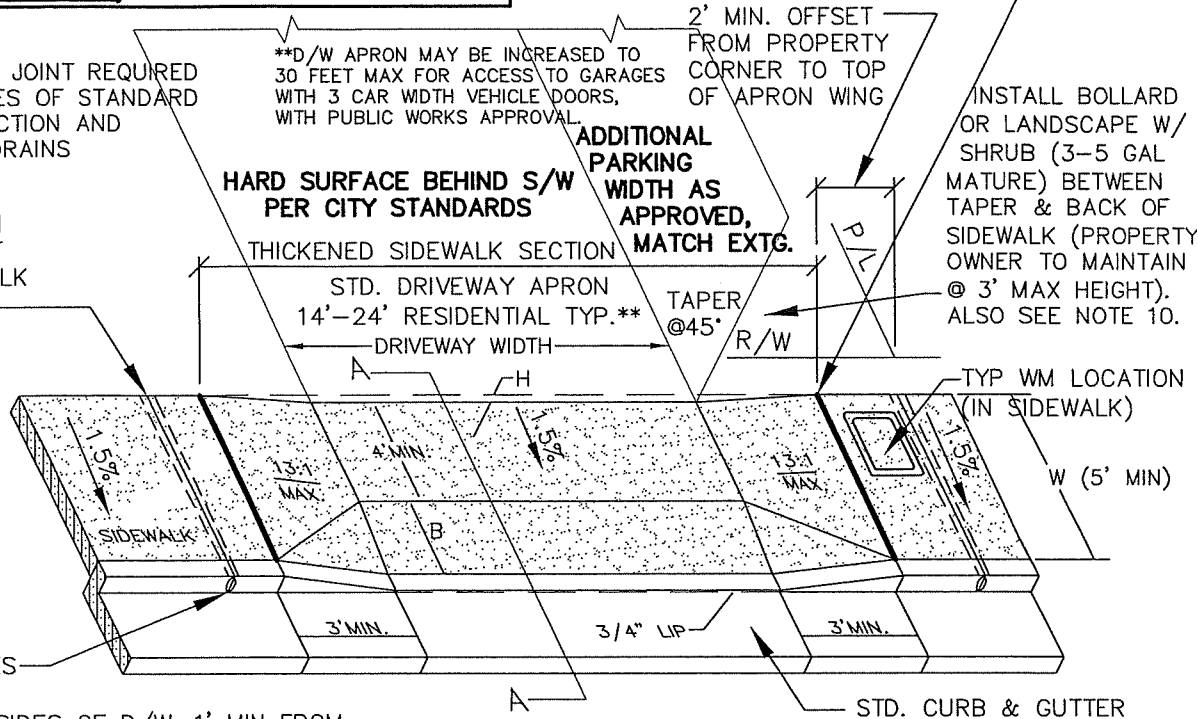

WEEP HOLES TYPICAL @:

- BOTH SIDES OF D/W, 1' MIN FROM TOP OF WING EACH SIDE
- LOW POINTS IN CURB/LOT FRONTAGE

W	B	H	
5'	1'	0.27'	(3-1/4")
6'	2'	0.23'	(2-3/4")
7'	3'	0.19'	(2-1/4")

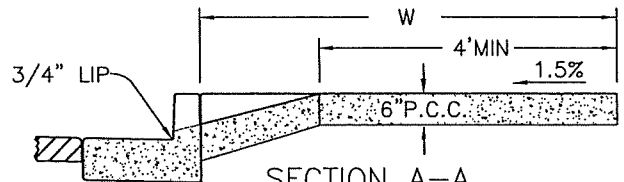

NOTES:

- SEE DETAIL 2120 & 2021 FOR STANDARD SIDEWALK DETAILS. **USE OF THIS DETAIL REQUIRES SPECIFIC APPROVAL BY PUBLIC WORKS PRIOR TO FORMING.**
- CONCRETE THICKNESS.** CONCRETE DEPTH FOR STANDARD SIDEWALKS SHALL BE 4" MIN. SF & DUPLEX RESIDENTIAL DRIVEWAY SECTIONS INCLUDING SIDEWALKS THROUGH DRIVEWAYS SHALL BE 6" MIN. THICKNESS.
- MONOLITHIC PLACEMENT OF CONCRETE FOR STREET CURB & PARALLEL PUBLIC SIDEWALK IS PROHIBITED.
- DRIVEWAY APPROACH SHOWN ON THIS DETAIL NOT ALLOWED ON LOTS WITH DRIVEWAYS BELOW CURB ELEVATION (ADVERSE GRADE) UNLESS A CATCH BASIN IS PROVIDED WITHIN 125 FEET UPHILL ALONG CURBLINE, AND DRIVEWAY IS NOT LOCATED AT STREET LOW POINT.
- CONCRETE SHALL BE 3300 PSI @ 28 DAYS, MAX 5" SLUMP, 4.5% AIR ($\pm 1.5\%$).
- PCC APRONS SHALL BE JOINTED TO MATCH SIDEWALK PATTERN.
- SIDEWALKS SHALL BE LOCATED ENTIRELY WITHIN RIGHT-OF-WAY OR SIDEWALK EASEMENTS, INCLUDING SIDEWALKS AT INTERSECTIONS.
- CROSS SLOPE IS MEASURED FROM HORIZONTAL.
- RUNNING SLOPE OF SIDEWALK AT TRANSITION DOWN TO DRIVEWAYS SHALL TYPICALLY NOT EXCEED 1V:13H (7.7%), BUT SHALL NOT REQUIRE THE LENGTH TO EXCEED 15 FEET.
- FULL DEPTH CURB (DTL 211) MAY BE USED IN PLACE OF BOLLARD, WITH WRITTEN PW DIRECTOR APPROVAL.

LAST REVISION DATE:

JUNE 2022

COPYRIGHT 2021
WESTECH ENGINEERING, INC.

**RESIDENTIAL DW APRON
CURBLINE SIDEWALK
UPHILL LOTS ONLY**

(NTS)

DETAIL NO.

212A

AUMSVILLE, OR

SEE DETAIL 212 FOR STANDARD MAILBOX LOCATION & MOUNTING DETAILS & INFORMATION.

TOOLED CONTRACTION JOINTS TYPICAL AT 5' INTERVALS. **(BROOM FINISH, SLICKS ON FRONT & BACK OF SIDEWALK, NO SLICKS ON CROSS JOINTS)**

EXPANSION JOINT REQ'D AT JOINT WITH EXISTING CONCRETE, AT PRIV. SIDEWALK CONN, AT BOTH SIDES OF DRIVEWAY APPROACHES, AT EACH PROPERTY LINE OR 60 FT MAXIMUM INTERVALS, WHICHEVER IS LESS (MATERIAL PER ODOT/OSSC 02440.10).

NOTE: CONTRACTION JOINT REQUIRED AT BOTH SIDES OF STANDARD DRIVEWAY SECTION AND OVER ROOF DRAINS

**D/W APRON MAY BE INCREASED TO 30 FEET MAX FOR ACCESS TO GARAGES WITH 3 CAR WIDTH VEHICLE DOORS, WITH PUBLIC WORKS APPROVAL.

2' MIN. OFFSET FROM PROPERTY CORNER TO TOP OF APRON WING

INSTALL BOLLARD OR LANDSCAPE W/ SHRUB (3-5 GAL MATURE) BETWEEN TAPER & BACK OF SIDEWALK (PROPERTY OWNER TO MAINTAIN @ 3' MAX HEIGHT). ALSO SEE NOTE 10.

3" PIPE AND COUPLING AT BACK OF WALK (TYP)

HARD SURFACE BEHIND S/W PER CITY STANDARDS
THICKENED SIDEWALK SECTION
STD. DRIVEWAY APRON 14'-24' RESIDENTIAL TYP.**
DRIVEWAY WIDTH

ADDITIONAL PARKING WIDTH AS APPROVED, MATCH EXTG.

TAPER @45°
R/W

TYP WM LOCATION (IN SIDEWALK)

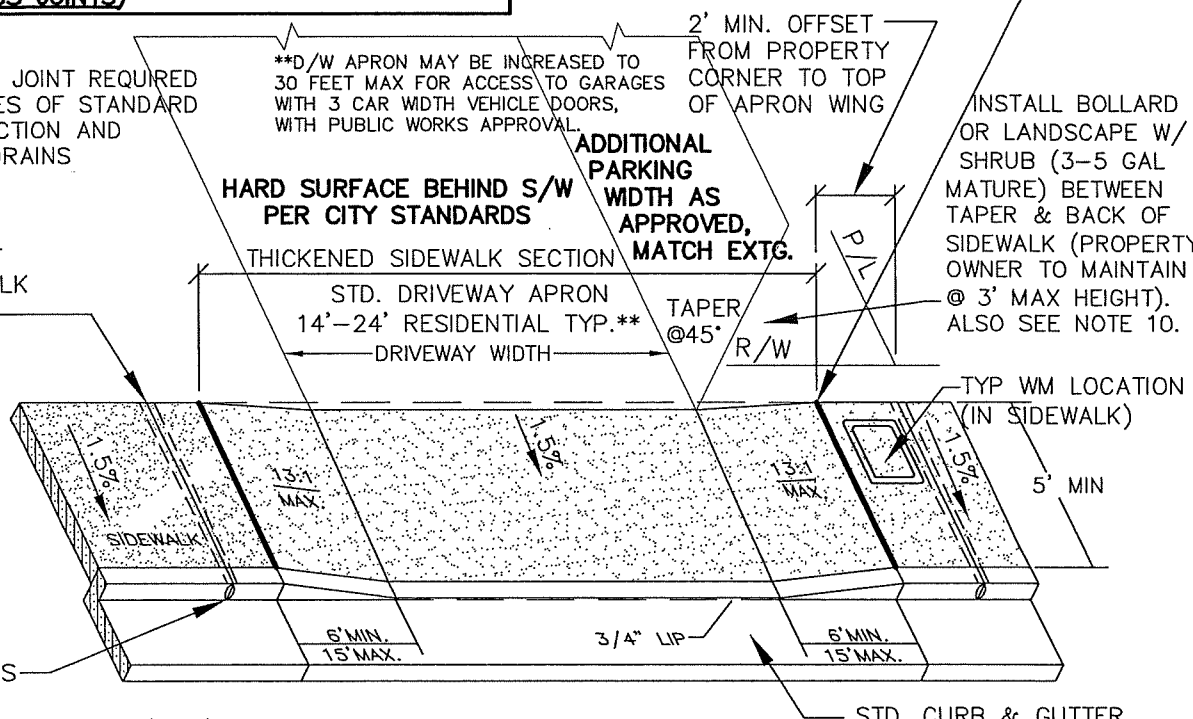

WEEP HOLES TYPICAL @:

- BOTH SIDES OF D/W, 1' MIN FROM TOP OF WING EACH SIDE
- LOW POINTS IN CURB/LOT FRONTAGE

STD. CURB & GUTTER

NOTES:

- SEE DETAIL 2120 & 2021 FOR STANDARD SIDEWALK DETAILS. **USE OF THIS DETAIL REQUIRES SPECIFIC APPROVAL BY PUBLIC WORKS PRIOR TO FORMING.**
- CONCRETE THICKNESS.** CONCRETE DEPTH FOR STANDARD SIDEWALKS SHALL BE 4" MIN. SF & DUPLEX RESIDENTIAL DRIVEWAY SECTIONS INCLUDING SIDEWALKS THROUGH DRIVEWAYS SHALL BE 6" MIN. THICKNESS.
- MONOLITHIC PLACEMENT OF CONCRETE FOR STREET CURB & PARALLEL PUBLIC SIDEWALK IS PROHIBITED.
- DRIVEWAY APPROACH SHOWN ON THIS DETAIL NOT ALLOWED ON LOTS WITH DRIVEWAYS BELOW CURB ELEVATION (ADVERSE GRADE) UNLESS A CATCH BASIN IS PROVIDED WITHIN 125 FEET UPHILL ALONG CURBLINE, AND DRIVEWAY IS NOT LOCATED AT STREET LOW POINT.
- CONCRETE SHALL BE 3300 PSI @ 28 DAYS, MAX 5" SLUMP, 4.5% AIR (±1.5%).
- PCC APRONS SHALL BE JOINTED TO MATCH SIDEWALK PATTERN.
- SIDEWALKS SHALL BE LOCATED ENTIRELY WITHIN RIGHT-OF-WAY OR SIDEWALK EASEMENTS, INCLUDING SIDEWALKS AT INTERSECTIONS.
- CROSS SLOPE IS MEASURED FROM HORIZONTAL.
- RUNNING SLOPE OF SIDEWALK AT TRANSITION DOWN TO DRIVEWAYS SHALL TYPICALLY NOT EXCEED 1V:13H (7.7%), BUT SHALL NOT REQUIRE THE LENGTH TO EXCEED 15 FEET.
- FULL DEPTH CURB (DTL 211) MAY BE USED IN PLACE OF BOLLARD, WITH WRITTEN PW DIRECTOR APPROVAL.

LAST REVISION DATE: JUNE 2022	COPYRIGHT 2021 WESTECH ENGINEERING, INC.
RESIDENTIAL DW APRON AT POSITIVE GRADE D/W'S CURBLINE SIDEWALK (NTS)	
WESTECH ENG.	DETAIL NO. 212B

TOOLED CONTRACTION JOINTS TYPICAL AT 5' INTERVALS. **(BROOM FINISH, SLICKS ON FRONT & BACK OF SIDEWALK, NO SLICKS ON CROSS JOINTS)**

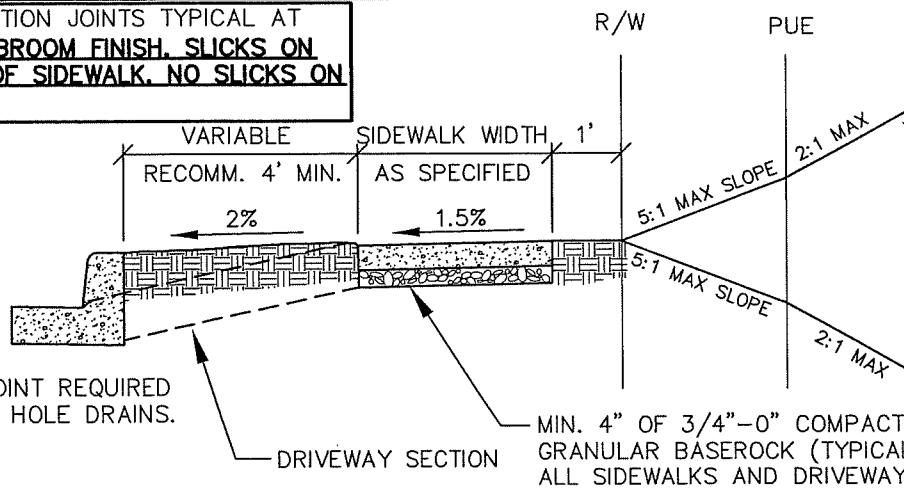

NOTE:
CONTRACTION JOINT REQUIRED OVER ALL WEEP HOLE DRAINS.

TYP. CROSS SECTION

**D/W APRON MAY BE INCREASED TO 30 FEET MAX FOR ACCESS TO GARAGES WITH 3 CAR WIDTH VEHICLE DOORS, WITH PUBLIC WORKS APPROVAL.

ADDITIONAL PARKING WIDTH AS APPROVED, MATCH EXTG.

INSTALL BOLLARD OR LANDSCAPE WITH SHRUB (3-5 GAL MATURE) BETWEEN TAPER & BACK OF S/W (PROPERTY OWNER TO MAINTAIN @ 3' MAX HEIGHT). ALSO SEE NOTE 7

EXPANSION JOINT REQ'D AT JOINT WITH EXISTING CONCRETE, AT PRIV. SIDEWALK CONN, AT BOTH SIDES OF DRIVEWAY APPROACHES, AT EACH PROPERTY LINE OR 60 FT MAXIMUM INTERVALS, WHICHEVER IS LESS (MATERIAL PER ODOT/OSSC 02440.10).

HARD SURFACE BEHIND S/W PER CITY STANDARDS

2' TYP. OFFSET FROM PROPERTY CORNER

STD. DRIVEWAY APRON 14'-24' RESIDENTIAL TYP.**

TAPER @45°

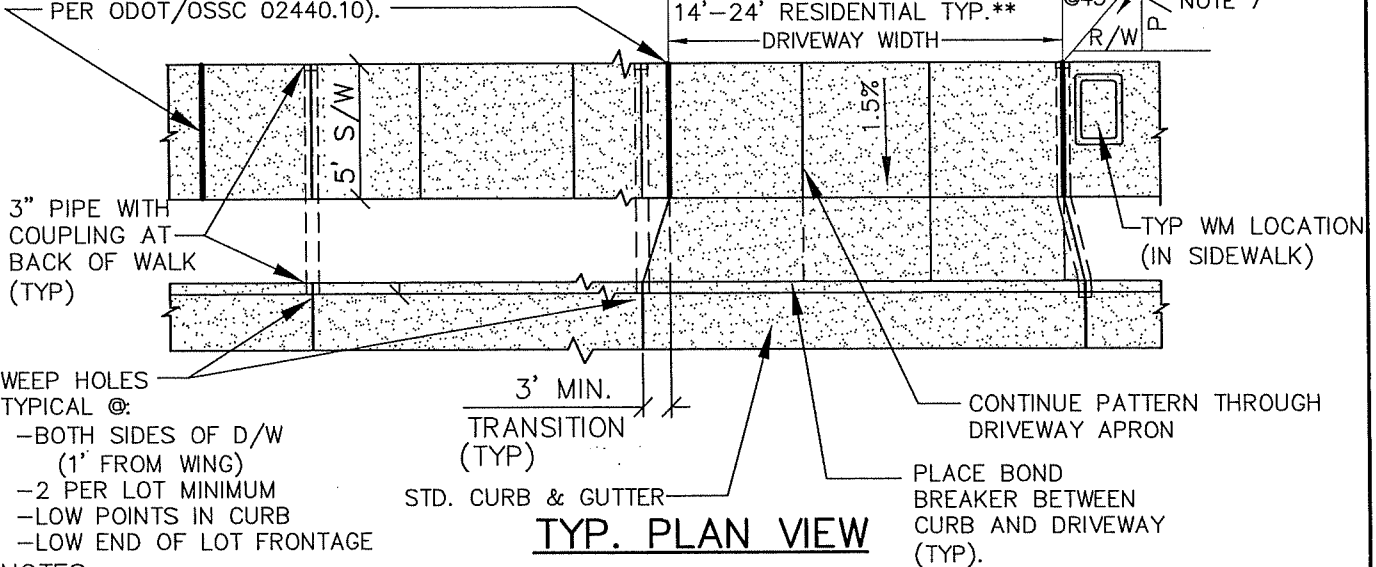

TYP. PLAN VIEW

NOTES:

1. MONOLITHIC PLACEMENT OF CONCRETE FOR STREET CURB & PARALLEL PUBLIC SIDEWALK IS PROHIBITED.
2. CONCRETE THICKNESS. STANDARD SIDEWALKS SHALL BE 4" MIN. THICK. SIDEWALKS THROUGH RESIDENTIAL DRIVEWAYS (INCLUDING WINGS) SHALL BE 6" MIN. THICK. COMMERCIAL DRIVEWAYS & ALLEY APPROACHES SHALL BE 8" MIN. THICK.
3. SIDEWALKS 10' & WIDER SHALL HAVE A LONGITUDINAL CONTRACTION JOINT 5' MAX. ON CENTER.
4. JOINT PCC APRONS TO MATCH SIDEWALK PATTERN.
5. CONCRETE SHALL BE 3300 PSI @ 28 DAYS, MAX 5" SLUMP, 4.5% AIR (±1.5%).
6. CBU MAILBOXES ON PROPERTY LINE SIDEWALKS SHALL MEET PROWAG STANDARDS, INCLUDING TURNING SPACE/LANDING FRONTING CBU (6'x6' MIN, 1½% SLOPE), LANDING APPROACH WIDTHS/SLOPES/LENGTHS, AND CONCRETE THICKNESS AS SHOWN ON DETAILS 212 & 214C, AND PEDESTRIAN CURB RAMP LOCATED WITHIN 50 FEET OF THE CBU.
7. FULL DEPTH CURB (DTL 211) MAY BE USED IN PLACE OF BOLLARD, WITH WRITTEN PW DIRECTOR APPROVAL.

LAST REVISION DATE: JUNE 2022	COPYRIGHT 1996 WESTECH ENGINEERING, INC.
PROPERTY LINE SIDEWALKS AND DRIVEWAY APRONS	
(NTS)	
AUMSVILLE, OR	DETAIL NO. 213

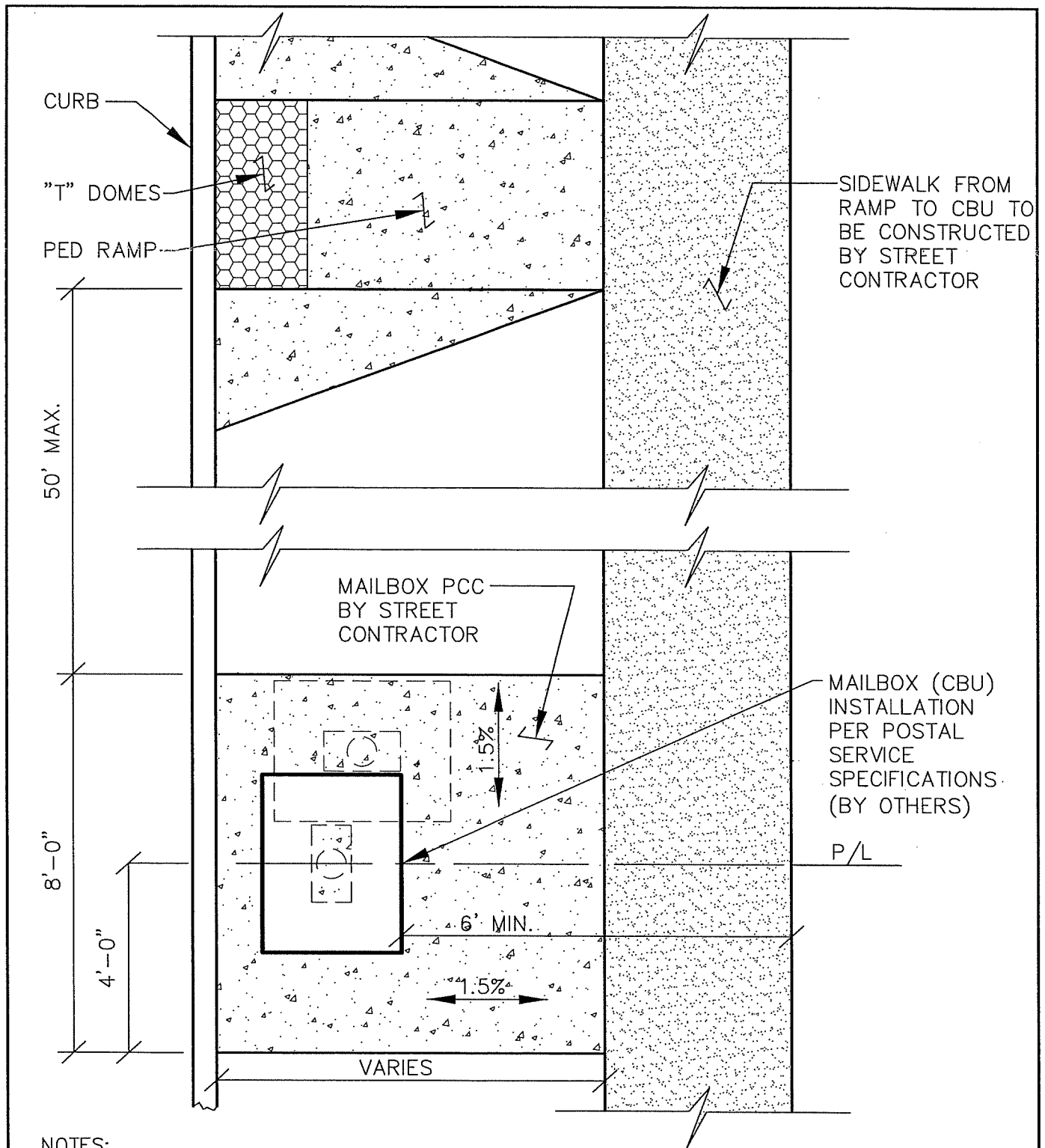

NOTES:

1. MAILBOX (CENTRALIZED BOX UNIT-CBU), LOCATION TO BE APPROVED BY LOCAL POSTMASTER
2. SET CBU 24" MIN. CLEAR BEHIND FACE OF CURB.
3. CONCRETE CBU PAD TO BE 8" THICK OR AS REQUIRED PER USPS REGULATIONS.
4. CONCRETE SHALL BE 3300 PSI @ 28 DAYS, MAX 5" SLUMP, 4.5% AIR (±1.5%).
5. ADA ACCESS TO CBU MAILBOXES SHALL CONFORM WITH SECTION 1111 OF THE OSSC (OREGON STRUCTURAL SPECIALTY CODE), INCLUDING AN ADA PEDESTRIAN CURB RAMP LOCATED WITHIN 50 FEET OF THE CBU.

LAST REVISION DATE: OCT 2021	JO #
CBU MAILBOX & RAMP W/ PROPERTY LINE SIDEWALK DETAIL (NTS)	
AUMSVILLE, OR	DETAIL NO. 213A

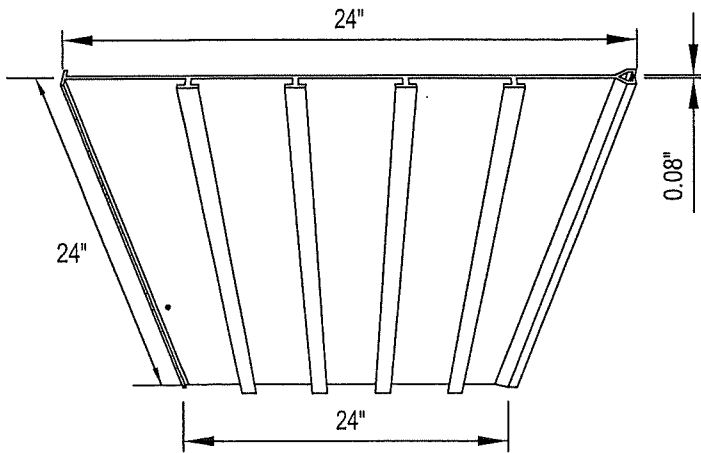

BARRIER PANEL
NTS (oblique view)

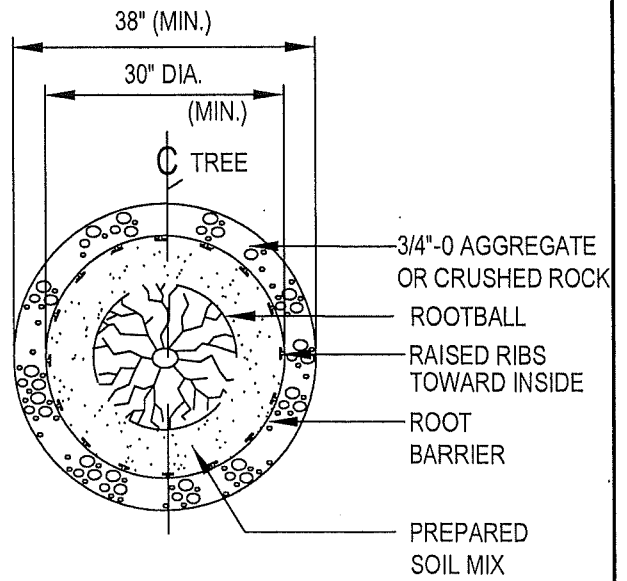

TYPE 1 (4 PANELS)
NTS

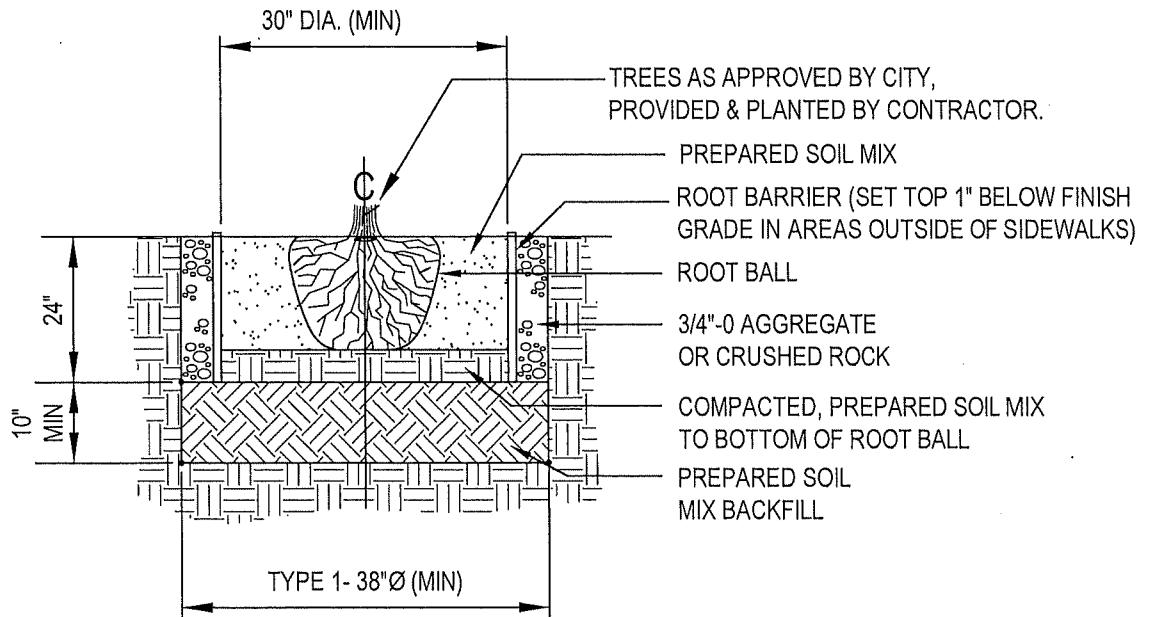

SECTION
NTS

NOTES:

1. BARRIER PANEL ASSEMBLY & INSTALLATION TO BE COMPLETED IN ACCORDANCE WITH MANUFACTURER'S SPECIFICATIONS & DRAWING/DETAIL NOTES, WHICHEVER IS MORE STRINGENT.
2. DO NOT SCALE DRAWINGS.
3. BARRIER PANELS TO BE NDS RP SERIES OR EQUAL.

LAST REVISION DATE:
FEB 2021

COPYRIGHT 1996
WESTECH ENGINEERING, INC.

**24" DEEP, 30" Ø
4 PANEL ROOT BARRIER
TREE WELLS**

(NTS)

AUMSVILLE, OR

DETAIL NO.

213B

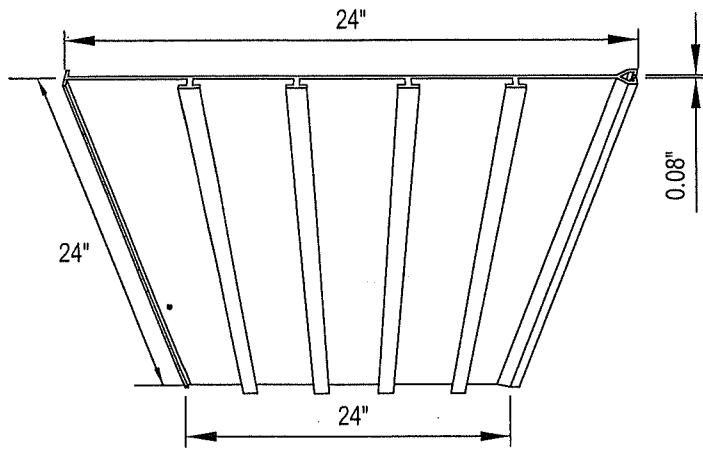

BARRIER PANEL
NTS (oblique view)

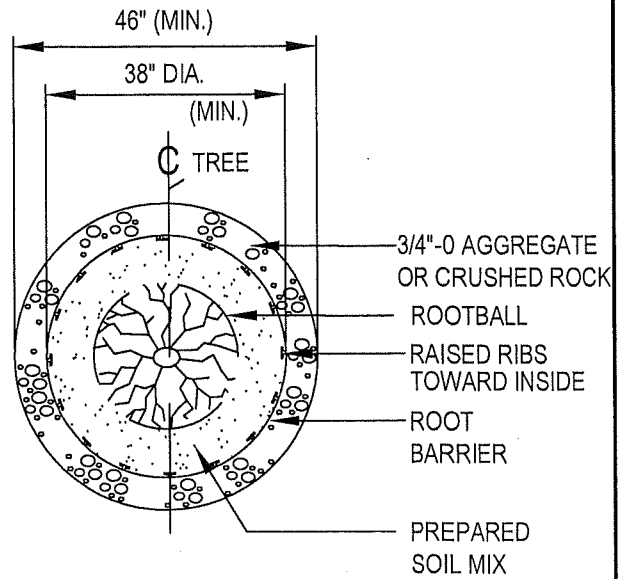

TYPE 2 (5 PANELS)
NTS

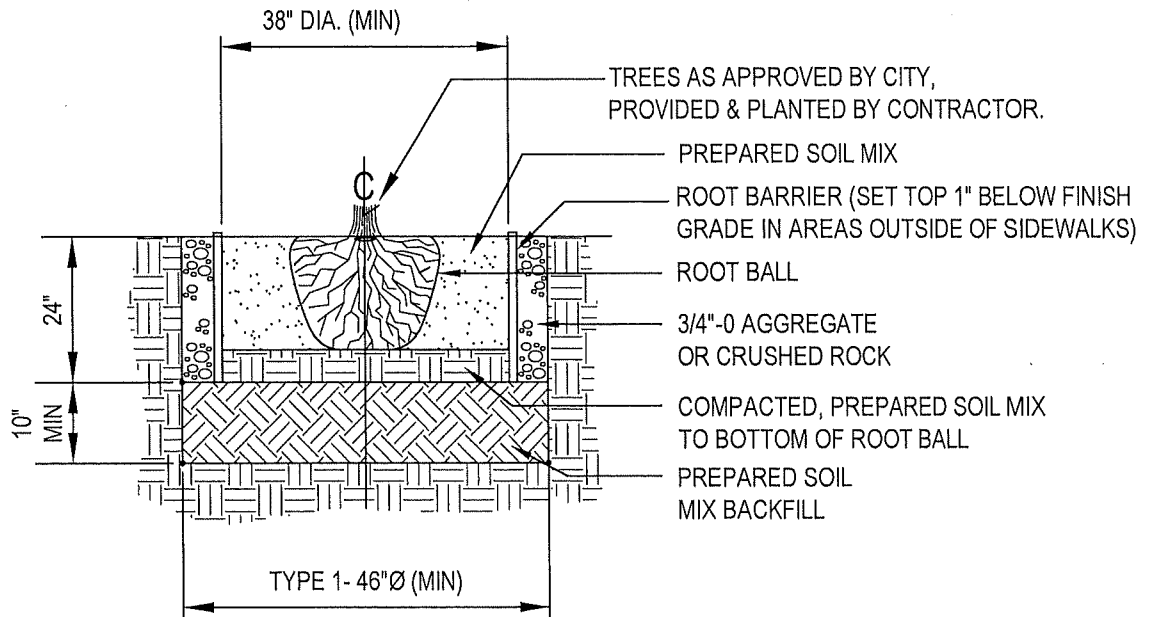

SECTION
NTS

NOTES:

1. BARRIER PANEL ASSEMBLY & INSTALLATION TO BE COMPLETED IN ACCORDANCE WITH MANUFACTURER'S SPECIFICATIONS & DRAWING/DETAIL NOTES, WHICHEVER IS MORE STRINGENT.
2. DO NOT SCALE DRAWINGS.
3. BARRIER PANELS TO BE NDS RP SERIES OR EQUAL.

LAST REVISION DATE: FEB 2021	COPYRIGHT 1996 WESTECH ENGINEERING, INC.
24" DEEP, 38" Ø 5 PANEL ROOT BARRIER TREE WELLS (NTS)	
AUMSVILLE, OR	DETAIL NO. 213C

**DOMES SHALL BE WET-SET REPLACEABLE PANELS
(ADA SOLUTIONS (CAST-IN-PLACE, BRICK RED) OR EQUAL)**

INSTALL TRUNCATED DOME DETECTABLE WARNING SURFACE AS SHOWN & SPECIFIED, **FULL WIDTH OF RAMP THROAT.**

SPACING: D=1.6" MIN. TO 2.40" MAX
0.65" MIN CLEAR BETWEEN DOME BASES

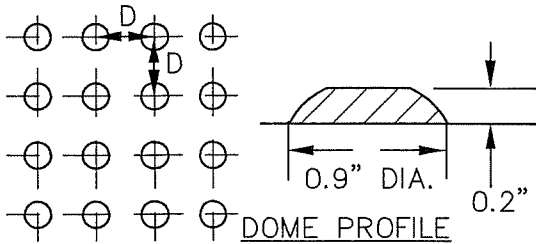
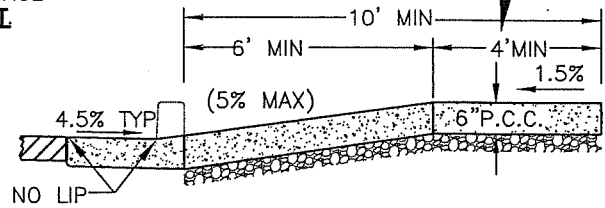

FIGURE A: TRUNCATED DOME DETAIL

5' WIDE TURNING SPACE REQUIRED WHERE LANDSCAPE CURB PROVIDED.



SECTION A

6" LANDSCAPE CURB EXPOSURE WHERE REQUIRED, SEE NOTE 9

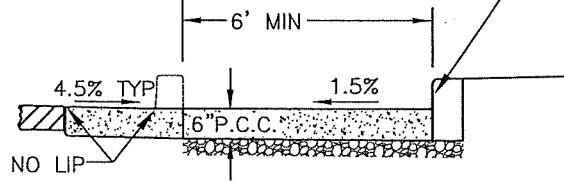

SECTION B

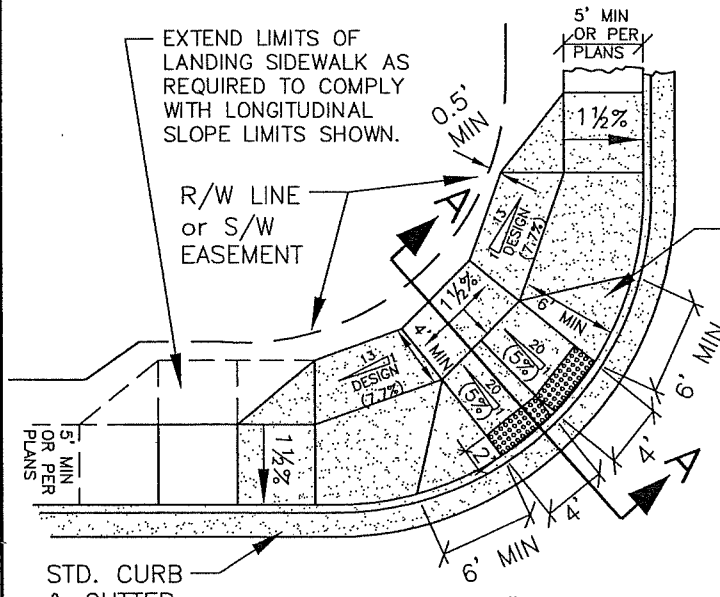

10% MAX SLOPE ON WINGS (TYP)

MONOLITHIC CURB/RAMP CONCRETE PLACEMENT ALLOWED WHERE APPROVED, TO AVOID FUTURE SETTLEMENT LIP, OR USE PINS PER DETAIL 217.

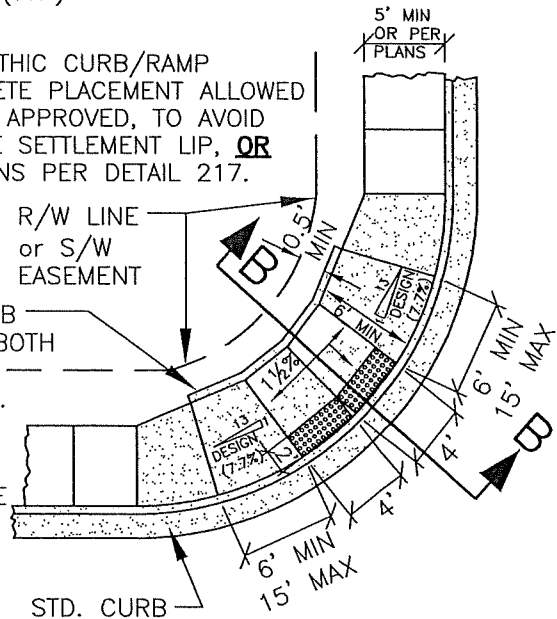

**GUTTER SLOPE AROUND RADIUS 2% MAX
(SEE SECTION B)**

STD. CURB & GUTTER

**GUTTER SLOPE 2% MAX AT CURB RAMP
(SEE SECTION A)**

6" WIDE LANDSCAPE CURB TO END OF TRANSITION BOTH WAYS WHERE REQUIRED, SEE NOTE 9, ALL RAMPS.

GENERAL NOTES:

1. SEE NOTE & DETAIL (TOP LEFT) FOR REQUIRED REPLACEABLE DOME STYLE & COLOR (PANEL OR RADIUS STYLE ALLOWED).
2. SEE TYPICAL STREET SECTIONS FOR SIDEWALK WIDTH.
3. ALL RAMPS AND TRANSITIONS SHALL BE ADA & PROWAG COMPLIANT.
4. LANDINGS & TURNING AREAS SHALL HAVE A MIN. WIDTH & DEPTH OF 4 FEET.
5. CROSS SLOPES SHOWN ARE MEASURED FROM HORIZONTAL.
6. **SHADED SIDEWALK & RAMP AREAS TO BE CONSTRUCTED W/STREET IMPROVEMENTS, AND SHALL BE 6" THICK CONCRETE.**
7. DROP CURBS FOR HANDICAP RAMPS SHALL BE CONSTRUCTED WITH NO LIP AT THE GUTTER LINE OR EDGE OF PAVEMENT.
8. TYPICALLY PROVIDE CATCH BASIN UPHILL OF PEDESTRIAN RAMP.
9. PROVIDE 6-INCH WIDE CONCRETE LANDSCAPE CURB AT BACK OF RAMP IF REQUIRED TO RETAIN LANDSCAPING, OR TO CONTAIN GUTTER DRAINAGE (IE. FOR DOWNHILL SLOPES BEHIND RAMP).
10. PROVIDE 4" MIN. COMPACTED BASEROCK UNDER ALL S/W.
11. **WHERE GRADE LIMITS SHOWN CANNOT BE SATISFIED (IE. FOR APPROACH, LANDING OR WINGS), CONSTRUCT RAMP SHOWN ON DETAIL 214B & TRANSITION TO CURBLINE SIDEWALK.**
12. DESIGN RUNNING SLOPE OF SIDEWALK APPROACH TO LANDINGS SHALL TYPICALLY NOT EXCEED 1V:13H (7.7%), BUT SHALL NOT REQUIRE THE LENGTH TO EXCEED 15 FEET.

ALL CONCRETE SHALL BE 3300 PSI @ 28 DAYS, MAX 5" SLUMP, 4.5% AIR (±1.5%).

LAST REVISION DATE:

AUG 2022

**INTERSECTION CURB RAMPS
CURB LINE SIDEWALKS
LOCAL STREETS**

(NTS)

AUMSVILLE, OR

DETAIL NO.

214A

**DOMES SHALL BE WET-SET REPLACEABLE PANELS
(ADA SOLUTIONS (CAST-IN-PLACE, BRICK RED) OR EQUAL)**

INSTALL TRUNCATED DOME DETECTABLE WARNING SURFACE AS SHOWN & SPECIFIED, **FULL WIDTH OF RAMP THROAT**.

SPACING: D=1.6" MIN. TO 2.40" MAX
0.65" MIN CLEAR BETWEEN DOME BASES

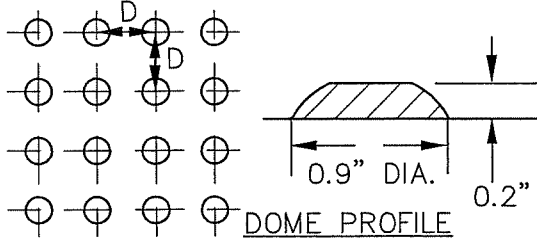
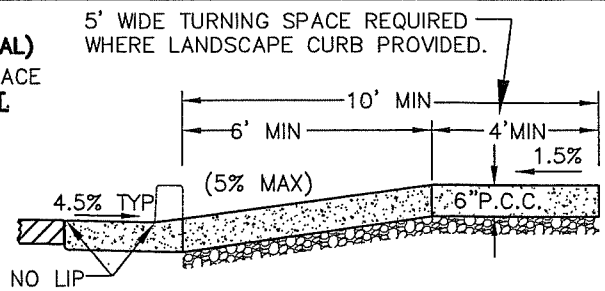
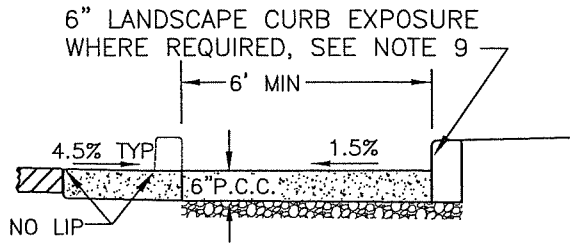

FIGURE A: TRUNCATED DOME DETAIL



SECTION A

TOOLED CONTRACTION JOINTS TYPICAL AT 5' INTERVALS (**BROOM FINISH, NO SLICKS**)



SECTION B

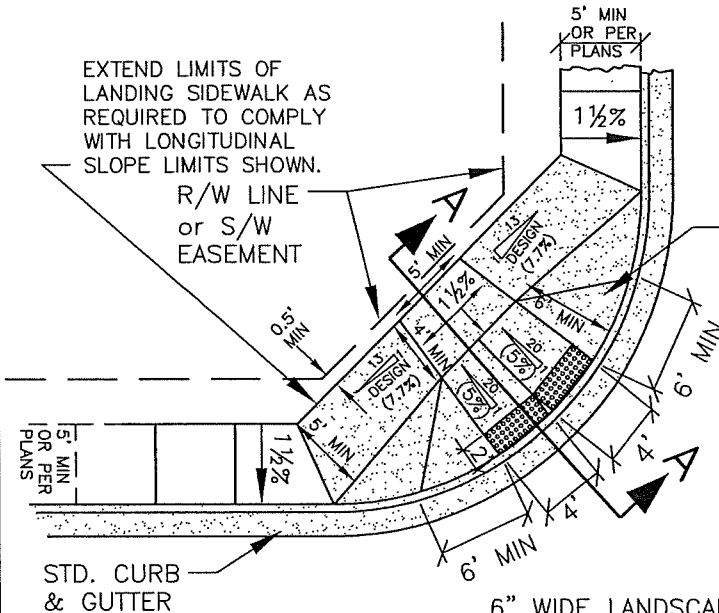

10% MAX SLOPE ON WINGS (TYP)

MONOLITHIC CURB/RAMP CONCRETE PLACEMENT ALLOWED WHERE APPROVED, TO AVOID FUTURE SETTLEMENT LIP, **OR** USE PINS PER DETAIL 217.

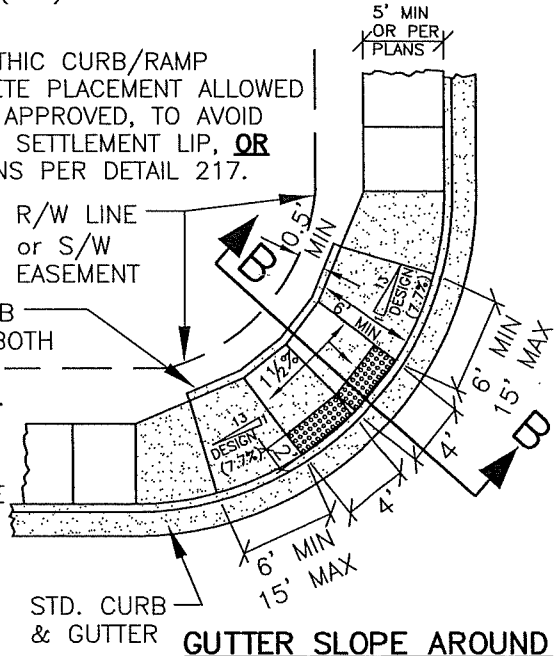

GUTTER SLOPE 2% MAX AT CURB RAMP
(SEE SECTION A)

GUTTER SLOPE AROUND RADIUS 2% MAX
(SEE SECTION B)

GENERAL NOTES:

- SEE NOTE & DETAIL (TOP LEFT) FOR REQUIRED REPLACEABLE DOME STYLE & COLOR (PANEL OR RADIUS STYLE ALLOWED).
- SEE TYPICAL STREET SECTIONS FOR SIDEWALK WIDTH.
- ALL RAMPS AND TRANSITIONS SHALL BE ADA & PROWAG COMPLIANT.
- LANDINGS & TURNING AREAS SHALL HAVE A MIN. WIDTH & DEPTH OF 4 FEET.
- CROSS SLOPES SHOWN ARE MEASURED FROM HORIZONTAL.
- SHADED SIDEWALK & RAMP AREAS TO BE CONSTRUCTED W/STREET IMPROVEMENTS, AND SHALL BE 6" THICK CONCRETE.**
- DROP CURBS FOR HANDICAP RAMPS SHALL BE CONSTRUCTED WITH NO LIP AT THE GUTTER LINE OR EDGE OF PAVEMENT.
- TYPICALLY PROVIDE CATCH BASIN UPHILL OF PEDESTRIAN RAMP.
- PROVIDE 6-INCH WIDE CONCRETE LANDSCAPE CURB AT BACK OF RAMP IF REQUIRED TO RETAIN LANDSCAPING, OR TO CONTAIN GUTTER DRAINAGE (IE. FOR DOWNHILL SLOPES BEHIND RAMP).
- PROVIDE 4" MIN. COMPACTED BASEROCK UNDER ALL S/W.
- WHERE GRADE LIMITS SHOWN CANNOT BE SATISFIED (IE. FOR APPROACH, LANDING OR WINGS), CONSTRUCT RAMP SHOWN ON DETAIL 214B & TRANSITION TO CURBLINE SIDEWALK.**
- DESIGN RUNNING SLOPE OF SIDEWALK APPROACH TO LANDINGS SHALL TYPICALLY NOT EXCEED 1V:13H (7.7%), BUT SHALL NOT REQUIRE THE LENGTH TO EXCEED 15 FEET.

ALL CONCRETE SHALL BE 3300 PSI @ 28 DAYS, MAX 5" SLUMP, 4.5% AIR (±1.5%).

LAST REVISION DATE: DEC 2022	
INTERSECTION CURB RAMPS CURB LINE SIDEWALKS LOCAL STREETS (ALT LAYOUT) (NTS)	
AUMSVILLE, OR	DETAIL NO. 214A1

DOMES SHALL BE WET-SET REPLACEABLE PANELS

(ADA SOLUTIONS (CAST-IN-PLACE, BRICK RED) OR EQUAL)

INSTALL TRUNCATED DOME DETECTABLE WARNING SURFACE AS SHOWN & SPECIFIED, **FULL WIDTH OF RAMP THROAT.**

SPACING: D=1.6" MIN. TO 2.40" MAX
0.65" MIN CLEAR BETWEEN DOME BASES

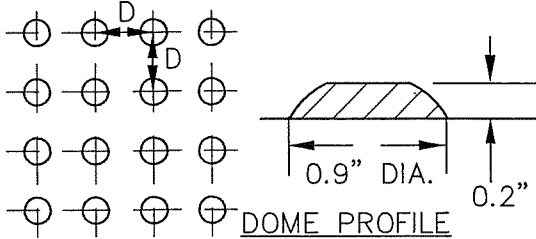
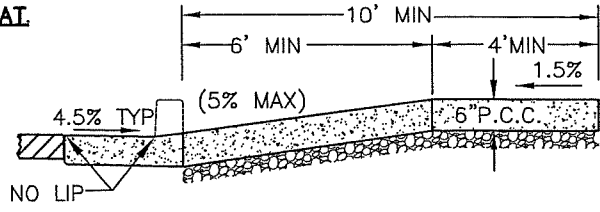

FIGURE A: TRUNCATED DOME DETAIL



SECTION

TOOLED CONTRACTION JOINTS TYPICAL AT 5' INTERVALS (BROOM FINISH, NO SLICKS)

MONOLITHIC CURB/RAMP CONCRETE PLACEMENT ALLOWED WHERE APPROVED, TO AVOID FUTURE SETTLEMENT LIP, OR USE PINS PER DETAIL 217.

USE SMOOTH CURVES FOR ANY TRANSITION TO CURBLINE SIDEWALK SHOWN ON DRAWINGS (TYP)

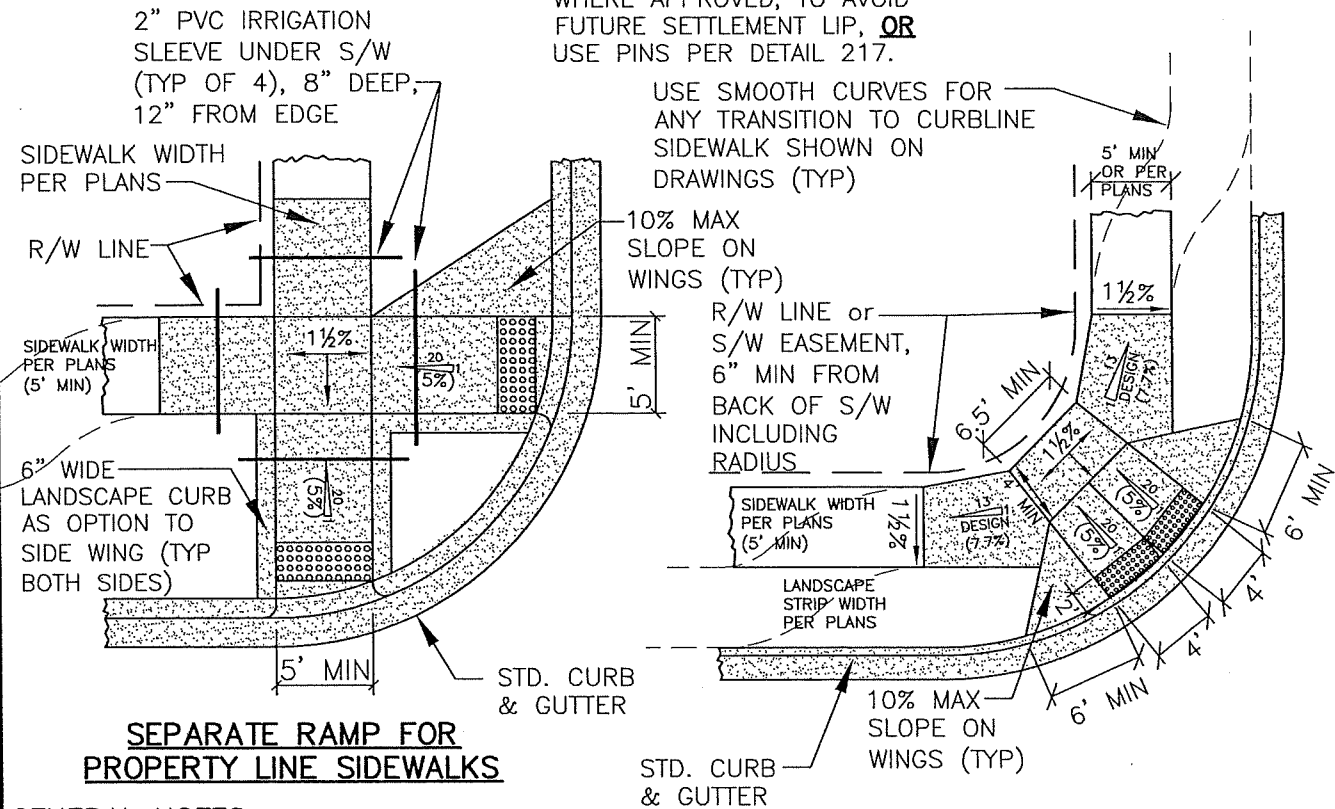

SEPARATE RAMP FOR PROPERTY LINE SIDEWALKS

DOUBLE RAMPS FOR PROPERTY LINE OR CURBLINE SIDEWALKS
(SEE SECTION A)

GENERAL NOTES:

1. SEE NOTE & DETAIL (TOP LEFT) FOR REQUIRED REPLACEABLE DOME STYLE & COLOR (PANEL OR RADIUS STYLE ALLOWED).
2. SEE TYPICAL STREET SECTIONS FOR SIDEWALK WIDTH.
3. ALL RAMPS AND TRANSITIONS SHALL BE ADA & PROWAG COMPLIANT.
4. LANDINGS & TURNING AREAS SHALL HAVE A MIN. WIDTH & DEPTH OF 4 FEET.
5. CROSS SLOPES SHOWN ARE MEASURED FROM HORIZONTAL.
6. **SHADED SIDEWALK & RAMP AREAS TO BE CONSTRUCTED W/STREET IMPROVEMENTS, AND SHALL BE 6" THICK CONCRETE.**
7. DROP CURBS FOR HANDICAP RAMPS SHALL BE CONSTRUCTED WITH NO LIP AT THE GUTTER LINE OR EDGE OF PAVEMENT.
8. TYPICALLY PROVIDE CATCH BASIN UPHILL OF PEDESTRIAN RAMP.
9. PROVIDE 4-INCH MIN RADIUS ON ALL RETURNED CURBS.
10. PROVIDE 4" MIN. COMPACTED BASEROCK UNDER ALL S/W.
11. DESIGN RUNNING SLOPE OF SIDEWALK APPROACH TO LANDINGS SHALL TYPICALLY NOT EXCEED 1V:13H (7.7%), BUT SHALL NOT REQUIRE THE LENGTH TO EXCEED 15 FEET.

ALL CONCRETE SHALL BE 3300 PSI @ 28 DAYS, MAX 5" SLUMP, 4.5% AIR (±1.5%).

LAST REVISION DATE:	JAN 2023
INTERSECTION CURB RAMPS PROPERTY LINE SIDEWALKS LOCAL STREETS	
(NTS)	
AUMSVILLE, OR	DETAIL NO. 214B

DOMES SHALL BE WET-SET REPLACEABLE PANELS

(ADA SOLUTIONS (CAST-IN-PLACE, BRICK RED) OR EQUAL)

INSTALL TRUNCATED DOME DETECTABLE WARNING SURFACE AS SHOWN & SPECIFIED, **FULL WIDTH OF RAMP THROAT**.

SPACING: D=1.6" MIN. TO 2.40" MAX
0.65" MIN CLEAR BETWEEN DOME BASES

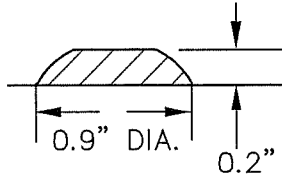
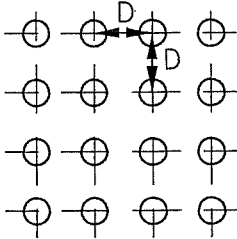

DOME PROFILE

FIGURE A: TRUNCATED DOME DETAIL

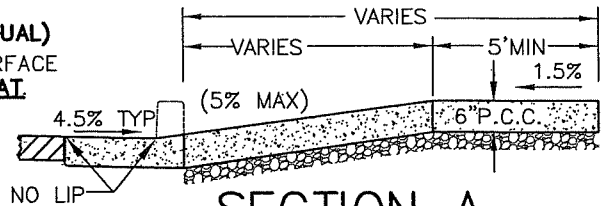

SECTION A

MONOLITHIC CURB/RAMP CONCRETE PLACEMENT ALLOWED WHERE APPROVED, TO AVOID FUTURE SETTLEMENT LIP, OR USE PINS PER DETAIL 217.

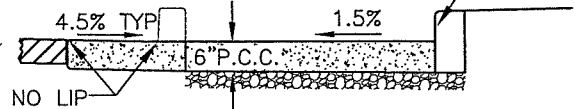

SECTION B

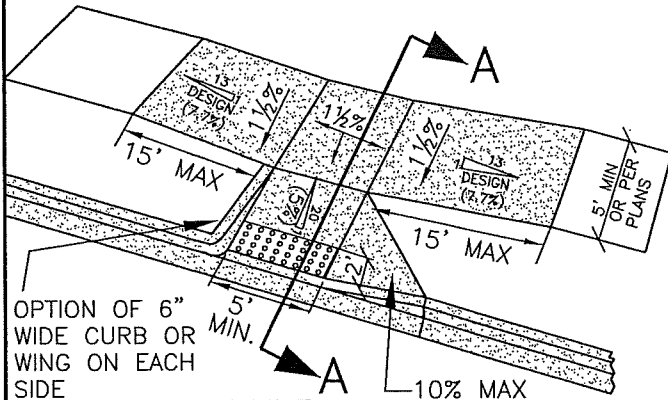

OPTION OF 6" WIDE CURB OR WING ON EACH SIDE

**PROPERTY LINE
SIDEWALK RAMP**
(SEE SECTION A)

10% MAX SLOPE ON WINGS (TYP)

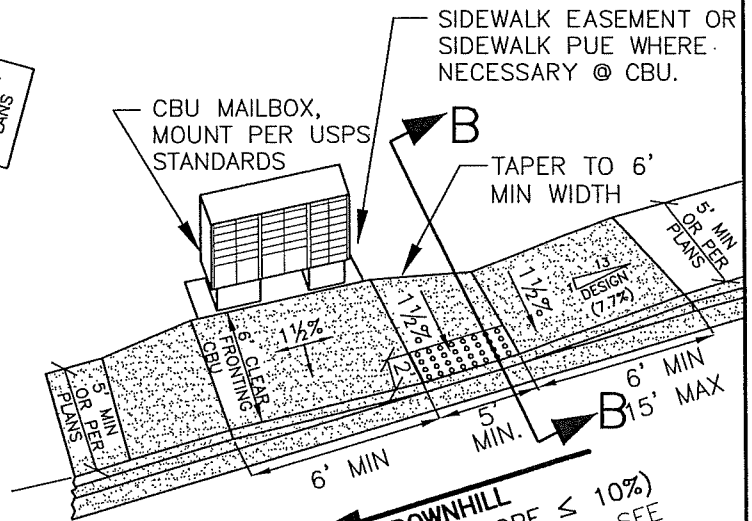

CBU MAILBOX, MOUNT PER USPS STANDARDS

SIDEWALK EASEMENT OR SIDEWALK PUE WHERE NECESSARY @ CBU.

TAPER TO 6' MIN WIDTH

DOWNHILL
(3% ≤ GUTTER SLOPE ≤ 10%)
(FOR GUTTER SLOPE < 3%, SEE LAYOUT DETAIL AT LEFT)

**CURLINE SIDEWALK RAMP
W/ADJACENT CBU**
(GUTTER SLOPE 10% MAX)
(SEE SECTION B)

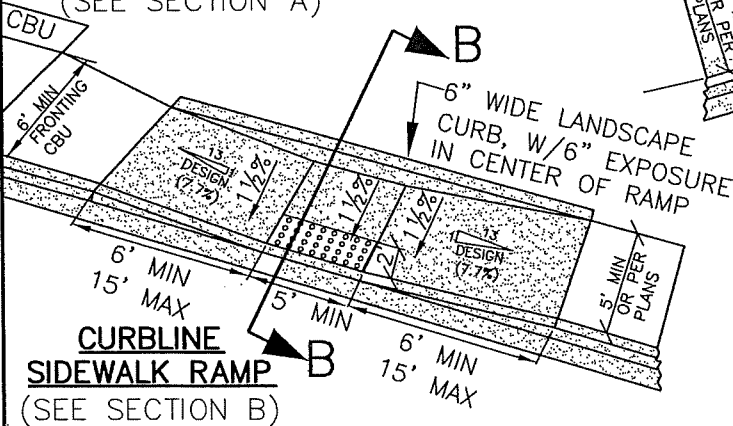

6" WIDE LANDSCAPE CURB, W/6" EXPOSURE IN CENTER OF RAMP

**CURLINE
SIDEWALK RAMP**
(SEE SECTION B)

GENERAL NOTES:

- SEE NOTE & DETAIL (TOP LEFT) FOR REQUIRED REPLACEABLE DOME STYLE & COLOR (PANELS).
- SEE TYPICAL STREET SECTIONS FOR SIDEWALK WIDTH.
- ALL RAMPS AND TRANSITIONS SHALL BE ADA & PROWAG COMPLIANT.
- LANDINGS & TURNING AREAS SHALL HAVE A MIN. WIDTH & DEPTH OF 4 FEET.
- CROSS SLOPES SHOWN ARE MEASURED FROM HORIZONTAL.
- SHADED SIDEWALK & RAMP AREAS TO BE CONSTRUCTED W/STREET IMPROVEMENTS, AND SHALL BE 6" THICK CONCRETE.**
- DROP CURBS FOR HANDICAP RAMPS SHALL BE CONSTRUCTED WITH NO LIP AT THE GUTTER LINE OR EDGE OF PAVEMENT.
- TYPICALLY PROVIDE CATCH BASIN UPHILL OF PEDESTRIAN RAMP.
- PROVIDE 4-INCH MIN RADIUS ON ALL RETURNED CURBS.
- PROVIDE 4" MIN. COMPACTED BASEROCK UNDER ALL S/W.
- DESIGN RUNNING SLOPE OF SIDEWALK APPROACH TO LANDINGS SHALL TYPICALLY NOT EXCEED 1V:13H (7.7%), BUT SHALL NOT REQUIRE THE LENGTH TO EXCEED 15 FEET.

TOOLED CONTRACTION JOINTS TYPICAL AT 5' INTERVALS (**BROOM FINISH, NO SLICKS**)

ALL CONCRETE SHALL BE 3300 PSI @ 28 DAYS, MAX 5" SLUMP, 4.5% AIR (±1.5%).

LAST REVISION DATE:
AUG 2022

CURB RAMPS BETWEEN INTERSECTIONS

(NTS)

AUMSVILLE, OR

DETAIL NO.

214C

ALL CONCRETE SHALL BE 3300 PSI @ 28 DAYS, MAX 5" SLUMP, 4.5% AIR (±1.5%).

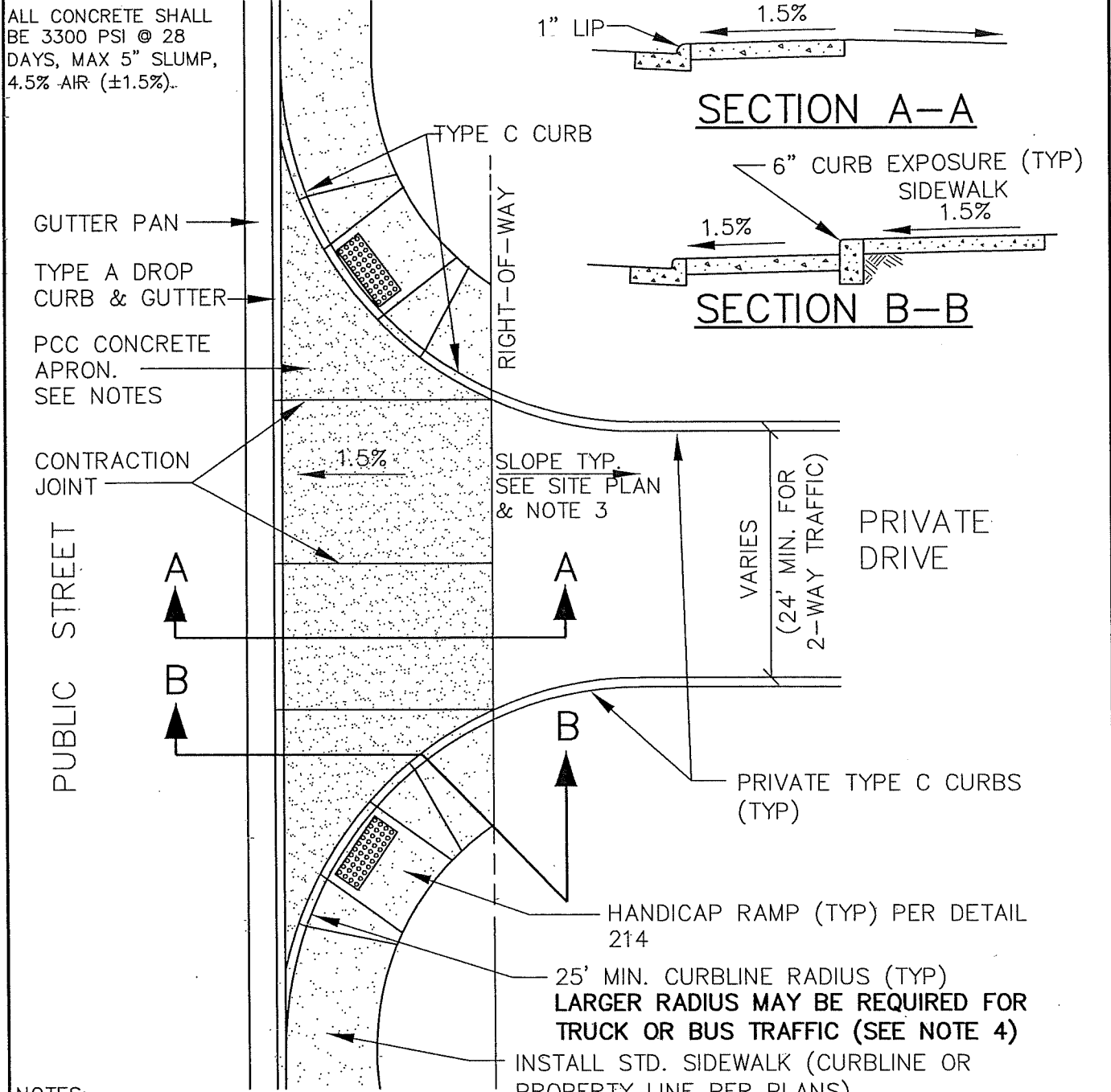

NOTES:

1. WHERE APPROVED BY THE CITY ENGINEER & PUBLIC WORKS DIRECTOR, "DUSTPAN" STYLE COMMERCIAL DRIVEWAYS PER DETAILS 212 OR 213 MAY BE USED (BASED ON CONCRETE THICKNESS/REINFORCING AS NOTED HEREIN).
2. CONCRETE APRON BE 8" MIN. THICK 3300 PCC WITH #3 REBAR @ 12" O.C. EACH WAY, OR 6"x6" 10 GA. WELDED WIRE MESH, SET ON 3" DOBIES (IE. 3" CLEAR TO BASEROCK).
3. MIN. 4" OF 3/4"-0" COMPACTED GRANULAR BASEROCK (TYPICAL UNDER ALL SIDEWALKS AND CONCRETE DRIVEWAY APPROACHES).
4. PRIVATE CATCH BASINS ARE REQUIRED BEHIND DRIVEWAY APRON IF THE DRIVEWAY OR THE PARKING LOT BEYOND DRIVEWAY APRON SLOPES & DRAINS TOWARD THE STREET (OR ACROSS A PEDESTRIAN PATH).
5. TURNING RADIUS OF ANTICIPATED LARGEST VEHICLE TO BE VERIFIED DURING DESIGN.
6. **MONOLITHIC CURB & DRIVEWAY APRON PLACEMENT IS NOT PERMITTED (IE. CURB CONCRETE & DRIVEWAY APRON CONCRETE SHALL BE PLACED SEPARATELY).**

LAST REVISION DATE: DEC 2022	COPYRIGHT 1996 WESTECH ENGINEERING, INC.
COMMERCIAL/INDUSTRIAL DRIVEWAY APPROACH, HIGH-VOLUME/TRUCK OPTION (NTS)	
AUMSVILLE, OR	DETAIL NO. 216

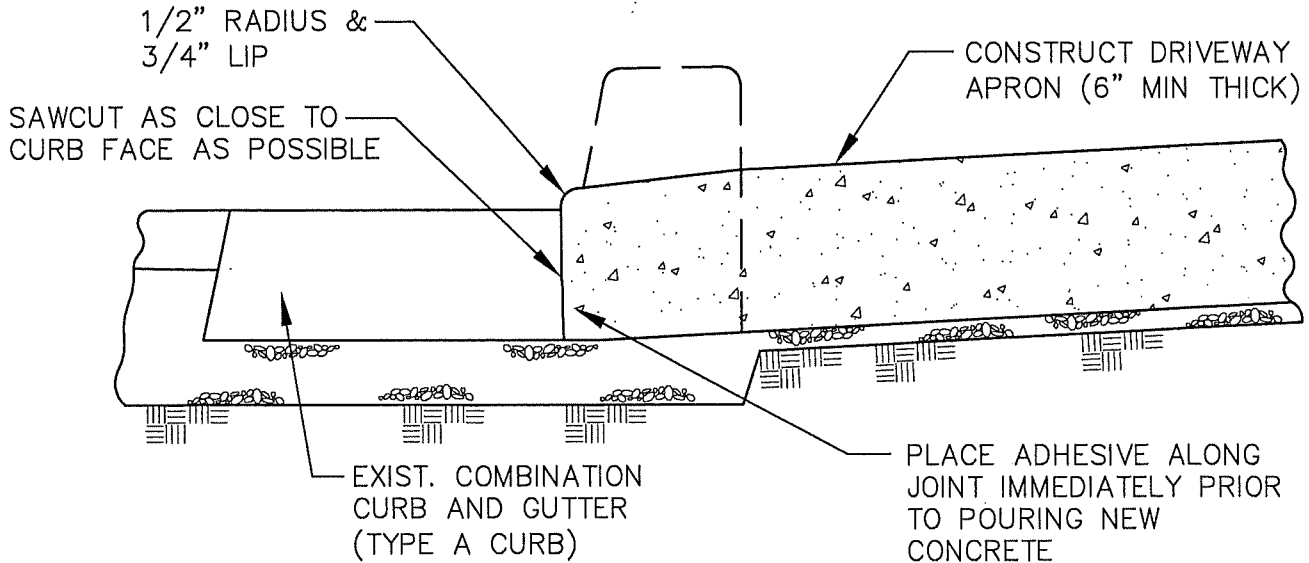

NEW DRIVEWAY APPROACH (CURB & GUTTER)

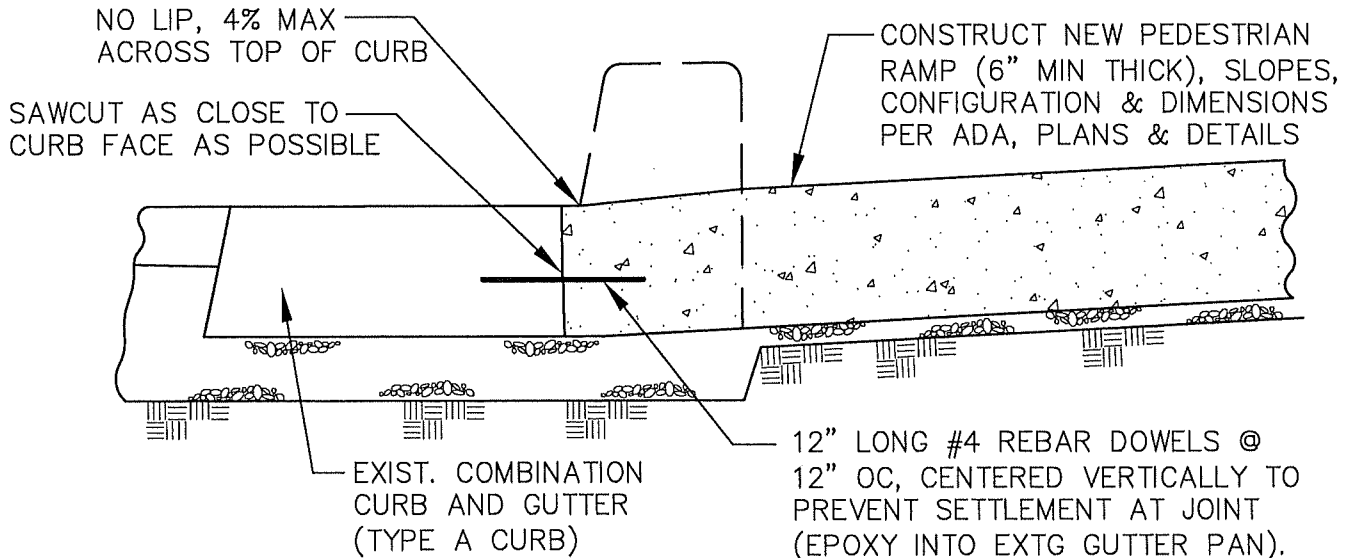

NEW PEDESTRIAN RAMP (CURB & GUTTER)

NOTES:

1. ONLY ALLOWED ON EXISTING PAVED STREETS.
2. HORIZONTAL SAWCUTTING OR GRINDING OF CURB TO MATCH NEW APPROACH PROFILE IS ALSO ALLOWED.
3. SAWCUT THROUGH GUTTER PAN SHALL BE MADE AS CLOSE TO CURB FACE AS POSSIBLE.
4. COMPLETE CURB AND GUTTER SHALL NOT BE REMOVED UNLESS APPROVED IN WRITING BY THE CITY ENGINEER PRIOR TO START OF CONSTRUCTION.
5. WHEN TYPE 'C' FULL DEPTH CURBS ARE REMOVED, A MIN OF 2 FEET OF PAVEMENT (MEASURED FROM THE FACE OF CURB) SHALL BE REMOVED AND REPLACED UNLESS OTHERWISE APPROVED BY THE CITY.
6. ANY AC SAWCUTS WILL REQUIRE A BENCH GRIND (PER DETAILS 302A & 302B) IN CONJUNCTION WITH REPAVING.

ALL CONCRETE SHALL BE 3300 PSI @ 28 DAYS, MAX 5" SLUMP, 4.5% AIR (±1.5%).

LAST REVISION DATE:

FEB 2022

COPYRIGHT 1996
WESTECH ENGINEERING, INC.

**CURB CUT FOR NEW
DRIVEWAYS OR PEDESTRIAN
RAMP ON EXISTING CURB**

(NTS)

DETAIL NO.

AUMSVILLE, OR

217

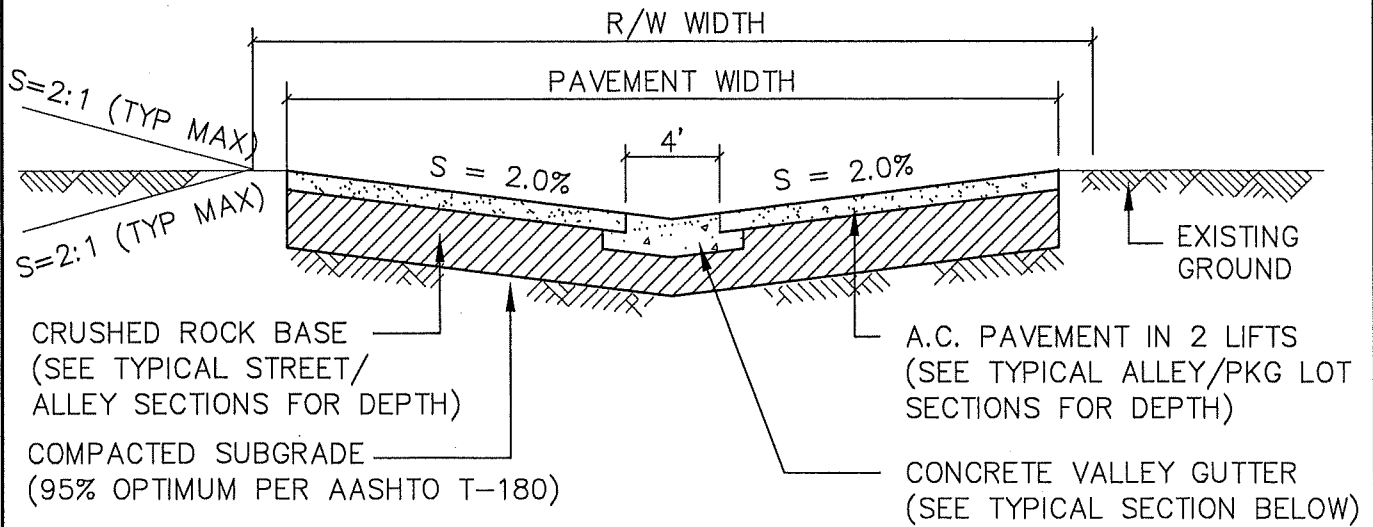

NOTE:
 DESIGN ALLEY CROSS-SLOPE OF 2% MAY VARY FROM 1.5% TO 4% TO PROVIDE POSITIVE DRAINAGE AND MATCH EXISTING GRADE. CONTRACTOR TO OBTAIN CITY APPROVAL FOR ANY VARIATION OF DESIGN GRADES.

TYPICAL VALLEY GUTTER LOCATION

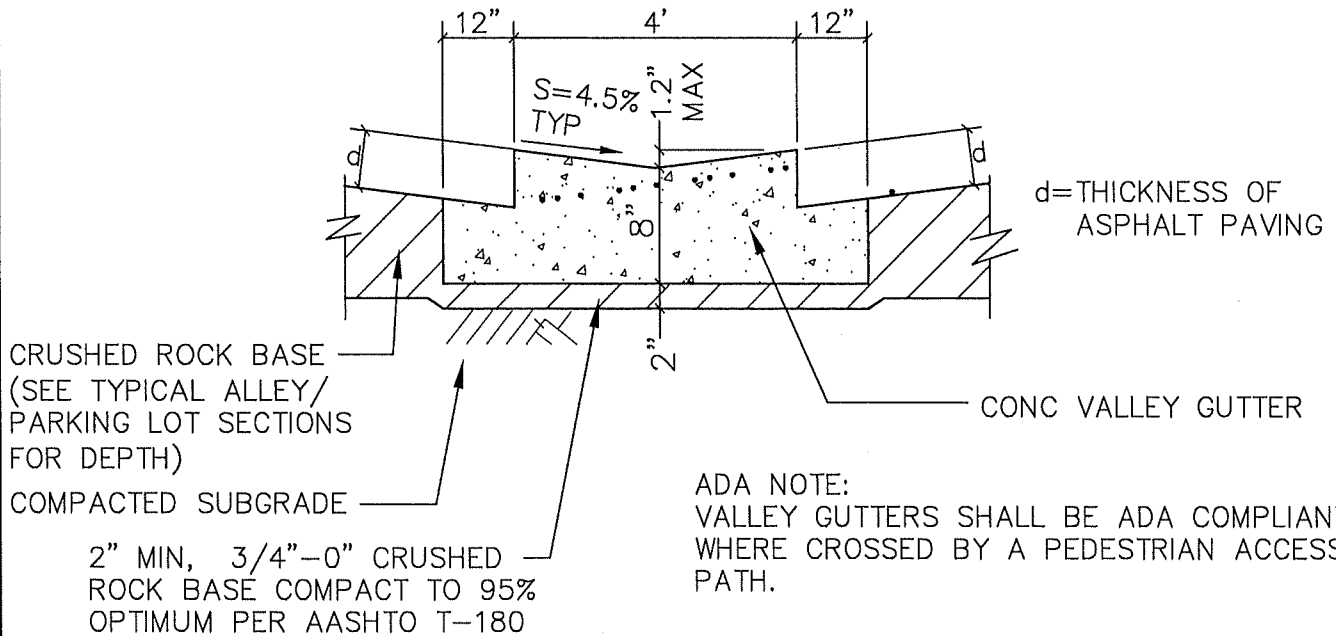

TYPICAL CONCRETE GUTTER SECTION

NOTES:

1. CONTRACTION JOINTS SHALL BE PLACED AT 15' MIN. INTERVALS AND SHALL EXTEND AT LEAST 50% THROUGH THE GUTTER SECTION.
2. CONSTRUCT 12" WIDE BENCH MONOLITHICALLY WITH VALLEY GUTTER FOR PAVEMENT SUPPORT. BENCH DEPTH TO MATCH PAVEMENT THICKNESS.
3. VALLEY GUTTERS PROPOSED AT PUBLIC STREET INTERSECTIONS MUST BE APPROVED ON A CASE-BY-CASE BASIS BY THE PUBLIC WORKS DIRECTOR.

ALL CONCRETE SHALL BE 3300 PSI @ 28 DAYS, MAX 5" SLUMP, 4.5% AIR (±1.5%).

LAST REVISION DATE: FEB 2021	
CONCRETE VALLEY GUTTER (TYP FOR USE IN ALLEYS AND PARKING LOTS)	
(NTS)	
AUMSVILLE, OR	DETAIL NO. 218

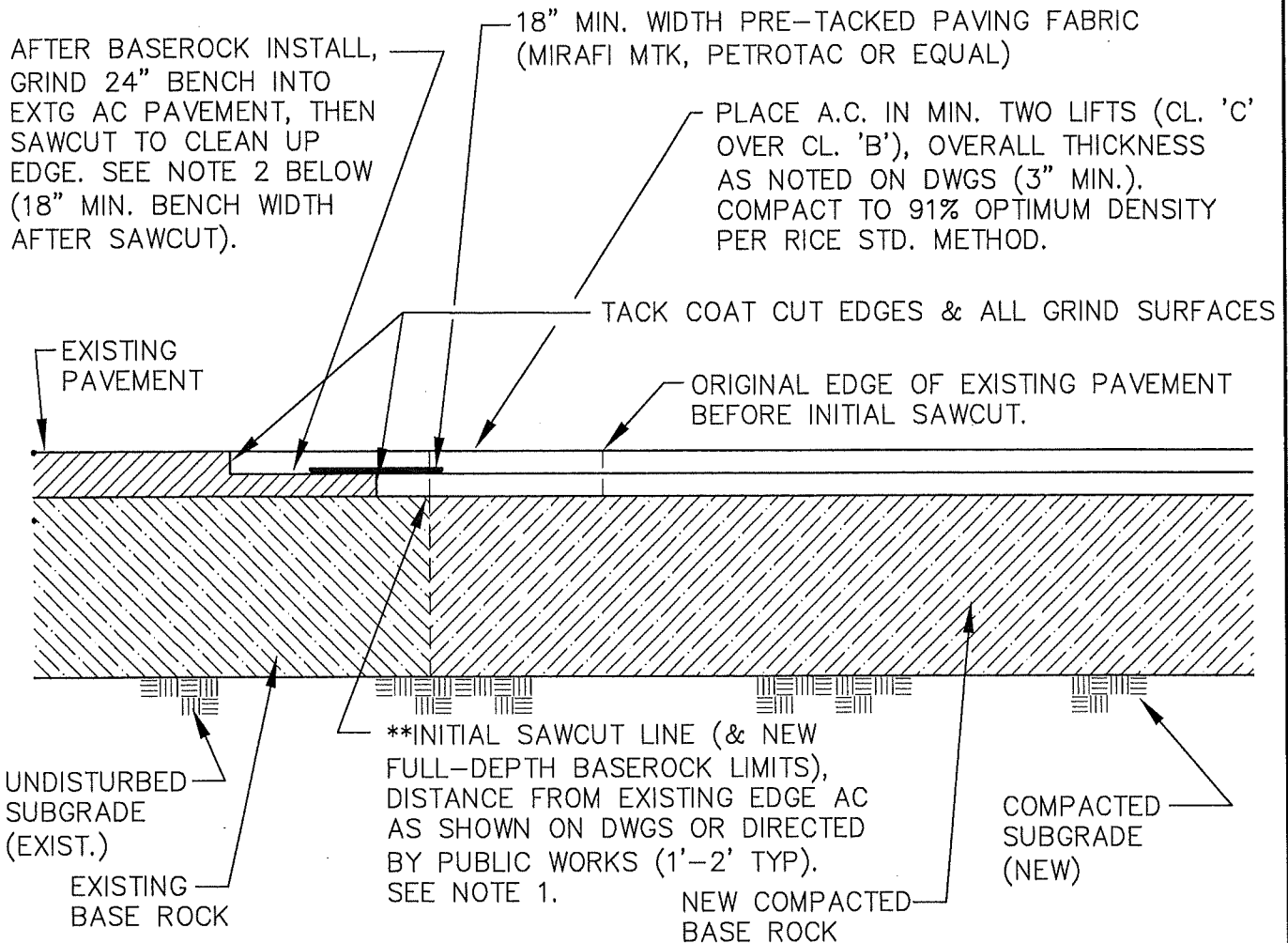

****BENCH GRIND REQUIREMENT SHOWN DOES NOT REPLACE ANY REQUIREMENT NOTED ON DRAWINGS FOR SAWCUT BACK FROM EDGE OF EXISTING AC & INSTALLATION OF NEW BASEROCK. BENCH GRIND REQUIREMENT APPLIES AFTER ALL EXCAVATION & BASEROCK PLACEMENT (PRIOR TO PAVING), TO AVOID FULL DEPTH AC JOINTS.**

NOTES:

1. INITIAL SAWCUT SHOWN ABOVE** TO OCCUR PRIOR TO EXCAVATION FOR NEW BASEROCK. SAWCUT LIMITS (& NEW BASEROCK LIMITS) MAY BE INCREASED BY PUBLIC WORKS BASED ON ACTUAL FIELD CONDITIONS (IE. INADEQUATE BASEROCK AT TRANSITION POINT; ETC.).
2. AFTER INSTALLATION OF NEW BASEROCK (PRIOR TO PAVING), GRIND 24" WIDE BENCH ALONG EDGE OF EXISTING AC (2" DEEP TYP), THEN SAWCUT TO CLEAN UP EDGE AS REQUIRED (FINISHED BENCH GRIND TO EXTEND TO A POINT 18" MINIMUM FROM FINAL SAWCUT LOCATION).
3. TACK COAT CUT EDGES AND INSTALL BASE LIFT OF AC LEVEL WITH BENCH GRIND.
4. INSTALL PAVING FABRIC AT ALL JOINTS, TACK COAT ALL GRIND SURFACES & EDGES, INSTALL TOP LIFT OF AC.
5. SAND SEAL ALL JOINTS (REMOVE EXCESS SAND AFTER CURE).
6. **ALONG WIDENED STREETS, THE CONTRACTOR SHALL VERIFY THAT THE PROPOSED CURB/GUTTER ELEVATIONS MATCH THE EXISTING EDGE OF PAVEMENT, BASED ON THE DESIGN STREET CROSS SLOPES SHOWN ON THE DRAWINGS AND THE SPECIFIED CURB EXPOSURE. ANY DISCREPANCIES SHALL BE REPORTED TO THE ENGINEER PRIOR TO PLACEMENT OF CURB FORMS OR STRINGLINE. CURBS WHICH ARE PLACED TOO HIGH OR TOO LOW SHALL BE REMOVED AND REPLACED AS DIRECTED BY THE CITY.**

LAST REVISION DATE: FEB 2021	
AC STREET CUT FOR STREET WIDENING OR EXTENSION (NTS)	
AUMSVILLE, OR	DETAIL NO. 219

FIRE CODE NOTES:

- A) FIRE LANES, TURNAROUNDS & ASSOCIATED IMPROVEMENTS SHALL COMPLY WITH THE MOST CURRENT VERSION OF THE OREGON FIRE CODE (OFC).
- B) GRADES ALONG FIRE LANES OR ALONG TURNAROUND AREAS SHALL NOT EXCEED 10% WITHOUT PRIOR WRITTEN APPROVAL FROM THE FIRE CODE OFFICIAL (OFC D103.2).
- C) NARROWER FIRE LANE WIDTHS BEYOND TURNAROUND MUST BE APPROVED IN WRITING AS AN EXCEPTION BY THE FIRE CODE OFFICIAL (OFC 503.2.2)

BASEROCK & PAVEMENT:

- A) MIN FIRE LANE & TURNAROUND BASEROCK & PAVEMENT THICKNESSES ARE SPECIFIED UNDER PWDS 2.31.c (3" AC/9" BASEROCK OR 8" PCC/2" BASEROCK, EITHER OVER COMPACTED SUBGRADE).
- B) OTHER DURABLE HARD SURFACES SHALL PROVIDE EQUIVALENT BEARING STRENGTH (SEE PWDS 2.30.f). PLAIN GRAVEL SURFACES DO NOT MEET CITY STANDARDS.

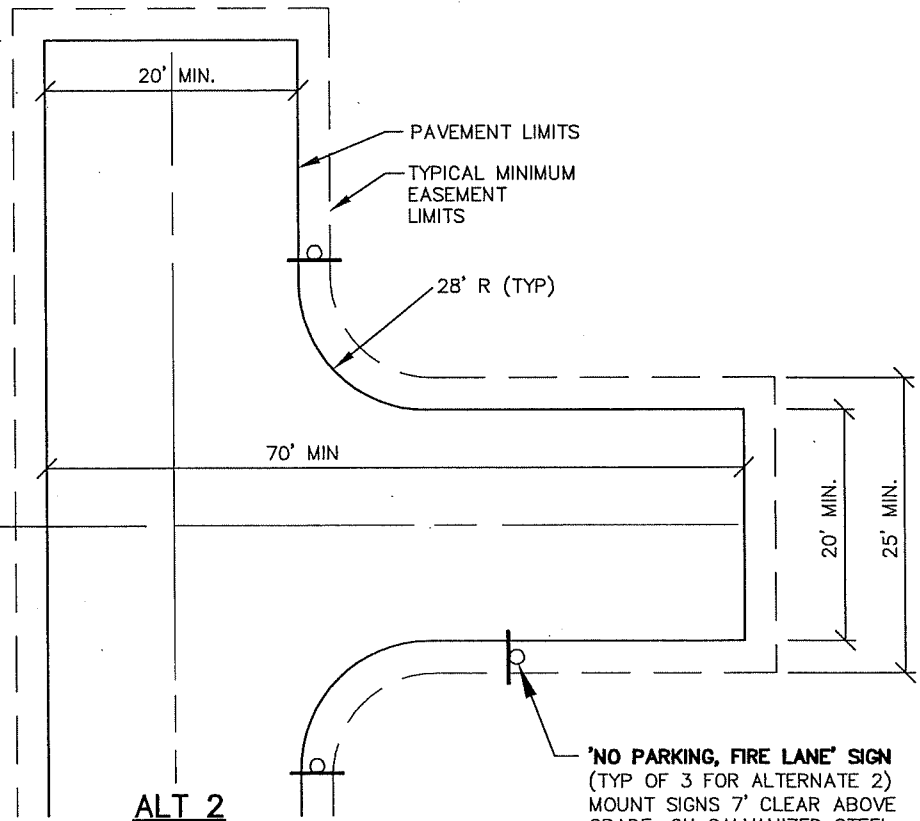

ALT 2

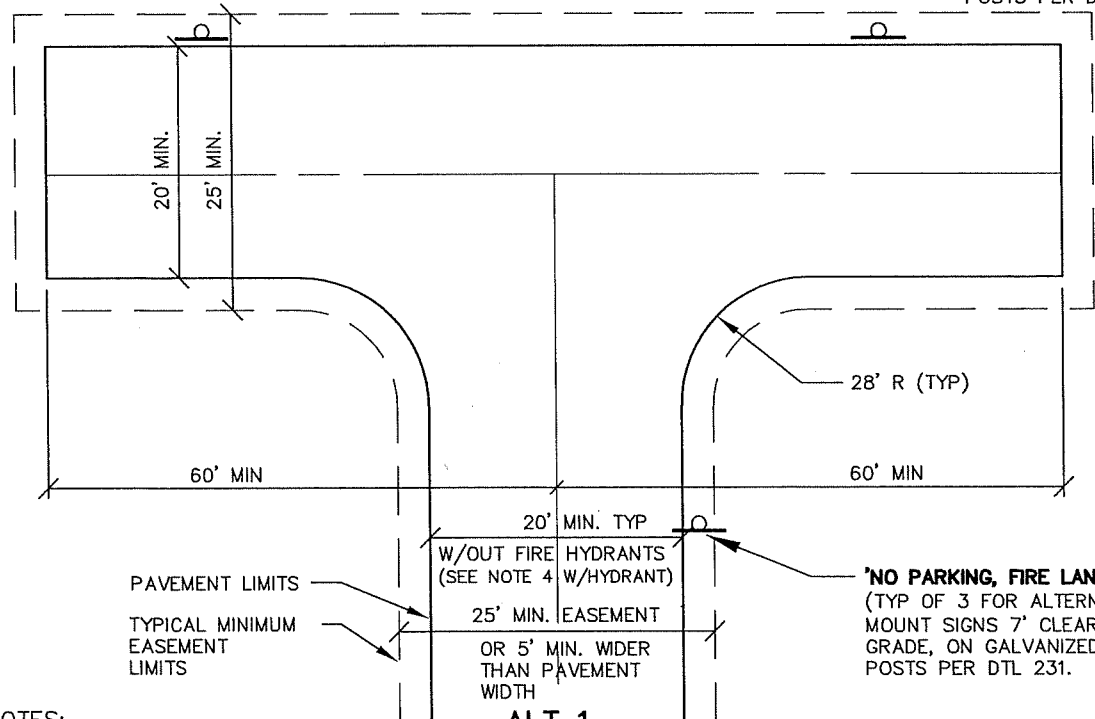

ALT 1

NOTES:

- 1. 'NO PARKING/FIRE LANE' ALUM SIGNS REQUIRED AT TURN-AROUND AS SHOWN, & AT 50 FOOT MAXIMUM INTERVALS ALONG LENGTH OF FIRE LANE (SIGN SIZE/WORDING PER OFC D103.6, SIGNS TO BE SET ON ALTERNATING SIDES OF STEM FOR FIRE LANE WIDTHS ≤26 FEET).
- 2. THESE ARE TYPICAL MINIMUM DESIGNS AS REQUIRED BY THE 2019 OFC D103.4 & FIGURE D103.1. ALTERNATE DESIGNS SHALL MEET THE APPROVAL OF THE LOCAL FIRE CODE OFFICIAL.
- 3. FIRE LANES & TURNAROUNDS MUST BE PAVED OR HARD SURFACED AS NOTED ABOVE. PAVEMENT DIMENSIONS SHOWN REFERS TO TOTAL DRIVABLE WIDTH BETWEEN CURBS (IF CURBS ARE PRESENT).
- 4. 26' MIN. PAVEMENT WIDTH REQ'D AT FIRE HYDRANTS (OFC D103.1), FOR 20 FEET MINIMUM EACH WAY FROM HYDRANT.

LAST REVISION DATE: DEC 2022	COPYRIGHT 1996 WESTECH ENGINEERING, INC.
FIRE CODE/FIRE LANE HAMMERHEAD TURNAROUND (PRIVATE DRIVES ONLY) (NTS)	
AUMSVILLE, OR	DETAIL NO. 220

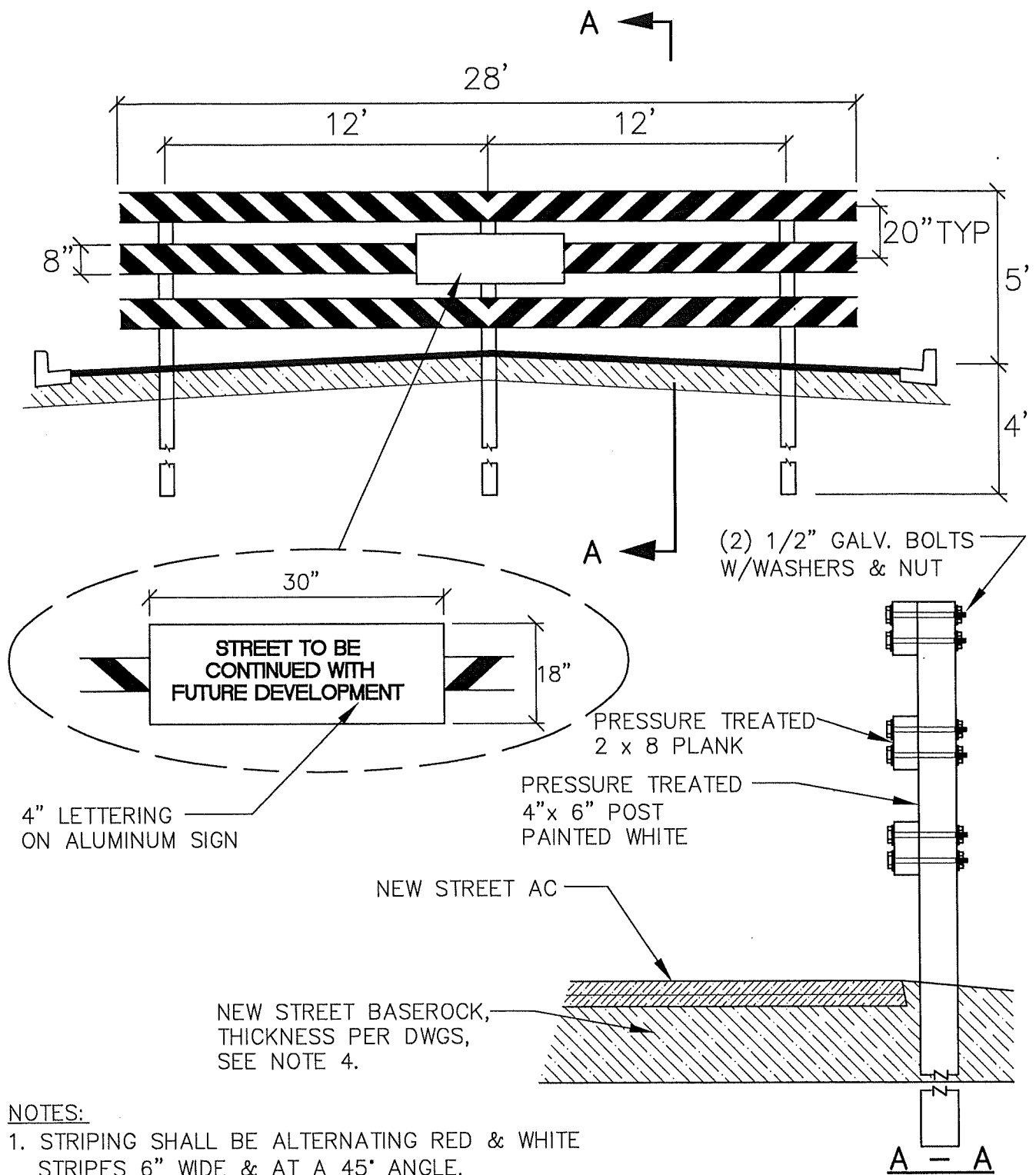

NOTES:

1. STRIPING SHALL BE ALTERNATING RED & WHITE STRIPES 6" WIDE & AT A 45° ANGLE.
2. STRIPING SHALL BE EITHER RETRO-REFLECTIVE TAPE OR PAINTED WITH A SEALED RETRO-REFLECTIVE SURFACE.
3. BARRICADE SHALL BE LOCATED WITHIN THE RESERVE STRIP, IF PRESENT.
4. FULL DEPTH BASEROCK SHALL EXTEND BEYOND BARRICADE POSTS AS SHOWN.

LAST REVISION DATE: FEB 2021	COPYRIGHT 1996 WESTECH ENGINEERING, INC.
STREET BARRICADE (STUB STREETS)	
(NTS)	
AUMSVILLE, OR	DETAIL NO. 225

BOLLARDS POSTS WHICH ARE FINISH PAINTED PRIOR TO INSTALLATION SHALL HAVE EXPOSED PORTION WRAPPED WITH PLASTIC PRIOR TO BASE CONCRETE & FILL CONCRETE PLACEMENT.

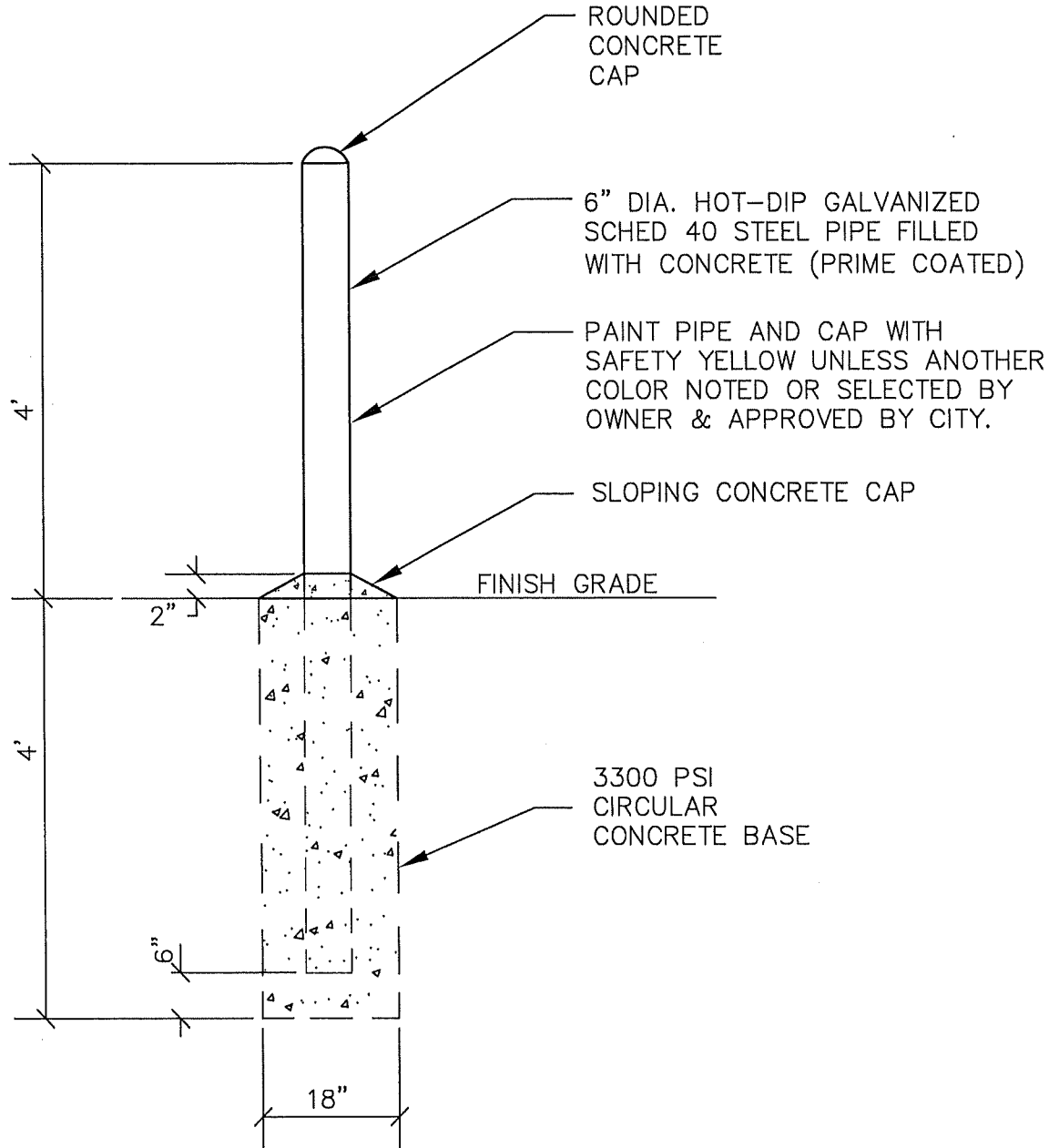

NOTES:

1. IF BOLLARDS ARE PLACED IN AC PAVEMENT OR CONCRETE AREAS, HOLES FOR THE CONCRETE ANCHOR BASE SHALL BE CORE DRILLED TO DIMENSIONS SHOWN.
2. CONTRACTOR SHALL COORDINATE WITH OWNER'S REPRESENTATIVE FOR INSPECTION OF BASE HOLES (DIAMETER & DEPTH) PRIOR TO CONCRETE PLACEMENT.

LAST REVISION DATE: MAR 2022	COPYRIGHT 1996 WESTECH ENGINEERING, INC.
6-INCH BOLLARD (GUARD POST)	
(NTS)	
AUMSVILLE, OR	DETAIL NO. 226

BOLLARDS POSTS WHICH ARE FINISH PAINTED PRIOR TO INSTALLATION SHALL HAVE EXPOSED PORTION WRAPPED WITH PLASTIC PRIOR TO BASE CONCRETE & FILL CONCRETE PLACEMENT.

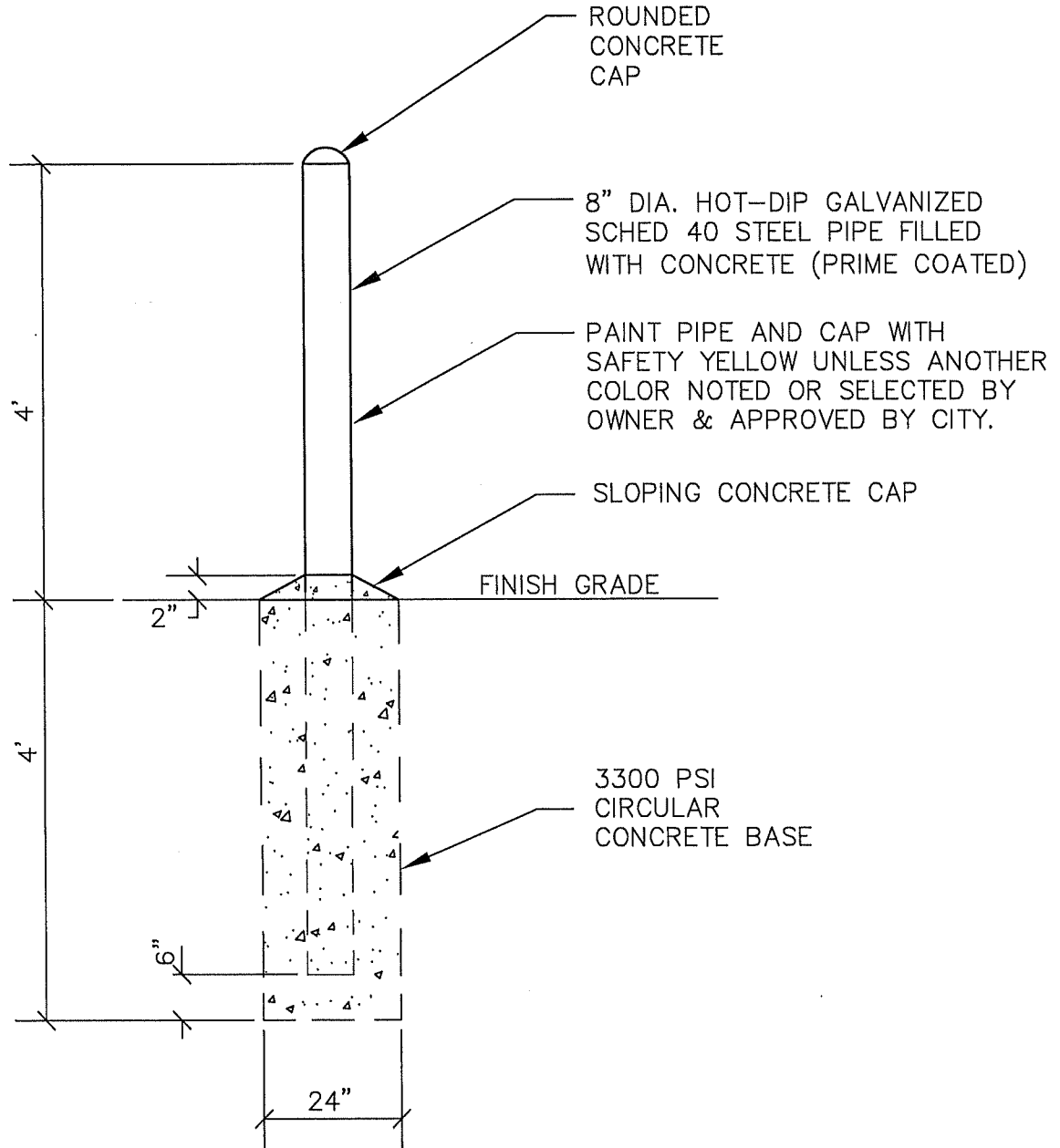

NOTES:

1. IF BOLLARDS ARE PLACED IN AC PAVEMENT OR CONCRETE AREAS, HOLES FOR THE CONCRETE ANCHOR BASE SHALL BE CORE DRILLED TO DIMENSIONS SHOWN.
2. CONTRACTOR SHALL COORDINATE WITH OWNER'S REPRESENTATIVE FOR INSPECTION OF BASE HOLES (DIAMETER & DEPTH) PRIOR TO CONCRETE PLACEMENT.
3. 8" BOLLARD TYPICALLY ONLY REQUIRED FOR LARGE COMMERCIAL/INDUSTRIAL TRUCK TRAFFIC.

LAST REVISION DATE: MAR 2022	COPYRIGHT 1996 WESTECH ENGINEERING, INC.
8-INCH BOLLARD (GUARD POST)	
(NTS)	
AUMSVILLE, OR	DETAIL NO. 227

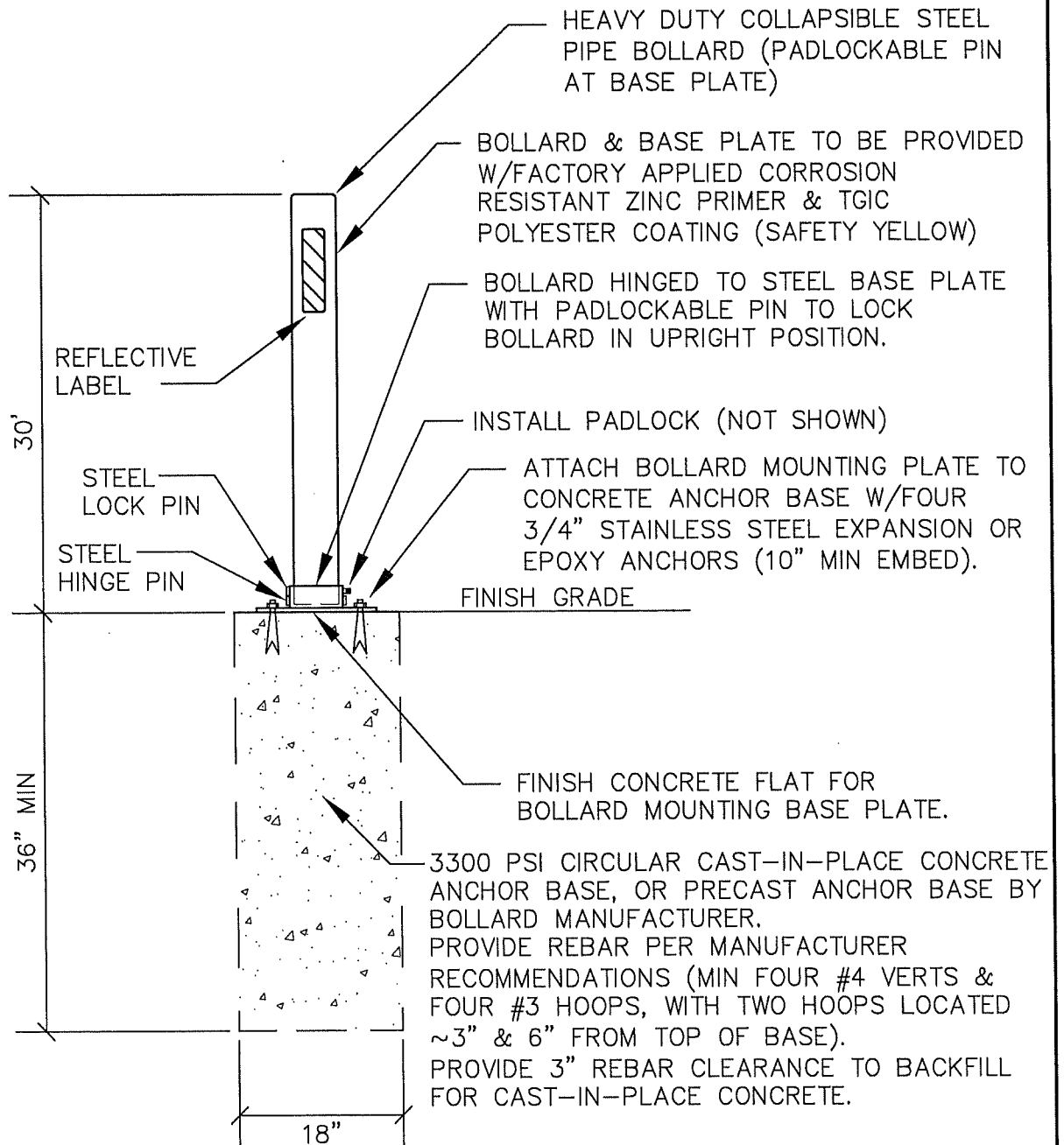

NOTES:

1. BOLLARD BASE MOUNTING PLATE AND BOLLARD SHALL BE 4-INCH MAXIMUM HEIGHT WHEN IN COLLAPSED/DOWN POSITION.
2. UNLESS OTHERWISE SPECIFIED, PROVIDE WEATHER RESISTANT PADLOCK KEYED TO SPECIFIED PATTERN.
3. COLLAPSIBLE BOLLARD ASSEMBLY SHALL BE TRAFFIC-GUARD MODEL LPHDHB OR APPROVED EQUAL.
4. VERIFY BOLLARD HINGE LOCATION (IE. COLLAPSE DIRECTION) WITH OWNER PRIOR TO INSTALLATION.
5. IF BOLLARDS ARE PLACED IN AC PAVEMENT OR CONCRETE AREAS, HOLES FOR THE CONCRETE ANCHOR BASE SHALL BE CORE DRILLED TO DIMENSIONS SHOWN.
6. CONTRACTOR SHALL COORDINATE WITH OWNER'S REPRESENTATIVE FOR INSPECTION OF BASE HOLES (DIAMETER & DEPTH) PRIOR TO CONCRETE PLACEMENT.

LAST REVISION DATE: MAR 2022	
30" TALL COLLAPSIBLE PADLOCKABLE BOLLARD	
(NTS)	
AUMSVILLE, OR	DETAIL NO. 228

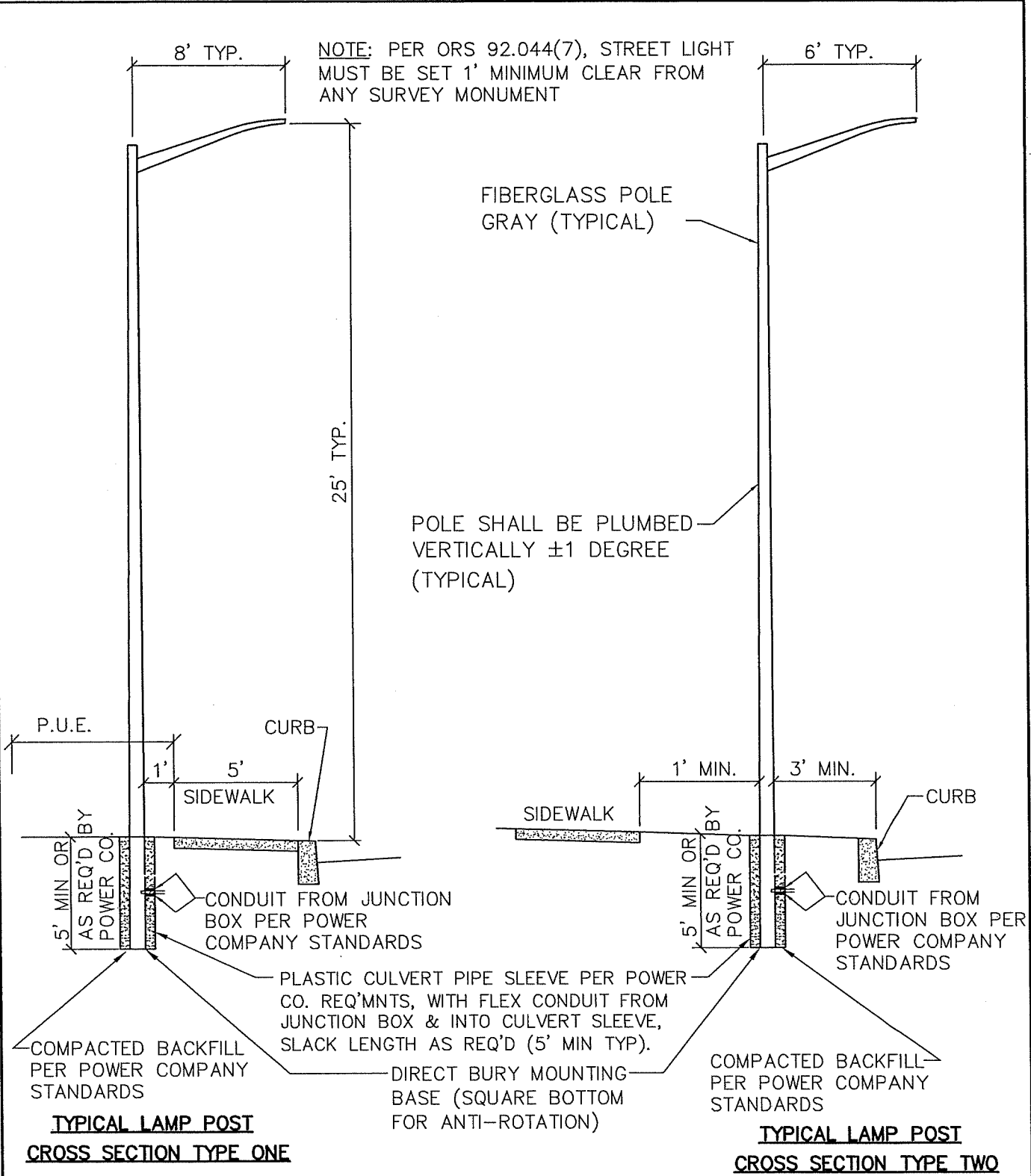

NOTE: PER ORS 92.044(7), STREET LIGHT MUST BE SET 1' MINIMUM CLEAR FROM ANY SURVEY MONUMENT

**TYPICAL LAMP POST
CROSS SECTION TYPE ONE**

**TYPICAL LAMP POST
CROSS SECTION TYPE TWO**

NOTES:

1. CONTRACTOR TO COORDINATE W/LOCAL POWER COMPANY FOR MATERIALS AND WORKMANSHIP REQUIREMENTS.
2. UNLESS OTHERWISE SHOWN ON DRAWINGS OR REQUIRED BY CITY, PROVIDE CITY APPROVED COBRAHEAD LED FIXTURE EQUIVALENT TO 100 WATT HPS.
3. PUBLIC STREET LIGHTS TO BE INSTALLED UNDER TARIFF OPTION A (OWNED & MAINTAINED BY UTILITY).

LAST REVISION DATE: JAN 2023	
TYPICAL STREET LAMP POST	
(NTS)	
AUMSVILLE, OR	DETAIL NO. 230

CULVERT SPECS FIBERGLASS STREETLIGHTS

HOLES TO BE COVERED PER OSHA REQUIREMENTS

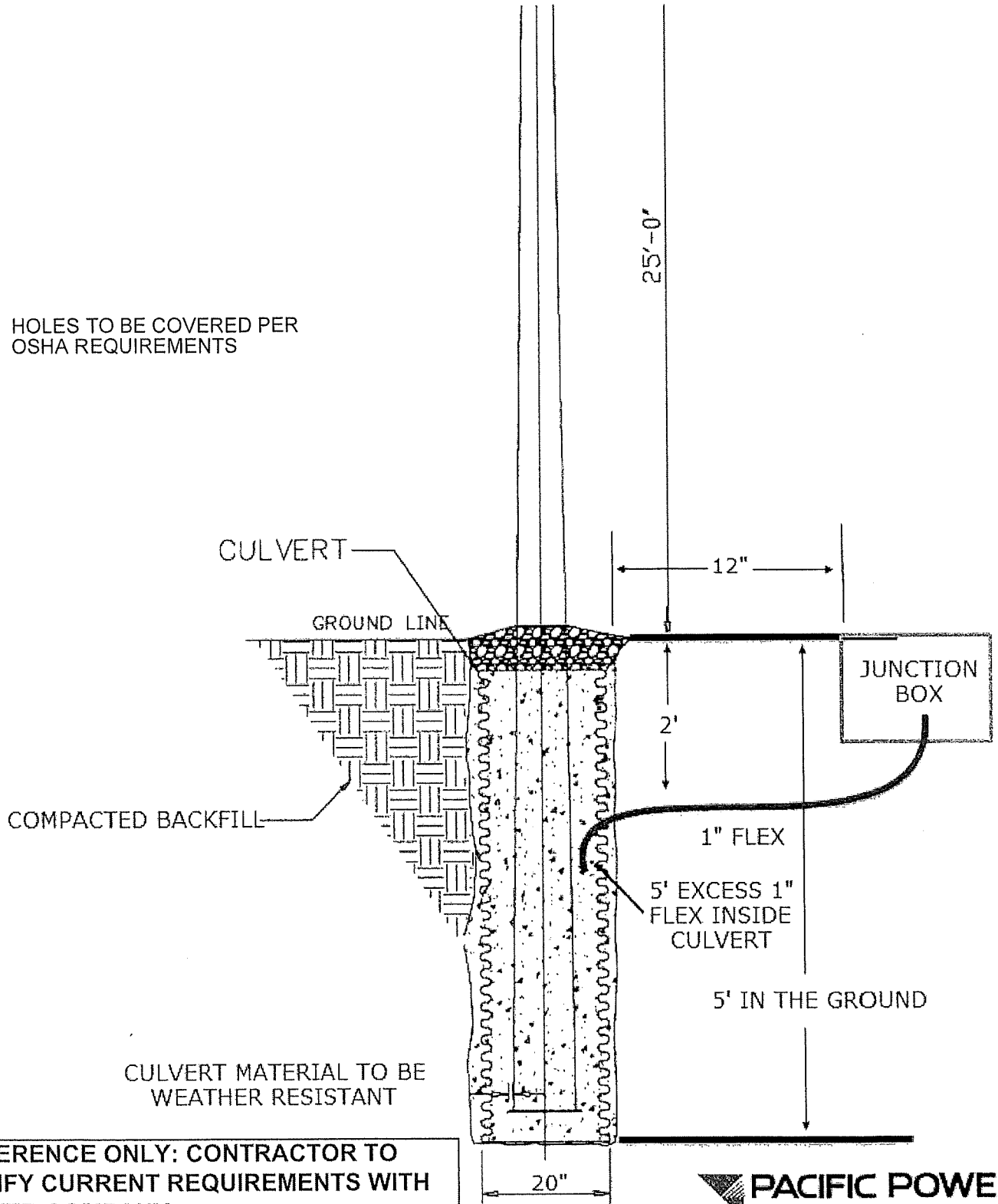

REFERENCE ONLY: CONTRACTOR TO VERIFY CURRENT REQUIREMENTS WITH POWER COMPANY

SIGN TEXT STANDARDS: PROVIDE SIGN TEXT AS FOLLOWS:

- 6" HIGH CHARACTERS FOR UPPER CASE,
- 5" HIGH CHARACTERS FOR LOWER CASE,
- 5" HIGH 1ST LETTER FOR TITLE (Rd/St/Ave/Ln/Ct/Blvd/etc).

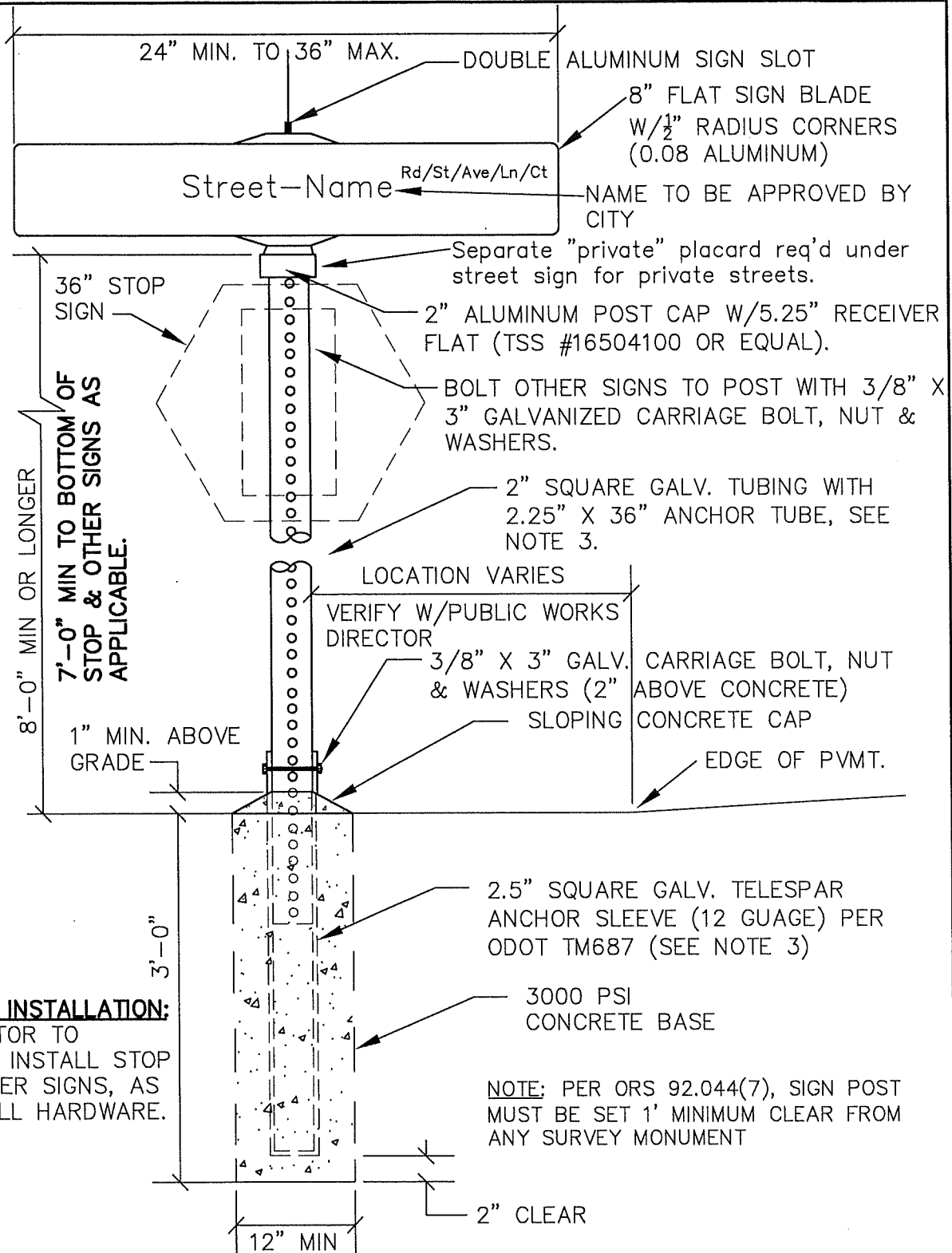

7'-0" MIN TO BOTTOM OF STOP & OTHER SIGNS AS APPLICABLE.

POST/SIGN INSTALLATION:

- CONTRACTOR TO PROVIDE & INSTALL STOP & ALL OTHER SIGNS, AS WELL AS ALL HARDWARE.

NOTE: PER ORS 92.044(7), SIGN POST MUST BE SET 1' MINIMUM CLEAR FROM ANY SURVEY MONUMENT

NOTES:

1. ALL RECONSTRUCTED & NEWLY PLATTED STREETS TO BE SIGNED IN ACCORDANCE WITH ODOT STANDARDS.
2. SIGN PANEL TO BE ALUMINUM PER OSSC 02910, AND ALL SIGNS SHALL CONFORM TO OREGON MUTCD.
3. SIGN POSTS & SLEEVES TO HAVE 7/16" DIAMETER HOLES ON 1" HOLE CENTERS.
4. PROVIDE STOP BARS AT ALL STOP SIGNS (12' TYP LENGTH EACH VEHICLE LANE), BEHIND PEDESTRIAN CROSSING AT LOCATION ACCEPTABLE TO PUBLIC WORKS (SEE NOTES FOR TYPE OF MARKING).

LAST REVISION DATE: JULY 2021	
SIGN POST WITH TELESPAR BASE & ANCHOR (ALL INTERSECTIONS) (NTS)	
AUMSVILLE, OR	DETAIL NO. 232

OFF-STREET PARKING DIMENSIONS

COMPACT SPACES ARE NOT ALLOWED OUTRIGHT BY CITY CODE, UNLESS SPECIFICALLY APPROVED THROUGH THE SITE DEVELOPMENT REVIEW LAND USE APPROVAL PROCESS.

IF APPROVED, STALLS WITHIN EACH PARKING LOT/PARKING FACILITY
MAY BE DISTRIBUTED AS FOLLOWS: 60% STANDARD SPACES,
40% MAXIMUM COMPACT SPACES.

ALL COMPACT SPACES SHALL BE PERMANENTLY LABELED.

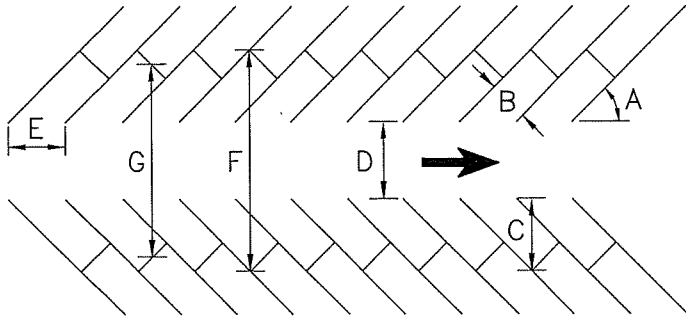

- A- PARKING ANGLE
- B- STALL WIDTH
- C- STALL TO CURB DEPTH
- D- DRIVE AISLE WIDTH BETWEEN STALL LINES (SEE NOTE 1&2)
- E- STALL WIDTH PARALLEL TO AISLE
- F- MODULE WIDTH (FRONT OF STALL TO FRONT OF STALL)
- G- MODULE WIDTH (FRONT OF STALL TO FRONT OF STALL AT BUMPER MIDPOINT)

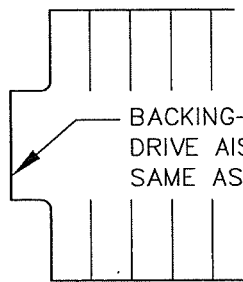

BACKING-POCKET FOR HEAD-IN PARKING WITHOUT DRIVE AISLE EXIT (MIN BACKING-POCKET WIDTH IS SAME AS WIDTH FOR STANDARD PARKING STALL).

OFF-STREET PARKING MATRIX

MINIMUM PARKING SPACE AND AISLE DIMENSIONS (FT)
ONE WAY TRAFFIC FLOW

COMPACT (9' x 16.5', WHERE ALLOWED)							STANDARD (10' x 20')					
A	B	C	D	E	F	G	B	C	D	E	F	G
0°	8.0	8.0	12.0	19.0	28.0	—	8.0	8.0	12.0	22.0	28.0	—
30°	9.0	15.6	12.0	18.0	43.2	35.4	10.0	17.7	12.0	20.0	47.5	38.8
45°	9.0	17.5	13.0	12.7	48.0	42.0	10.0	20.15	13.0	14.1	53.3	46.2
60°	9.0	18.2	18.0	10.4	54.5	50.0	10.0	21.25	18.0	11.6	60.5	55.5
70°	9.0	18.0	19.0	9.6	55.0	51.9	10.0	21.2	19.0	10.6	61.3	57.9
90°	9.0	16.5	24.0	9.0	57.0	57.0	10.0	20.0	24.0	10.0	64.0	64.0

NOTES:

1. WHERE PARKING LOT DRIVE AISLE IS A FIRE LANE, WIDTHS SHALL CONFORM WITH THE OREGON FIRE CODE (OFC) MINIMUMS OF 20 FEET IN ALL CASES (26 FOOT MINIMUM WIDTH, 20 FEET EACH WAY FROM FIRE HYDRANTS), PER OFC 503.2.1 & D103.1.
2. DRIVE AISLE WIDTH "D" IS REQUIRED FOR DRIVING / BACKING / TURNING MOVEMENTS ON BOTH SINGLE LOADED AND DOUBLE LOADED DRIVE AISLES.
3. SEE PWDS 3.28.1 FOR ALLOWABLE STANDARD PARKING SPACE LENGTH REDUCTION WITH SIDEWALKS 6' OR WIDER TO ACCOMODATE BUMPER OVERHANG. LENGTH OF COMPACT SPACES NOT TO BE REDUCED.
4. NUMBER & LOCATION OF ACCESSIBLE PARKING SPACES FOR EACH PARKING LOT/PARKING FACILITY SHALL BE PROVIDED PER OSSC 1106.

LAST REVISION DATE: JULY 2022	<small>COPYRIGHT 1996 WESTECH ENGINEERING, INC.</small>
OFFSTREET PARKING DIMENSIONS ONE WAY TRAFFIC FLOW (NTS)	
AUMSVILLE, OR	DETAIL NO. 235

OFF-STREET PARKING DIMENSIONS

COMPACT SPACES ARE NOT ALLOWED OUTRIGHT BY CITY CODE, UNLESS SPECIFICALLY APPROVED THROUGH THE SITE DEVELOPMENT REVIEW LAND USE APPROVAL PROCESS.

IF APPROVED, STALLS WITHIN EACH PARKING LOT/PARKING FACILITY MAY BE DISTRIBUTED AS FOLLOWS: 60% STANDARD SPACES, 40% MAXIMUM COMPACT SPACES.

ALL COMPACT SPACES SHALL BE PERMANENTLY LABELED.

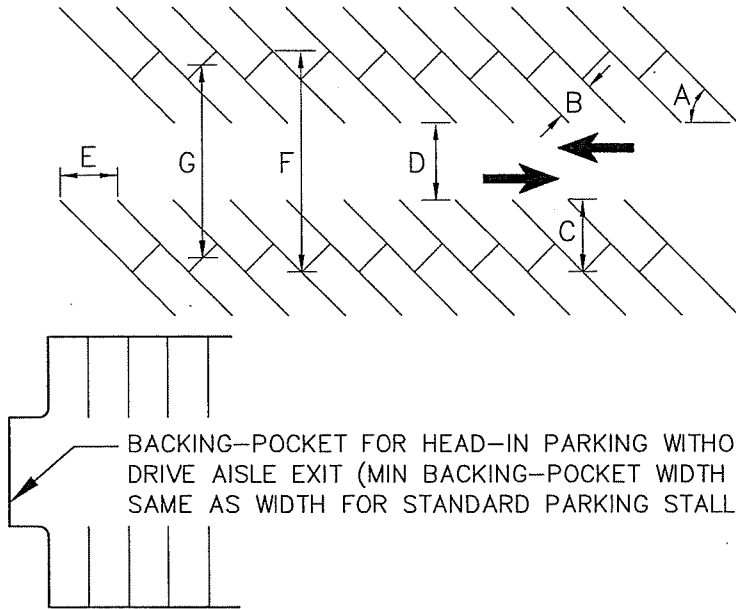

- A— PARKING ANGLE
- B— STALL WIDTH
- C— STALL TO CURB DEPTH
- D— DRIVE AISLE WIDTH BETWEEN STALL LINES (SEE NOTE 1&2)
- E— STALL WIDTH PARALLEL TO AISLE
- F— MODULE WIDTH (FRONT OF STALL TO FRONT OF STALL)
- G— MODULE WIDTH (FRONT OF STALL TO FRONT OF STALL AT BUMPER MIDPOINT)

OFF-STREET PARKING MATRIX

MINIMUM PARKING SPACE AND AISLE DIMENSIONS (FT)
ONE WAY TRAFFIC FLOW

COMPACT (9' x 16.5', WHERE ALLOWED)							STANDARD (10' x 20')					
A	B	C	D	E	F	G	B	C	D	E	F	G
0°	8.0	8.0	24.0	19.0	40.0	—	8.0	8.0	24.0	22.0	40.0	—
30°	9.0	15.6	24.0	18.0	55.2	47.4	10.0	17.7	24.0	20.0	59.5	50.8
45°	9.0	17.5	24.0	12.7	59.0	52.6	10.0	20.15	24.0	14.1	64.3	57.2
60°	9.0	18.2	24.0	10.4	60.5	56.0	10.0	21.25	24.0	11.6	66.5	61.5
70°	9.0	18.0	24.0	9.6	60.0	56.9	10.0	21.2	24.0	10.6	66.3	62.9
90°	9.0	16.5	24.0	9.0	57.0	57.0	10.0	20.0	24.0	10.0	64.0	64.0

NOTES:

1. WHERE PARKING LOT DRIVE AISLE IS A FIRE LANE, WIDTHS SHALL CONFORM WITH THE OREGON FIRE CODE (OFC) MINIMUMS OF 20 FEET IN ALL CASES (26 FOOT MINIMUM WIDTH, 20 FEET EACH WAY FROM FIRE HYDRANTS), PER OFC 503.2.1 & D103.1.
2. DRIVE AISLE WIDTH "D" IS REQUIRED FOR DRIVING / BACKING / TURNING MOVEMENTS ON BOTH SINGLE LOADED AND DOUBLE LOADED DRIVE AISLES.
3. SEE PWDS 3.28.1 FOR ALLOWABLE STANDARD PARKING SPACE LENGTH REDUCTION WITH SIDEWALKS 6' OR WIDER TO ACCOMODATE BUMPER OVERHANG. LENGTH OF COMPACT SPACES NOT TO BE REDUCED.
4. NUMBER & LOCATION OF ACCESSIBLE PARKING SPACES FOR EACH PARKING LOT/PARKING FACILITY SHALL BE PROVIDED PER OSSC 1106.

LAST REVISION DATE: JULY 2022	<small>COPYRIGHT 1996 WESTECH ENGINEERING, INC.</small>
OFFSTREET PARKING DIMENSIONS TWO WAY TRAFFIC FLOW (NTS)	
AUMSVILLE, OR	DETAIL NO. 236

RESERVED
PARKING



VAN-ACCESSIBLE

WHEELCHAIR USER
ONLY

REFERENCE NOTE: ACCESSIBLE PARKING SPACES, ACCESS ROUTES, SIGNS, ETC. TO FULLY COMPLY WITH REQUIREMENTS OF THE **OREGON TRANSPORTATION COMMISSION – STANDARDS FOR ACCESSIBLE PARKING PLACES (OTC-SAPP), AUGUST 2018** (SEE PWDS APP F).

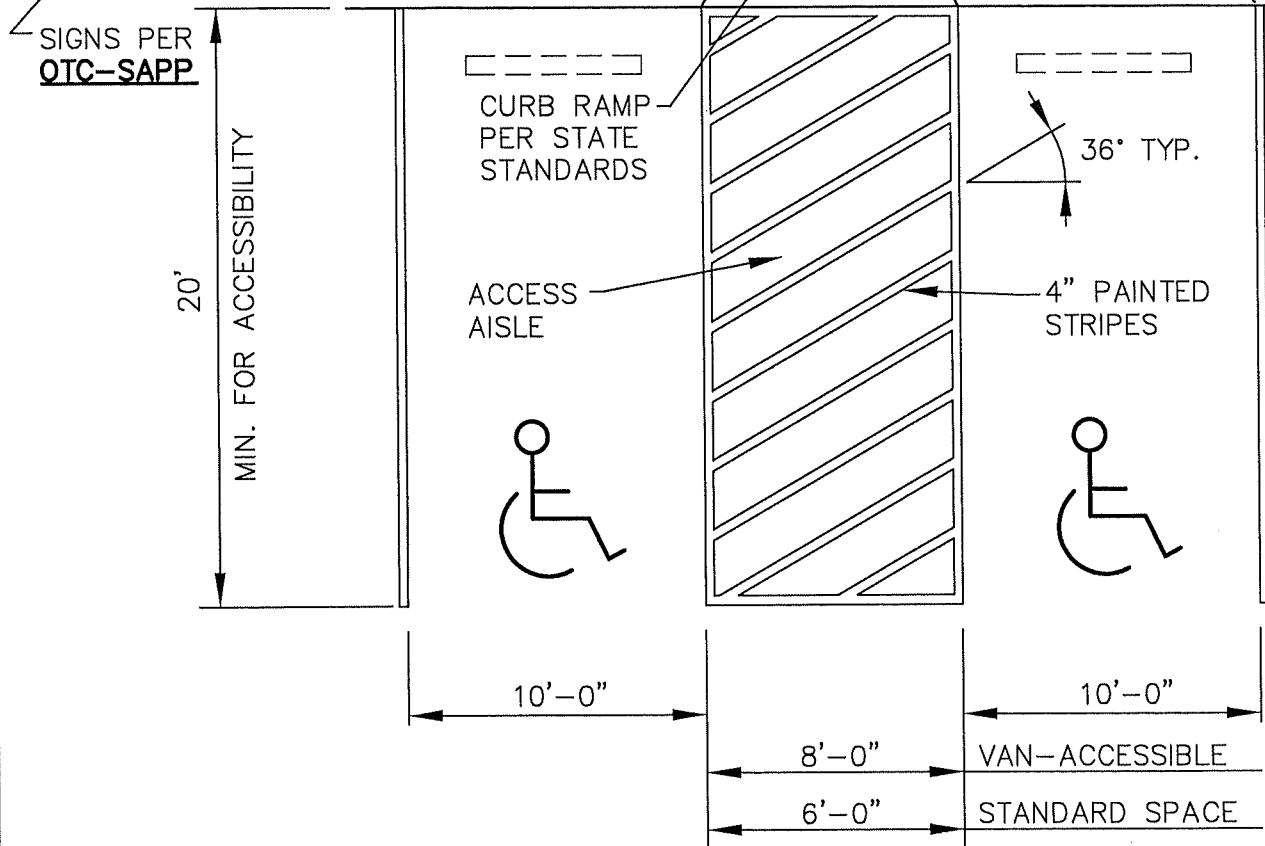
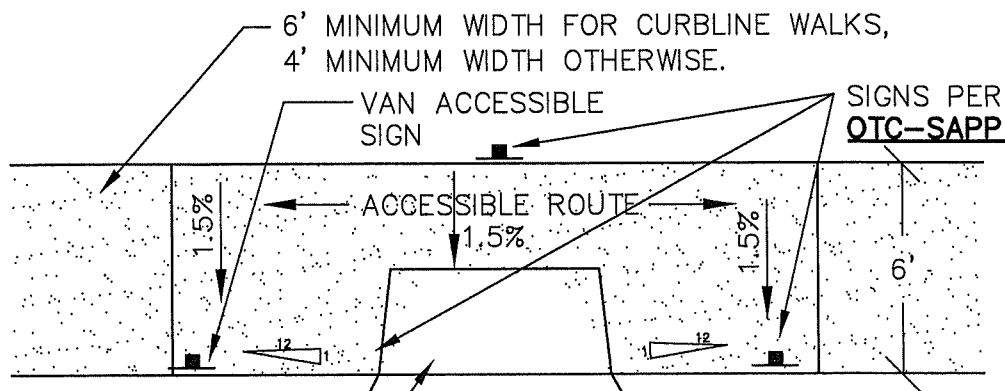

DOUBLE ACCESSIBLE PARKING SPACE

NOTES:

1. ONE ACCESSIBLE PARKING SPACE MUST BE DESIGNATED "VAN-ACCESSIBLE", THE OTHER SPACE CAN BE EITHER "VAN-ACCESSIBLE" OR STANDARD PARKING SPACE.
2. VAN-ACCESSIBLE OR WHEELCHAIR ONLY SPACES SHALL HAVE AN ADDITIONAL SIGN MOUNTED BELOW THE STANDARD PARKING SPACE PARKING SIGN.
3. VAN-ACCESSIBLE SPACE CAN BE USED BY ANY VEHICLE WITH A DMV DISABLED PERMIT.
4. MAXIMUM 2% CROSS SLOPE ALLOWED IN PARKING SPACE OR ACCESS AISLE.
5. POST MOUNTED SIGNS SHALL HAVE 7' (±3") CLEARANCE FROM SIGN BOTTOM TO GROUND.

LAST REVISION DATE: FEB 2022	
DOUBLE ACCESSIBLE PARKING SPACE	
(NTS)	
AUMSVILLE, OR	DETAIL NO. 237

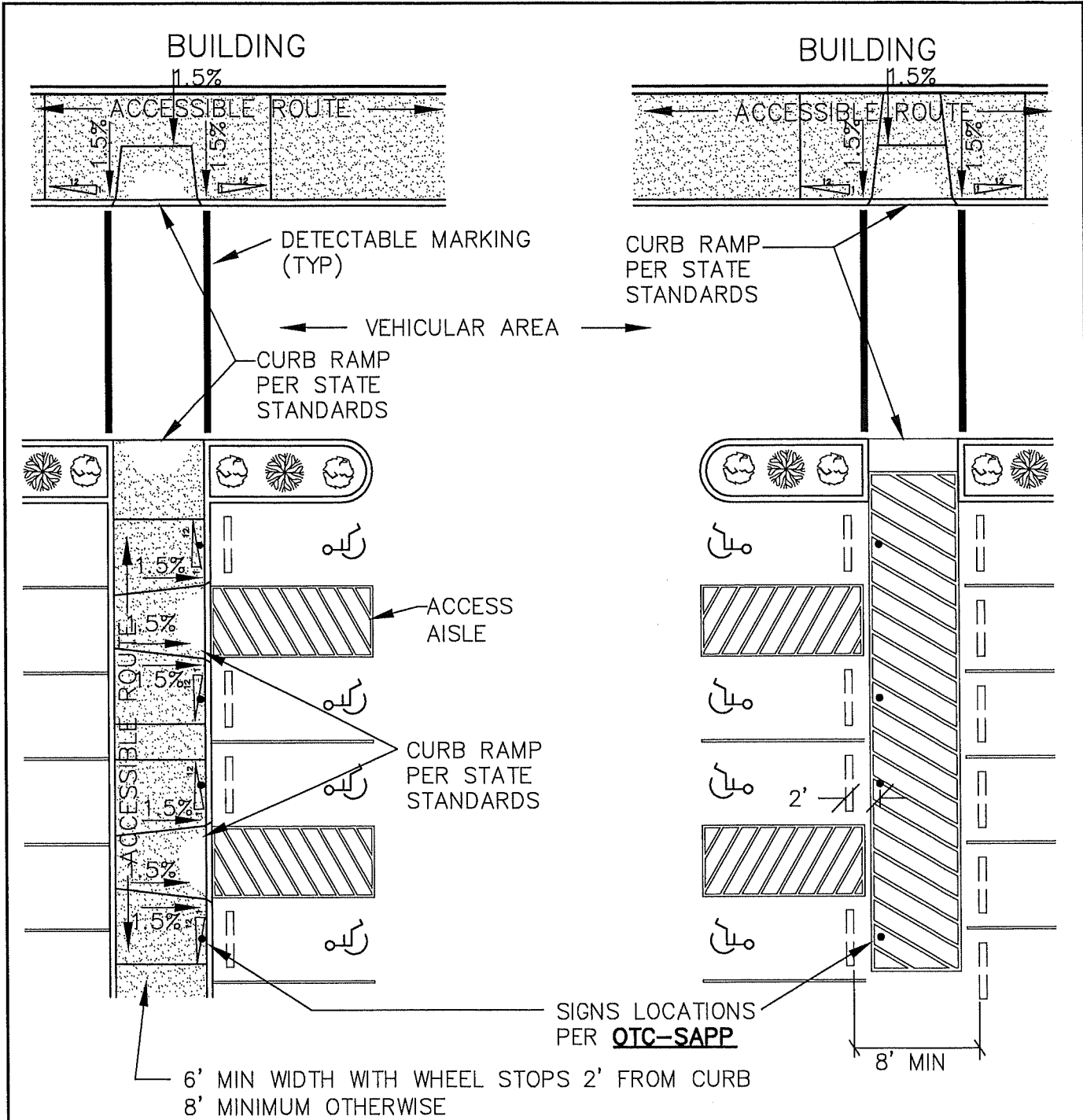

ACCESSIBLE PARKING PLAN ①

ACCESSIBLE PARKING PLAN ②

NOTES:

- 1. **REFERENCE NOTE:** ACCESSIBLE PARKING SPACES, ACCESS ROUTES, SIGNS, ETC. TO FULLY COMPLY WITH REQUIREMENTS OF THE **OREGON TRANSPORTATION COMMISSION – STANDARDS FOR ACCESSIBLE PARKING PLACES (OTC-SAPP), AUGUST 2018** (SEE PWDS APP F).
- 2. SEE DETAIL 2370 FOR ACCESSIBLE PARKING SPACE LAYOUT.

LAST REVISION DATE: SEPT 2021	
ACCESSIBLE ROUTES AND CROSSINGS IN VEHICULAR AREAS (NTS)	
AUMSVILLE, OR	DETAIL NO. 238

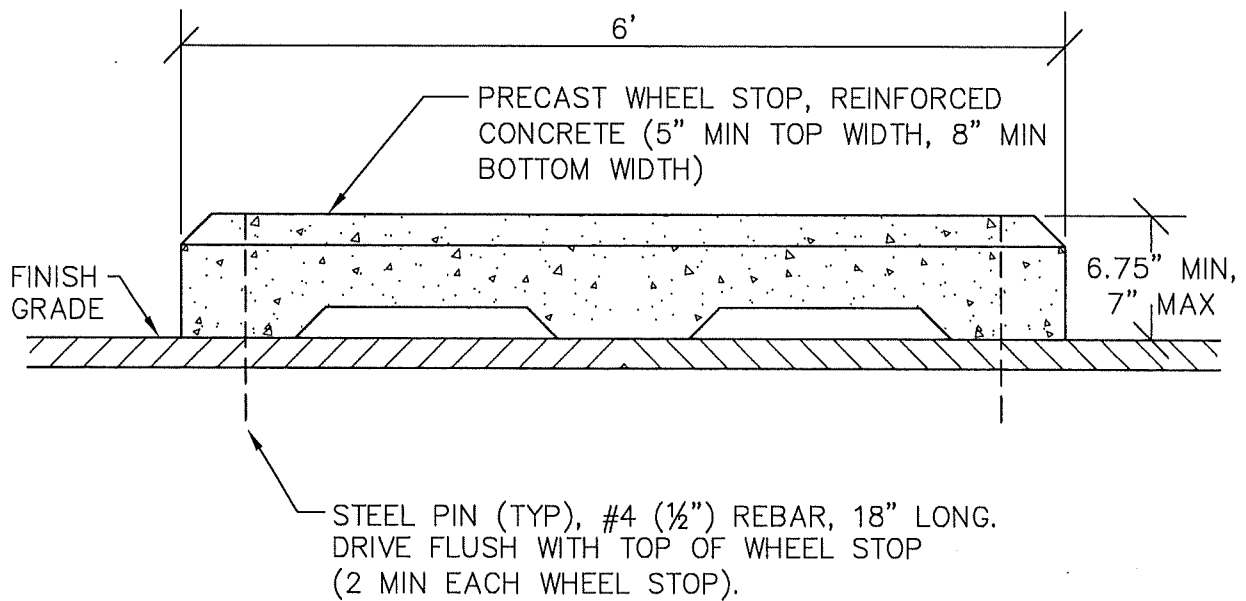

SECTION

NTS

NOTES:

1. SEE DRAWINGS FOR LOCATION & NUMBER OF WHEEL STOPS, INCLUDING DIMENSION FROM CURB, EDGE OF PAVEMENT OR BUILDING AS APPLICABLE.
2. UNLESS OTHERWISE SPECIFIED OR SHOWN ON SITE PLAN, SET WHEEL STOPS 2 FEET FROM FACE OF CURB OR EDGE OF PAVEMENT, MEASURED FROM THE FACE OF THE WHEEL STOP (VEHICLE SIDE) TO FACE OF CURB (OR EDGE OF PAVEMENT). SET BACK FROM PROPERTY LINES PER CITY STANDARDS (3' MIN). MIN SETBACK FROM BUILDINGS AS SHOWN ON DWGS.
3. FOR USE ON HEAD-IN PARKING WITHOUT FULL HEIGHT CURBS, OR WHERE A SIDEWALK ALONG HEAD-IN PARKING IS LESS THAN 6 FEET WIDE.

LAST REVISION DATE: FEB 2021	JO #
PRECAST WHEELSTOP DETAIL	
(NTS)	
AUMSVILLE, OR	DETAIL NO. 239

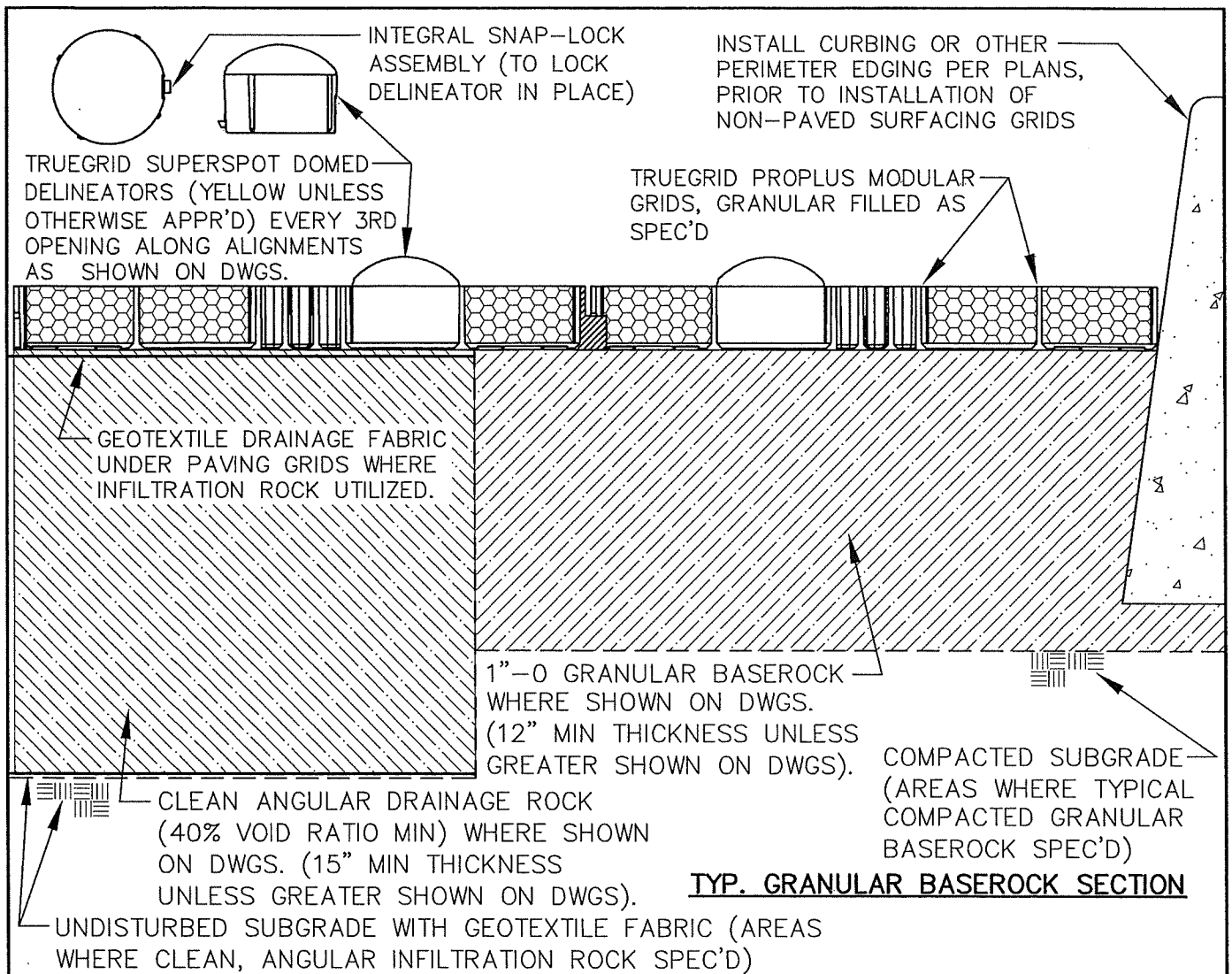

NOTES:

1. UNLESS OTHERWISE SHOWN ON APPROVED DRAWINGS, BASEROCK UNDER PAVING GRIDS SHALL BE 1"-0 GRANULAR BASEROCK, COMPACTED TO 95% OPTIMUM PER AASHTO T-180. TYPICAL MODULAR GRID FILL SHALL BE 3/4"-0 GRANULAR BASEROCK.
2. WHERE INFILTRATION CONFIGURATION IS SHOWN ON APPROVED DRAWINGS, DRAINAGE STONE UNDER PAVING GRIDS SHALL BE CLEAN, CRUSHED, ANGULAR QUARRY STONE WITH 3/4"-2" GRADATION SIZE. MODULAR GRID FILL SHALL BE 1/2" CLEAN ANGULAR STONE.
3. A PERFORATED PIPE TIED TO A PIPED OVERFLOW SHALL BE PROVIDED FOR ANY INFILTRATION SYSTEM WHICH COULD OTHERWISE OVERFLOW ONTO ADJACENT PRIVATE PROPERTY OR ACROSS SIDEWALKS (PIPE NOT SHOWN IN THIS DETAIL).
4. WHEEL STOPS FOR INFILTRATION CONFIGURATION (WHERE PROVIDED) SHALL BE PINNED IN PLACE WITH #4 REBAR, LENGTH AS REQUIRED TO EXTEND 24" MINIMUM INTO THE SUBGRADE BELOW THE DRAINAGE ROCK.
6. **CURBS & OTHER ADJACENT HARD SURFACES SHALL BE INSTALLED BEFORE INSTALLATION OF MODULAR SURFACING GRIDS. THE CONTRACTOR SHALL VERIFY THAT THE PROPOSED GRID GRADE ELEVATIONS MATCH OTHER SURFACES, BASED ON THE SLOPES SHOWN ON THE DRAWINGS AND ANY SPECIFIED CURB EXPOSURE. MODULAR GRIDS SHALL BE SET FLUSH W/ADJACENT HARD SURFACES OR SLIGHTLY RECESSED (1/4" MAX). ANY DISCREPANCIES SHALL BE REPORTED TO THE ENGINEER PRIOR TO PLACEMENT OR CONSTRUCTION.**

LAST REVISION DATE: NOV 2022	
TRUEGRID PROPLUS INDUSTRIAL GRADE MODULAR NON-PAVED SURFACE SYSTEM (NTS)	
AUMSVILLE, OR	DETAIL NO. 240

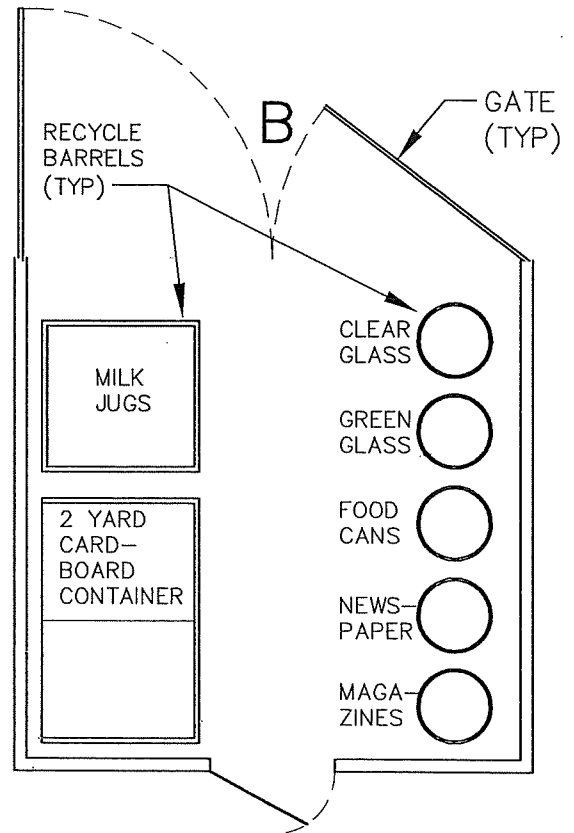
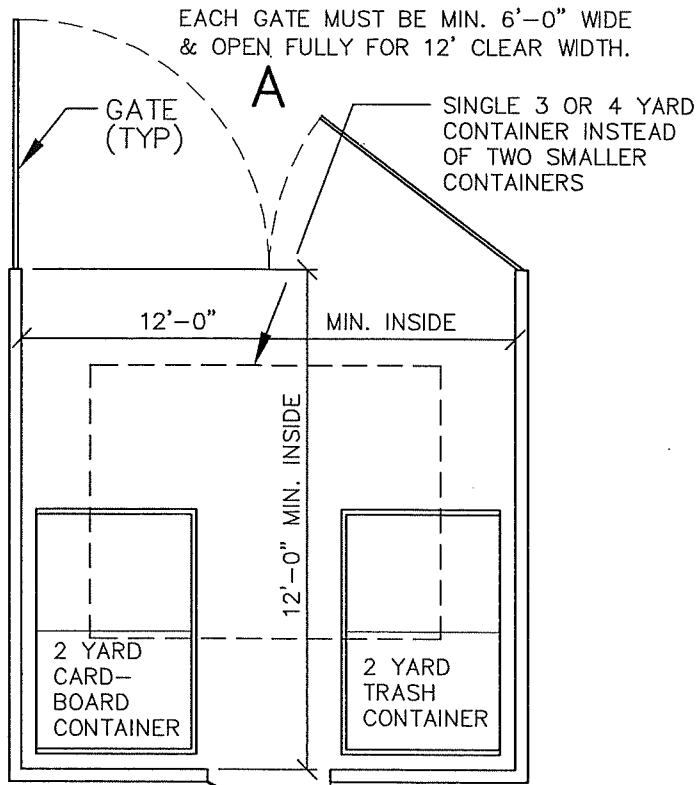

3'-0" GATE OR DOOR REQ'D. AT REAR OF ENCLOSURE (TYP.)

ENCLOSURES SHALL BE LOCATED OUTSIDE OF THE PUBLIC R/W (UNLESS OTHERWISE APPROVED IN WRITING BY THE CITY).

TRASH ENCLOSURE**

RECYCLE ENCLOSURE**

**ENCLOSURES SHOWN ARE TYPICAL EXAMPLES UNLESS ALTERNATE CONFIGURATION IS APPROVED BY TRASH/RECYCLING FRANCHISEE AND CITY PLANNER.

NOTES:

1. GATES:
 - (a) ALL GATES MUST ATTACH AT THE END OF OF THE WALLS TO PROVIDE A MINIMUM OF 12' CLEAR WORKING SPACE WHEN OPEN.
 - (b) TO SERVICE THE ENCLOSURE, THE GATES MUST BE ABLE TO BE PINNED IN MUST BE ABLE TO BE PINNED IN THE FULL OPEN POSITION.
 - (c) GATES MUST OPEN FROM OUTSIDE THE ENCLOSURE.
2. FOR 5 OR 6 YARD CONTAINERS THE ENCLOSURE DEPTH MUST BE 15'.
3. WHERE REQ'D. (I.E. RESTAURANTS), GREASE BARRELS MUST BE SEPARATE FROM TRASH AND RECYCLING ENCLOSURES.
4. ROOFS OR OVERHANGS SHALL HAVE 15' OF OVERHEAD CLEARANCE.
5. IF RECYCLING IS NOT INCLUDED, AREA (A) CAN PROVIDE SERVICE FOR TRASH AND CARDBOARD FOR CONTAINER SIZES OF 1 TO 2 YARDS. IF A 3 YARD OR LARGER TRASH CONTAINER IS NEEDED, AN ADDITIONAL 12' X 12' SPACE WILL BE NECESSARY FOR CARDBOARD CONTAINER SERVICE.
6. CONCRETE PADS REQUIRED FOR ALL ENCLOSURES. WALLS, GATE & DOOR MATERIALS & HEIGHT PER CITY STANDARDS BASED ON SCREENING REQUIREMENTS.
7. A 1 YD. CONTAINER WILL HOLD APPROXIMATELY THE SAME AS 6 TRASH CANS (32 GAL SIZE). USE 6 TIMES THE CONTAINER SIZE IN YARDS TO ESTIMATE A CONTAINER CAPACITY. FOR EXAMPLE, A 3 YD. CONTAINER WILL HOLD APPROX THE SAME AMOUNT AS 18 TRASH CANS (32 GAL SIZE).

LAST REVISION DATE:

FEB 2021

TYPICAL TRASH AND RECYCLING ENCLOSURE

(NTS)

DETAIL NO.

AUMSVILLE, OR

250

TRENCH COMPACTION: CLASS 1 GRANULAR BACKFILL - 92% OPTIMUM PER AASHTO T-180 (MODIFIED PROCTOR)
 CLASS 3 NATIVE BACKFILL - 85% OPTIMUM PER AASHTO T-180

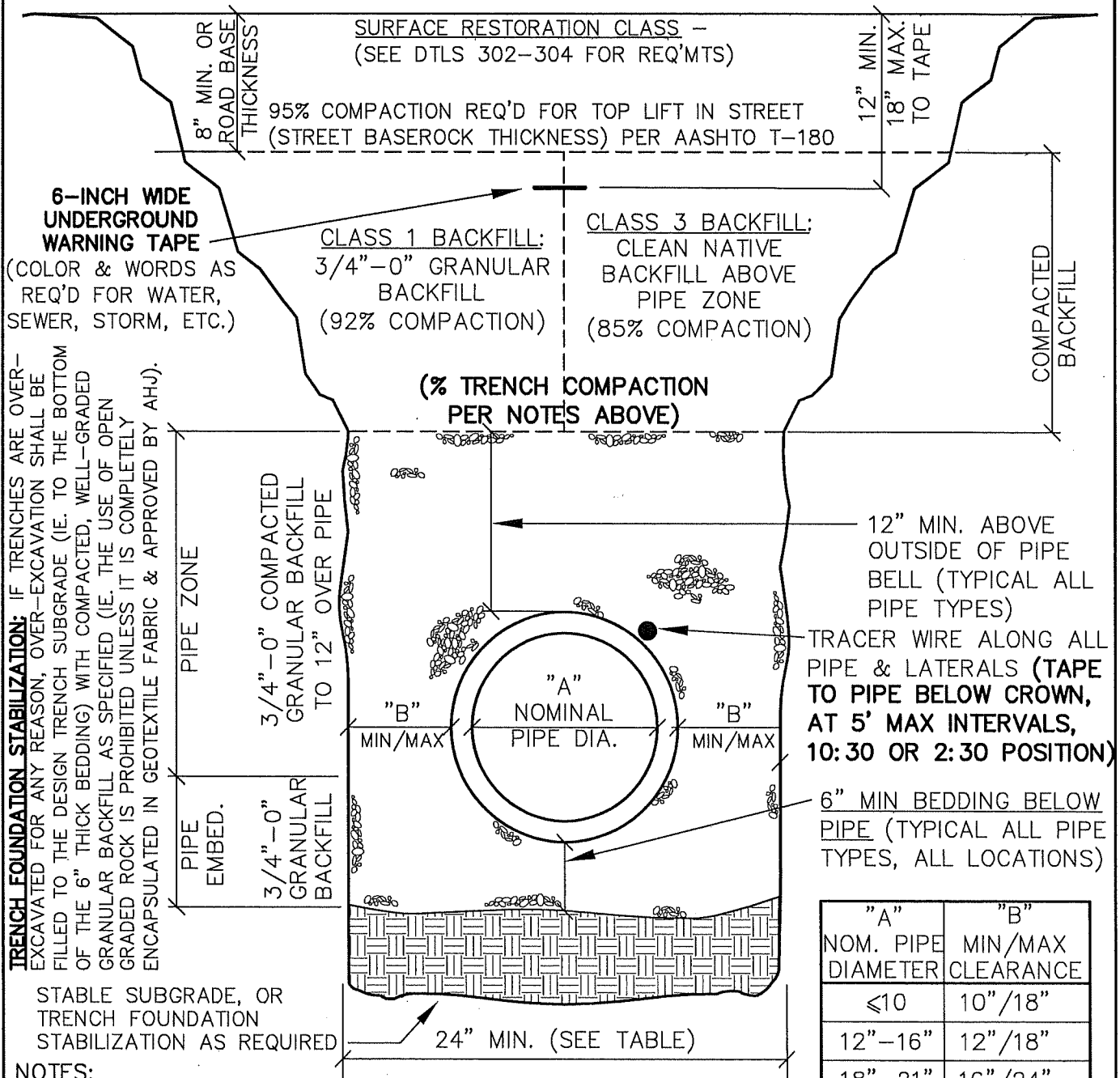

TRENCH FOUNDATION STABILIZATION: IF TRENCHES ARE OVER-EXCAVATED FOR ANY REASON, OVER-EXCAVATION SHALL BE FILLED TO THE DESIGN TRENCH SUBGRADE (I.E. TO THE BOTTOM OF THE 6" THICK BEDDING) WITH COMPACTED, WELL-GRADED GRANULAR BACKFILL AS SPECIFIED (I.E. THE USE OF OPEN GRADED ROCK IS PROHIBITED UNLESS IT IS COMPLETELY ENCAPSULATED IN GEOTEXTILE FABRIC & APPROVED BY AHJ).

STABLE SUBGRADE, OR TRENCH FOUNDATION STABILIZATION AS REQUIRED

NOTES:

1. CLASS 1 REQ'D. UNDER ALL EXIST. OR FUTURE IMPROVED AREAS INCLUDING SIDEWALKS.
2. WHERE NEW PIPING IS IN SAME ALIGNMENT AS EXISTING PIPING, THE PIPE EMBEDMENT SHALL EXTEND TO A MIN. OF 6" BELOW THE NEW PIPING OR 6" BELOW EXISTING PIPING, WHICHEVER IS DEEPER.
3. FOR FLEXIBLE PIPE, BOTTOM OF TRENCH SHORING SHALL BE ABOVE PIPE SPRINGLINE PRIOR TO COMPACTING BACKFILL BELOW THE PIPE SPRINGLINE AND UNDER THE PIPE HAUNCHES.
4. MINIMUM CLEARANCES SHOWN ("B") ASSUMES STANDARD 6" WALL TRENCH BOXES SET ON TRENCH BOTTOM, AND REPRESENTS WIDTH REQUIRED TO CONSOLIDATE GRANULAR MATERIAL UNDER PIPE HAUNCHES (TO AVOID LOSS OF SIDE SUPPORT WHEN TRENCH BOX IS MOVED OR PULLED FORWARD). TRENCH WIDTH REDUCTION REQUIRES PRIOR APPROVAL BASED ON ACTUAL TRENCH SHORING PROPOSED.

"A" NOM. PIPE DIAMETER	"B" MIN/MAX CLEARANCE
≤10	10"/18"
12"-16"	12"/18"
18"-21"	16"/24"
24"-30"	18"/30"
>30"	24"/36"

(SEE NOTE 4)

LAST REVISION DATE: FEB 2021	
TRENCH BACKFILL, BEDDING, AND PIPE ZONE	
(NTS)	
AUMSVILLE, OR	DETAIL NO. 301

PLACE 4" MIN. THICKNESS, CL.'C' A.C. IN TWO EQUAL LIFTS, OR THICKNESS OF REMOVED PAVEMENT, WHICHEVER IS GREATER, TO 91% OPT. DENSITY PER RICE STD. METHOD.

SEAL SURFACE OVER JOINT WITH TACK MATERIAL AND SAND (AC PATCH ONLY)

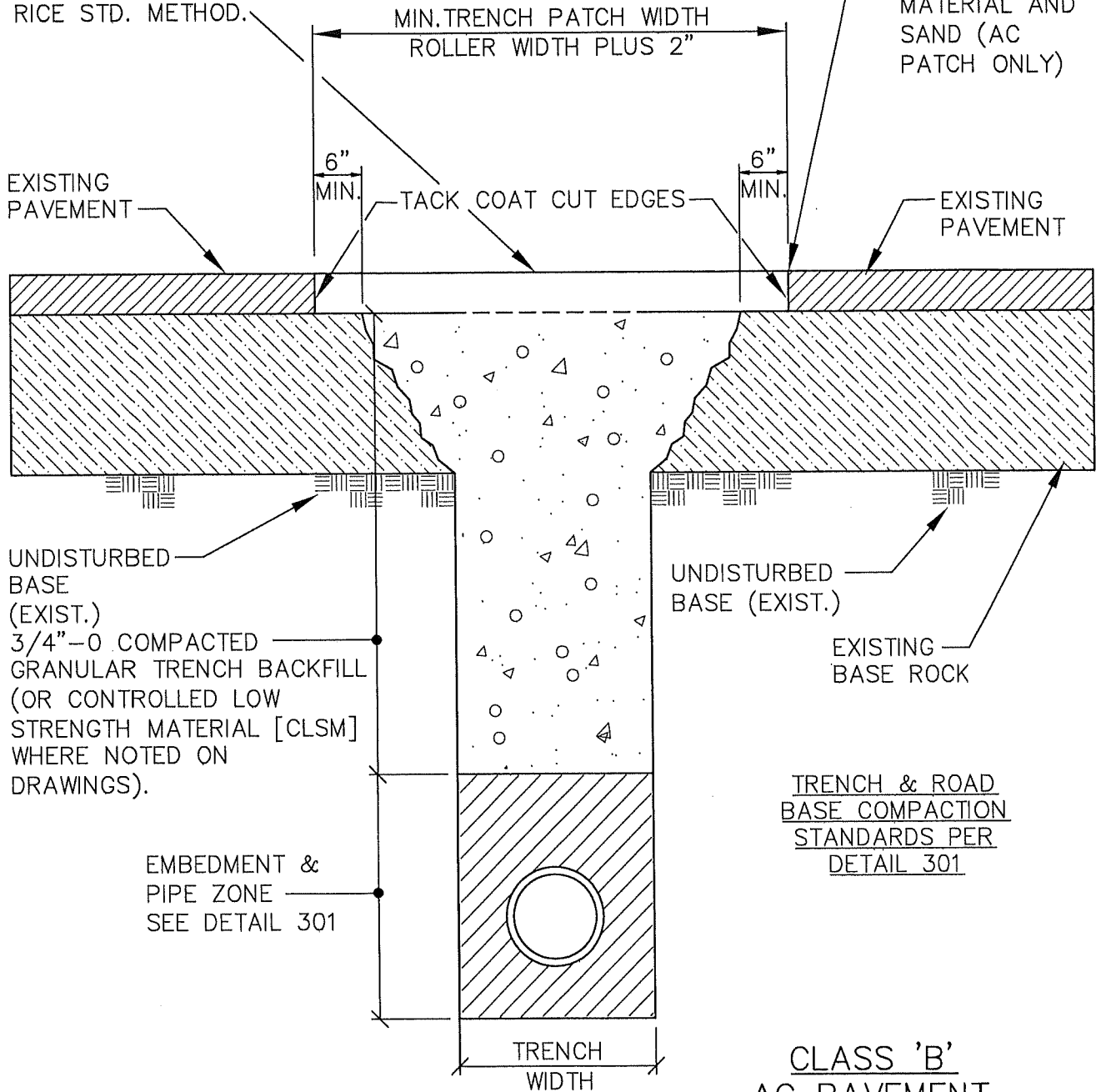

NOTES:

1. ALL EXISTING AC OR PCC PAVEMENT SHALL BE SAWCUT PRIOR TO REPAVING.
2. PCC CONCRETE PAVEMENT SHALL BE REPLACED WITH 3300 PSI PCC TO A MINIMUM THICKNESS OF 6" OR TO THE THICKNESS OF REMOVED CONCRETE, WHICHEVER IS GREATER.
3. FOR PAVED DRIVEWAYS (EXCEPT COMMERCIAL OR INDUSTRIAL) WITH LESS THAN 4" EXISTING AC, PAVEMENT THICKNESS MAY BE REDUCED TO 3" AC IN 2 LIFTS, AND OVERCUT MAY BE REDUCED TO 3" EACH SIDE.

LAST REVISION DATE: FEB 2021	
MINOR OR PRIVATE STREET AND AC DRIVEWAY CUT SURFACE RESTORATION (NTS)	
AUMSVILLE, OR	DETAIL NO. 302

PLACE 4" MIN. THICKNESS, CL. 'C' A.C. IN LIFTS. COMPACT TO 91% OPTIMUM DENSITY PER RICE STD. METHOD. (MATCH EXTG AC THICKNESS)

18" MIN. WIDTH PRE-TACKED PAVING FABRIC (MIRAFI MTK, PETROTAC OR EQUAL), SIDE & END JOINTS.

SEAL SURFACE OVER JOINT WITH TACK MATERIAL AND SAND.

MIN. TRENCH PATCH WIDTH ROLLER WIDTH PLUS 2"

GRIND 24" BENCH INTO EXTG AC PAVEMENT. SEE NOTE 1 BELOW (18" MIN. WIDTH AFTER SAWCUT).

6" MIN. TACK COAT CUT EDGES & GRIND AREAS

EXISTING PAVEMENT

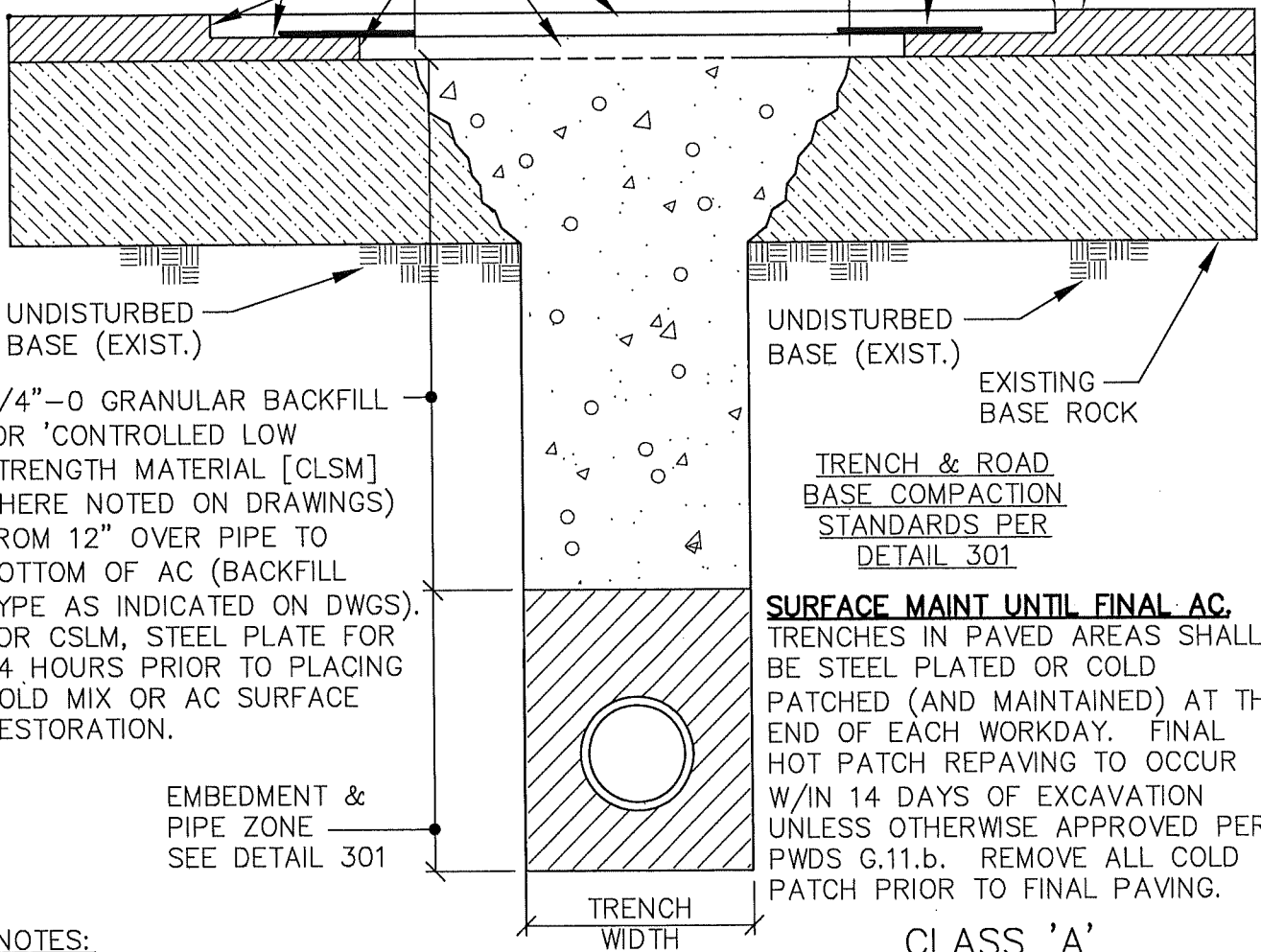

UNDISTURBED BASE (EXIST.)
 3/4"-0 GRANULAR BACKFILL (OR 'CONTROLLED LOW STRENGTH MATERIAL [CLSM] WHERE NOTED ON DRAWINGS) FROM 12" OVER PIPE TO BOTTOM OF AC (BACKFILL TYPE AS INDICATED ON DWGS). FOR CSLM, STEEL PLATE FOR 24 HOURS PRIOR TO PLACING COLD MIX OR AC SURFACE RESTORATION.

UNDISTURBED BASE (EXIST.)
 EXISTING BASE ROCK
 TRENCH & ROAD BASE COMPACTION STANDARDS PER DETAIL 301

SURFACE MAINT UNTIL FINAL AC. TRENCHES IN PAVED AREAS SHALL BE STEEL PLATED OR COLD PATCHED (AND MAINTAINED) AT THE END OF EACH WORKDAY. FINAL HOT PATCH REPAVING TO OCCUR W/IN 14 DAYS OF EXCAVATION UNLESS OTHERWISE APPROVED PER PWDS G.11.b. REMOVE ALL COLD PATCH PRIOR TO FINAL PAVING.

EMBEDMENT & PIPE ZONE SEE DETAIL 301

TRENCH WIDTH

NOTES:

1. FOLLOWING BACKFILL COMPACTION OR CLSM INSTALLATION, GRIND 24" WIDE BENCH IN EXISTING AC ON BOTH SIDES & TRENCH ENDS, 2" DEEP OR HALF THE DEPTH OF EXISTING AC (3" MAX).
2. AFTER GRINDING, SAWCUT ALONG TRENCH SIDES, 6" BACK FROM TRENCH EDGE.
3. BASE LIFT(S). TACK COAT EDGES, INSTALL/COMPACT BASE LIFTS (3" MAX LIFT) TO LEVEL OF BENCH GRIND.
4. FINISH LIFT. INSTALL JOINT SEAL FABRIC, TACK COAT GRIND SURFACES & EDGES, & INSTALL TOP LIFT OF AC. SAND SEAL ALL JOINTS (REMOVE EXCESS SAND AFTER CURE).

CLASS 'A' AC PAVEMENT RESTORATION

LAST REVISION DATE: FEB 2021	
AC STREET CUT SURFACE RESTORATION W/BENCH GRIND (NTS)	
AUMSVILLE, OR	DETAIL NO. 302A

INSTALL TWO 2" LIFTS OF LEVEL 3 1/2-INCH ACP PER ODOT SPECS, **OR MATCH EXISTING PAVEMENT THICKNESS**, WHICHEVER IS GREATER. (3" MAX LIFT THICKNESS).

PLACE (2) 2" LIFTS, LEVEL 3 1/2-INCH ACP PER ODOT SPECS

GRIND THIS AREA 4" DEEP FOR 10 FEET MIN EACH WAY FROM TRENCH EDGE UNLESS OTHERWISE APPROVED OR REQUIRED BY ODOT.

TACK COAT PRIOR TO PAVING & SAND SEAL JOINTS AFTER PAVING.

MIN. TRENCH PATCH WIDTH
TRENCH WIDTH + 2*GRIND WIDTH

EXISTING PAVEMENT

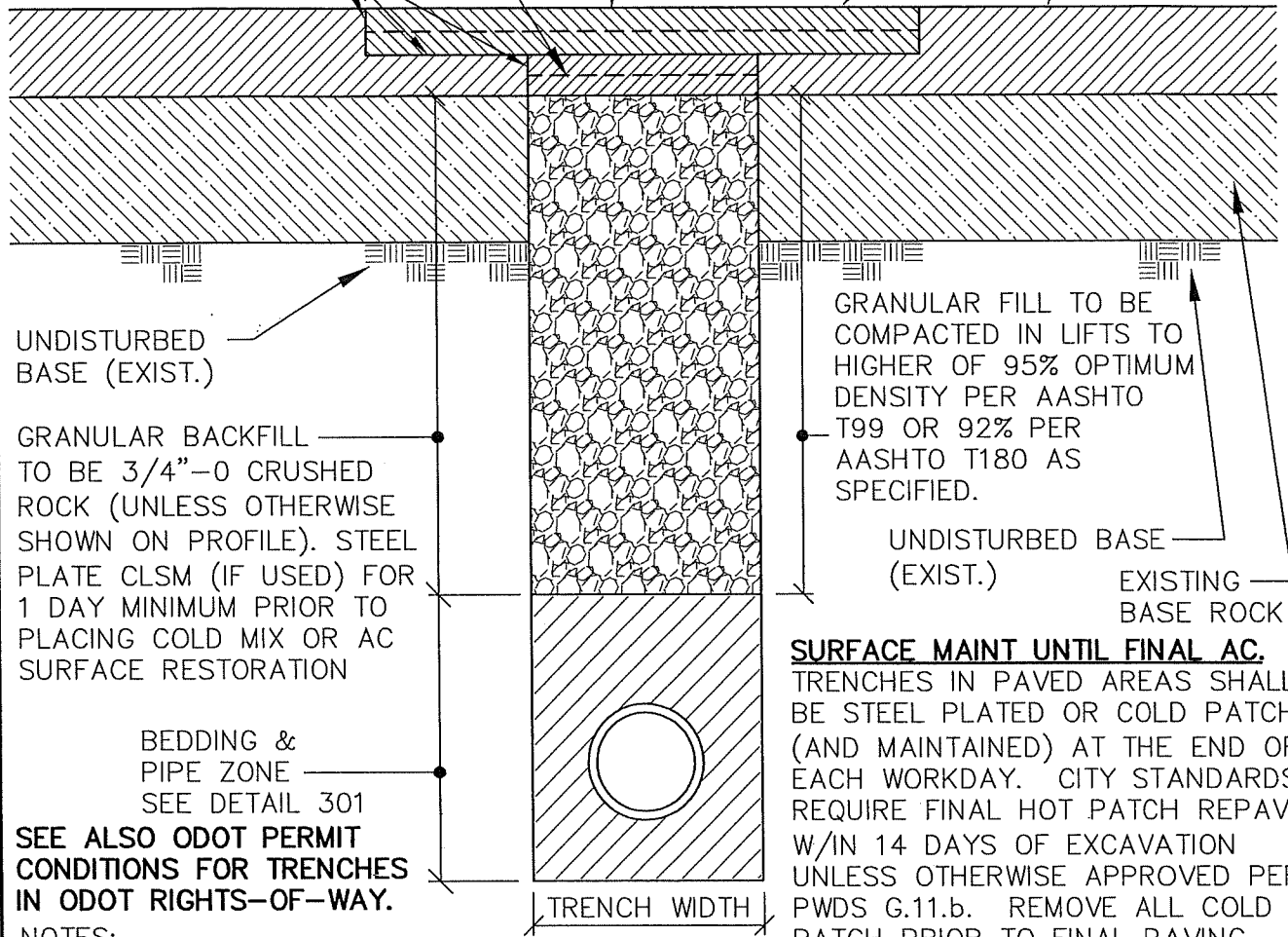

GRANULAR FILL TO BE COMPACTED IN LIFTS TO HIGHER OF 95% OPTIMUM DENSITY PER AASHTO T99 OR 92% PER AASHTO T180 AS SPECIFIED.

UNDISTURBED BASE (EXIST.)

EXISTING BASE ROCK

SURFACE MAINT UNTIL FINAL AC. TRENCHES IN PAVED AREAS SHALL BE STEEL PLATED OR COLD PATCHED (AND MAINTAINED) AT THE END OF EACH WORKDAY. CITY STANDARDS REQUIRE FINAL HOT PATCH REPAVING W/IN 14 DAYS OF EXCAVATION UNLESS OTHERWISE APPROVED PER PWDS G.11.b. REMOVE ALL COLD PATCH PRIOR TO FINAL PAVING.

SEE ALSO ODOT PERMIT CONDITIONS FOR TRENCHES IN ODOT RIGHTS-OF-WAY.

NOTES:

1. COMPACT ALL ACP LIFTS TO 91% OPTIMUM DENSITY PER RICE STANDARD METHOD.
2. ASPHALT EMULSION TACK COAT SHALL BE USED TO SEAL THE ACP TO THE EDGES OF THE EXISTING AC PAVEMENT. ALL AC PAVEMENT CUTS SHALL BE VERTICAL, CLEAN & ASPHALT SAND SEALED ALONG ALL EDGES AFTER INSTALLATION.
3. ALL PAVEMENT CUT AREAS SHALL BE COLD PATCHED OR PLATED AT THE END OF EACH WORK SHIFT, & THE PLATES OR PATCH MAINTAINED UNTIL FULL PAVEMENT RESTORATION IS MADE WITH ACP. COLD PATCH (IF USED) SHALL BE REPLACED WITH HOT MIX ACP WITHIN TIMEFRAME DIRECTED IN WRITING BY THE ODOT DISTRICT MANAGER OR MANAGER'S REPRESENTATIVE.
4. ACP SHALL BE A COMMERCIALY PRODUCED PLANT MIXTURE CONFORMING TO ODOT STANDARDS, OSSC 00744 (OLD "B" OR "C" DESIGNATION ON CITY DETAILS REFERS TO AGGREGATE SIZE ONLY).
5. 48" MINIMUM COVER IS REQUIRED FOR ALL GAS, ELECTRIC, TELEPHONE, FIBER OPTIC AND OTHER POTENTIALLY DANGEROUS/HIGH IMPACT UTILITY FACILITIES, ALL OTHER FACILITIES REQUIRE 36" MINIMUM COVER DEPTH.

LAST REVISION DATE: NOV 2022	
ODOT TRENCH CROSSING, TRENCH BACKFILL & SURFACE RESTORATION (NTS)	
AUMSVILLE, OR	DETAIL NO. 302D

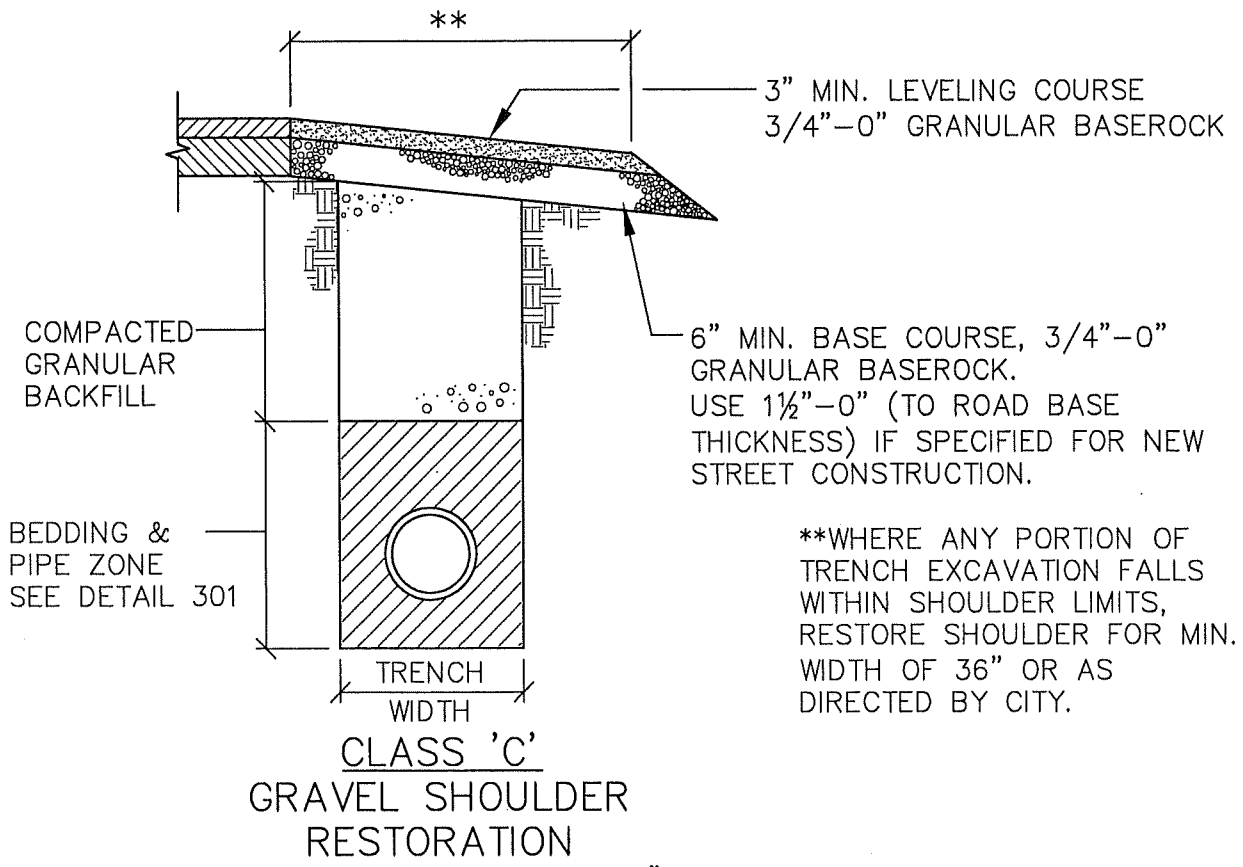

**WHERE ANY PORTION OF TRENCH EXCAVATION FALLS WITHIN SHOULDER LIMITS, RESTORE SHOULDER FOR MIN. WIDTH OF 36" OR AS DIRECTED BY CITY.

CLASS 'C'
GRAVEL SHOULDER RESTORATION

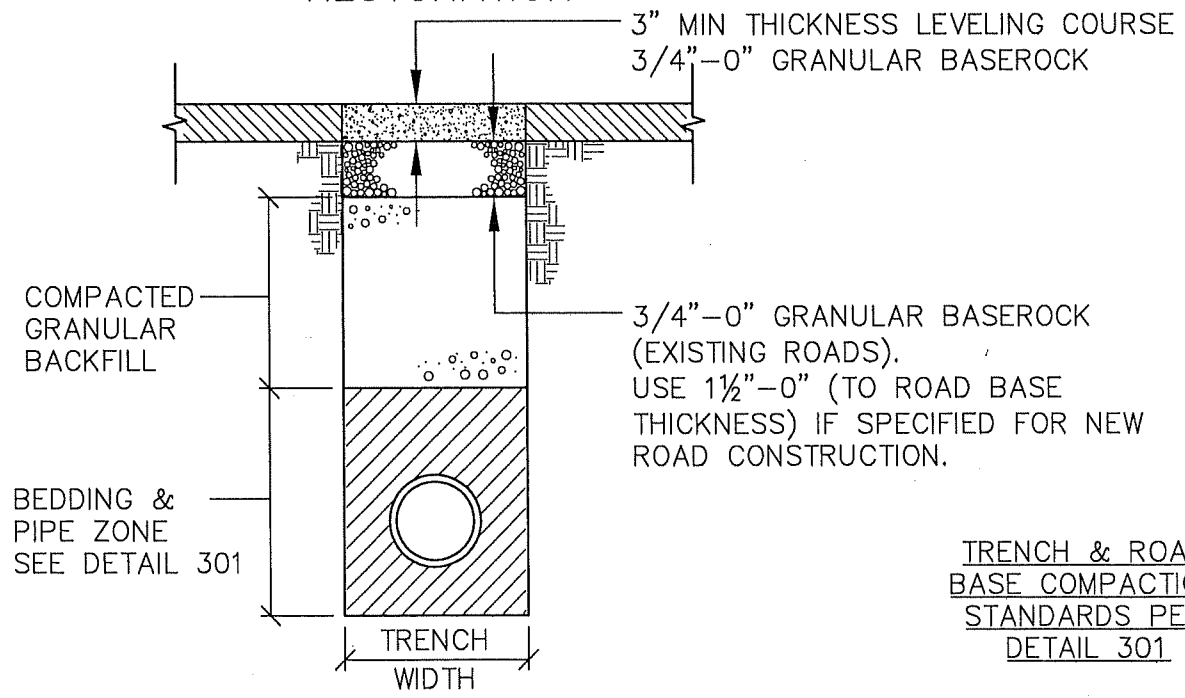

TRENCH & ROAD
BASE COMPACTION
STANDARDS PER
DETAIL 301

CLASS 'D'
GRAVEL STREET RESTORATION

NOTES:

1. SHOULDER ROCK TO BE COMPACTED TO ROAD BASEROCK STANDARDS.

LAST REVISION DATE: FEB 2021	
GRAVEL SURFACE RESTORATION	
(NTS)	
AUMSVILLE, OR	DETAIL NO. 303

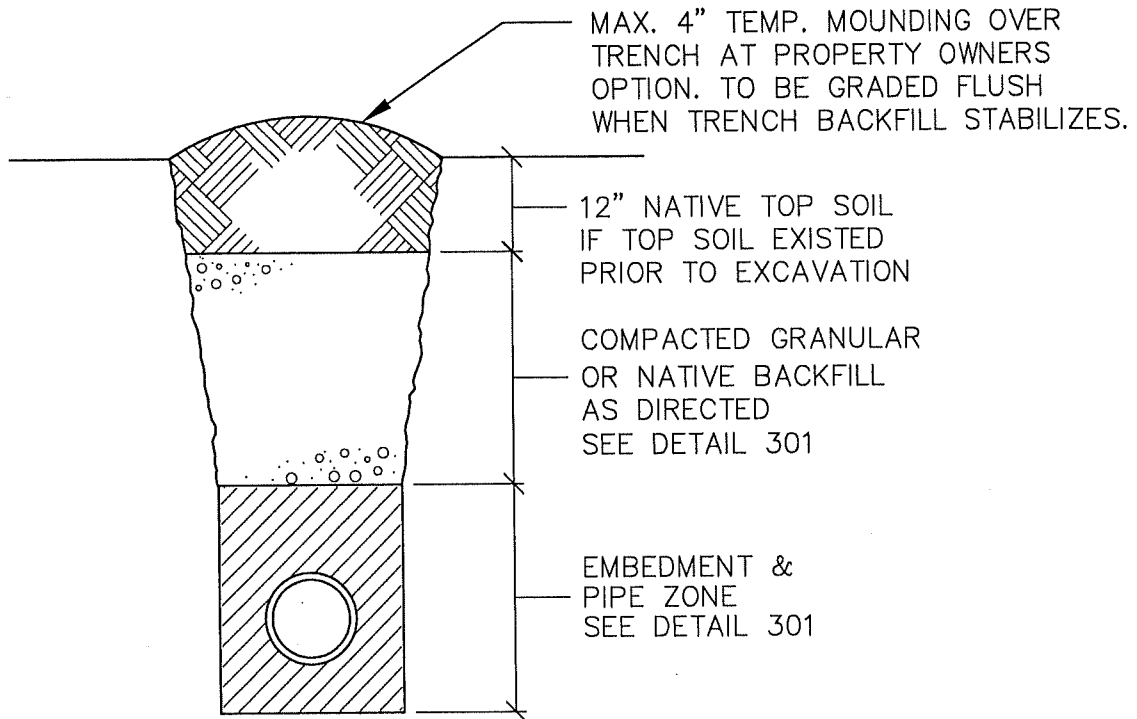

CLASS 'E'
UNIMPROVED & OPEN AREAS

TRENCH & ROAD
BASE COMPACTION
STANDARDS PER
DETAIL 301

NOTES:

1. ANY TRENCH SETTLEMENT DURING WARRANTY PERIOD SHALL BE CORRECTED AT CONTRACTOR'S EXPENSE, INCLUDING SURFACE RESTORATION.

LAST REVISION DATE: FEB 2021	
NATIVE SURFACE RESTORATION	
(NTS)	
AUMSVILLE, OR	DETAIL NO. 304

ALL JOINTS & PENETRATIONS SHALL BE GROUTED SMOOTH, SO AS NOT TO RETAIN DEBRIS. BASE TO BE SMOOTH TO FACILITATE CLEANING.

SEE DETAIL 312 FOR FRAME & GRATE

NORMAL SLOPE OF PAVEMENT

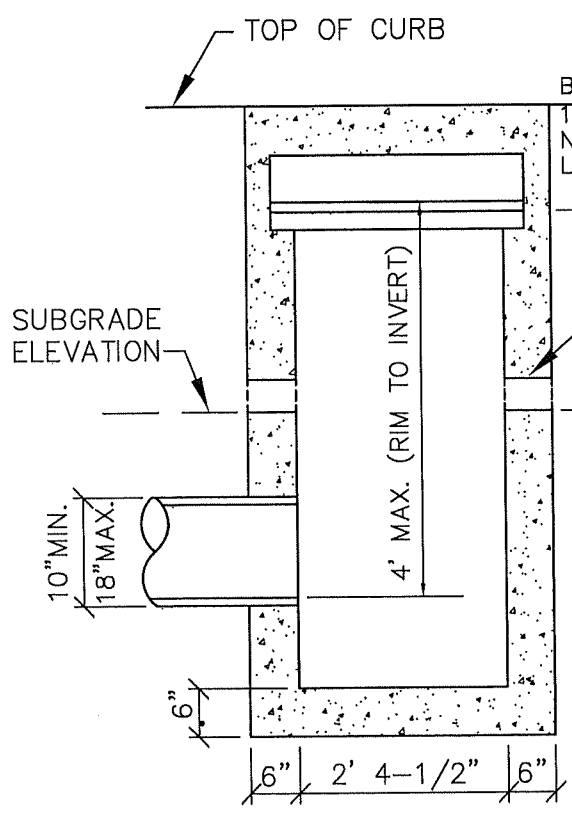

SECTION A-A

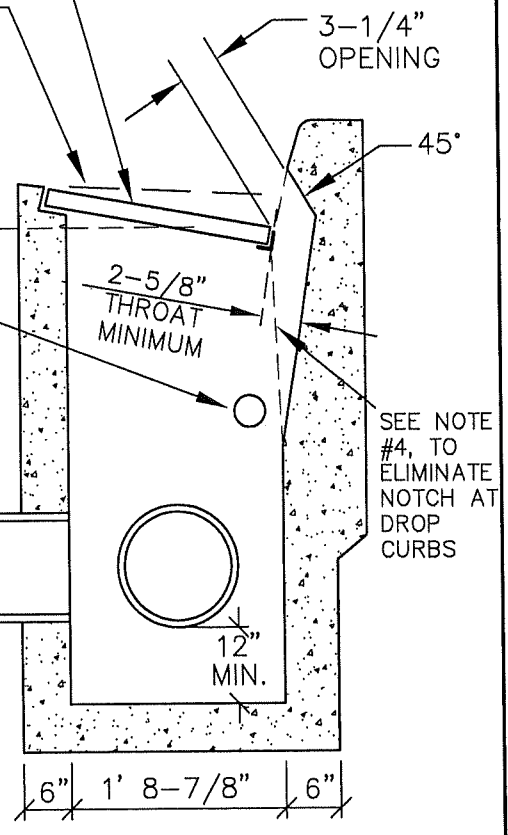

SECTION B-B

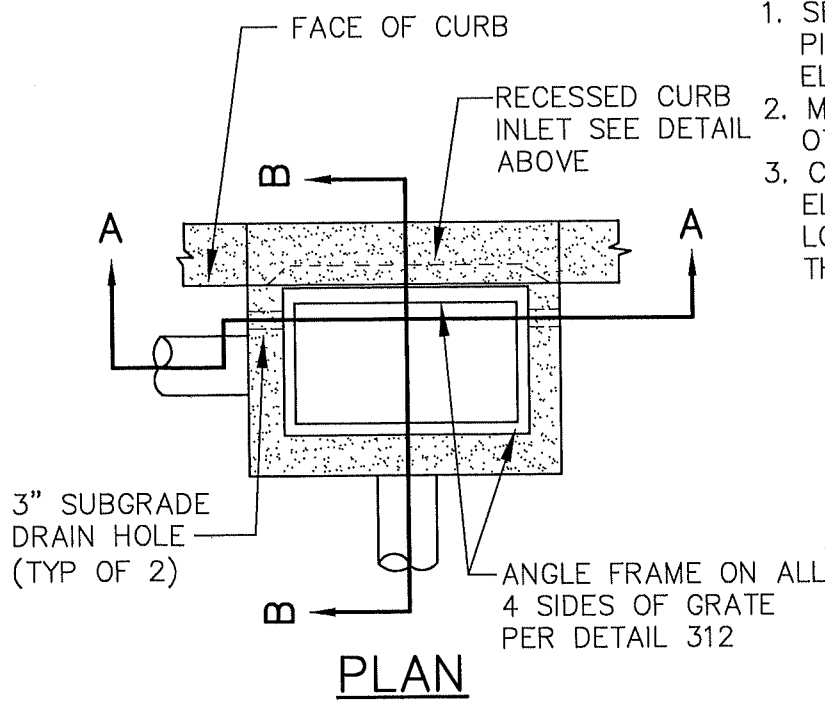

PLAN

NOTES:

1. SEE CONSTRUCTION DRAWINGS FOR PIPE SIZE, LOCATION AND INVERT ELEVATION.
2. MATCH EXISTING CURB UNLESS OTHERWISE NOTED.
3. CURB-INLET NOTCH TO BE ELIMINATED AT DROP CURB LOCATIONS WHERE APPROVED BY THE CITY ENGINEER.

PRECAST CONCRETE TO BE 4000 PSI @ 28 DAYS. CAST-IN-PLACE CONCRETE SHALL BE 3300 PSI @ 28 DAYS, MAX 5" SLUMP, 4.5% AIR (±1.5%).

LAST REVISION DATE: FEB 2021	COPYRIGHT 1996 WESTECH ENGINEERING, INC.
STANDARD SIDE-INLET GRATED CATCH BASIN	
(NTS)	
AUMSVILLE, OR	DETAIL NO. 310

ALL JOINTS & PENETRATIONS SHALL BE GROUTED SMOOTH, SO AS NOT TO RETAIN DEBRIS. BASE TO BE SMOOTH TO FACILITATE CLEANING.

SEE DETAIL 312 FOR FRAME & GRATE

NORMAL SLOPE OF PAVEMENT

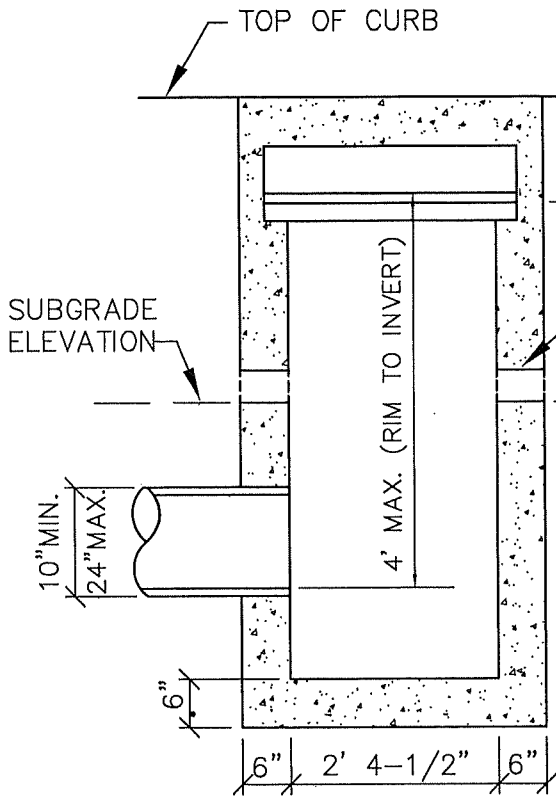

BACK OF GRATE
1-1/2" BELOW
NORMAL GUTTER
LEVEL

SUBGRADE
DRAIN

4" MAX. (RIM TO INVERT)

SUBGRADE
ELEVATION

10" MIN.
24" MAX.

6"

6" 2' 4-1/2" 6"

SECTION A-A

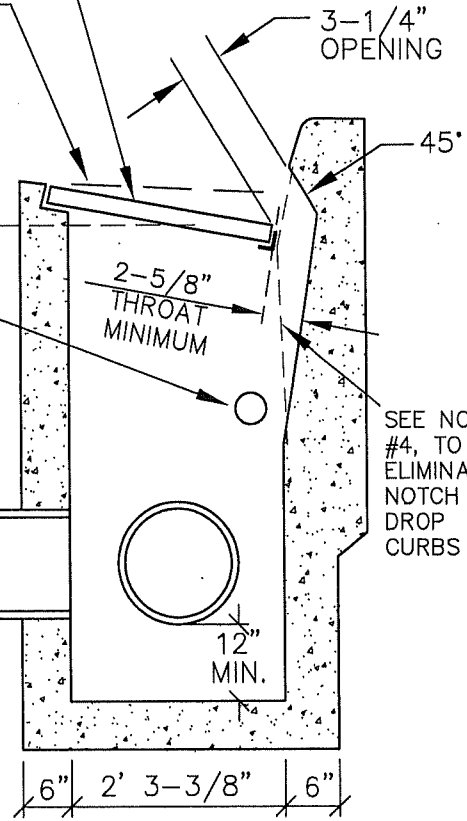

3-1/4" OPENING

45°

2-5/8" THROAT MINIMUM

SEE NOTE #4, TO ELIMINATE NOTCH AT DROP CURBS

10" MIN.
24" MAX.

12" MIN.

6" 2' 3-3/8" 6"

SECTION B-B

NOTES:

1. SEE CONSTRUCTION DRAWINGS FOR PIPE SIZE, LOCATION AND INVERT ELEVATION.
2. MATCH EXISTING CURB UNLESS OTHERWISE NOTED.
3. CURB-INLET NOTCH TO BE ELIMINATED AT DROP CURB LOCATIONS WHERE APPROVED BY THE CITY ENGINEER.

PRECAST CONCRETE TO BE 4000 PSI @ 28 DAYS. CAST-IN-PLACE CONCRETE SHALL BE 3300 PSI @ 28 DAYS, MAX 5" SLUMP, 4.5% AIR (±1.5%).

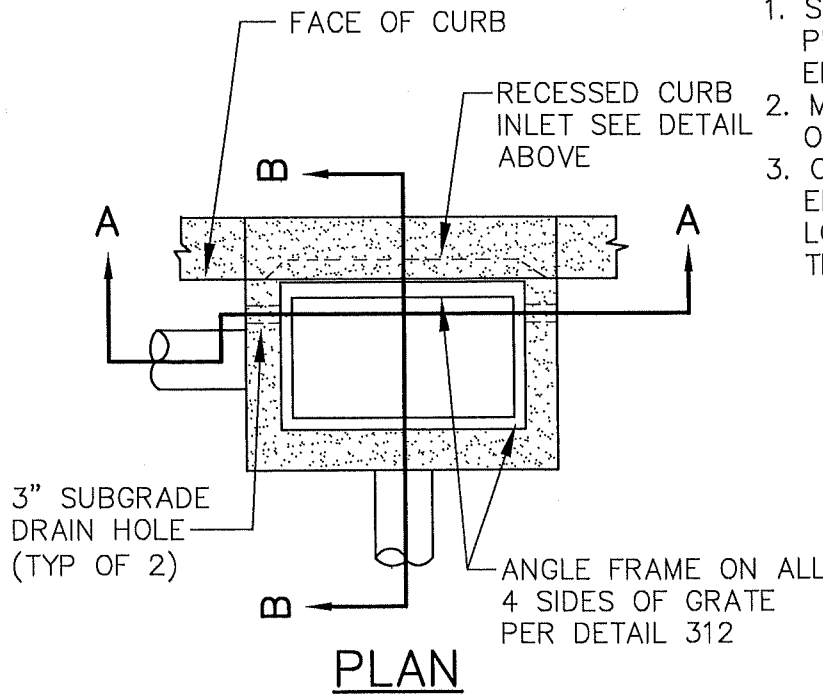

PLAN

LAST REVISION DATE: FEB 2021	COPYRIGHT 1996 WESTECH ENGINEERING, INC.
OVERSIZE SIDE-INLET GRATED CATCH BASIN	
(NTS)	
AUMSVILLE, OR	DETAIL NO. 311

FOR USE ONLY WHERE SPECIFICALLY APPROVED OR REQUIRED BY PUBLIC WORKS DIRECTOR AND CITY ENGINEER.

ALL JOINTS & PENETRATIONS SHALL BE GROUTED SMOOTH, SO AS NOT TO RETAIN DEBRIS. BASE TO BE SMOOTH TO FACILITATE CLEANING.

1/2" DIA GALVANIZED DEBRIS RODS, GROUT INTO CURB @ BASE

TOP OF CURB

BOTTOM OF INLET
1-1/2" BELOW
NORMAL GUTTER
LEVEL

SUBGRADE
ELEVATION

10" MIN.
18" MAX.

6"

6" 30" 6"

SECTION A-A

NORMAL SLOPE
OF PAVEMENT

SUBGRADE
DRAIN

10" MIN.
24" MAX.

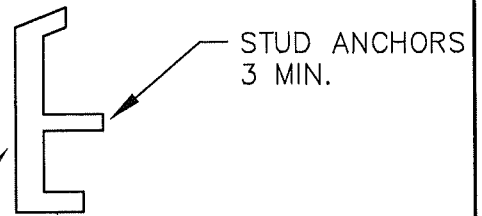

STUD ANCHORS
3 MIN.

1/4" x 3-1/2" x 1" GALVANIZED
STEEL CHANNEL W/ANCHORS

1.5%

4' 6" MAX. (RIM TO INVERT)

12" MIN.

6" 23" 6"

SECTION B-B

INSTALL ONE FULL
SIDEWALK PANEL
WITH CATCH BASIN
CONSTRUCTION

CAST IRON MANHOLE
FRAME & LID WITH
ANTI-SLIP DIAMOND
GROOVE PATTERN &
PICK HOLE

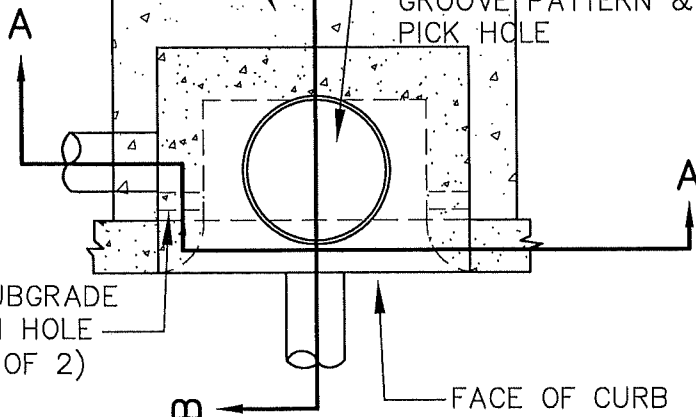

3" SUBGRADE
DRAIN HOLE
(TYP. OF 2)

FACE OF CURB

PLAN

NOTES:

1. SEE CONSTRUCTION DRAWINGS FOR PIPE SIZE, LOCATION AND INVERT ELEVATION.
2. MATCH EXISTING CURB UNLESS OTHERWISE NOTED.

PRECAST CONCRETE TO BE 4000 PSI @ 28 DAYS. CAST-IN-PLACE CONCRETE SHALL BE 3300 PSI @ 28 DAYS, MAX 5" SLUMP, 4.5% AIR (±1.5%).

LAST REVISION DATE:
FEB 2021

COPYRIGHT 1996
WESTECH ENGINEERING, INC.

**CURB-INLET
CATCH BASIN
(SPECIAL USE ONLY)**

(NTS)

AUMSVILLE, OR

DETAIL NO.

311A

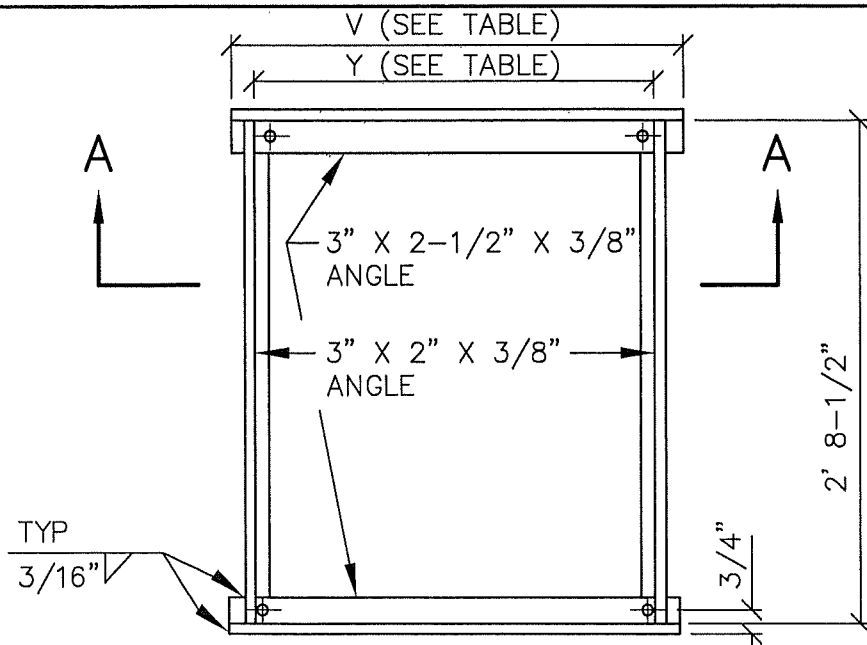

PLAN

NOTE:

3/8" ROUND OR RECTANGULAR CROSS BARS SHALL BE FILLET WELDED, RESISTANCE WELDED OR ELECTROFORGED TO BEARING BARS.

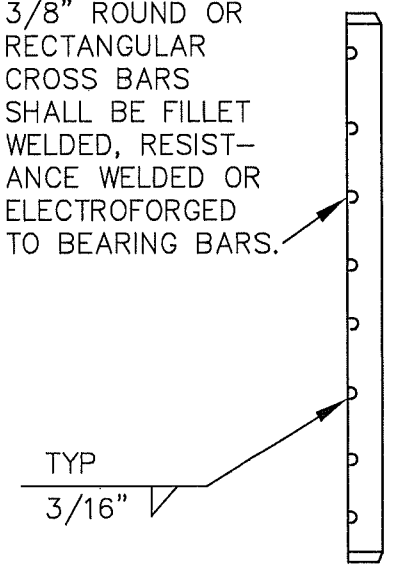

SECTION B-B

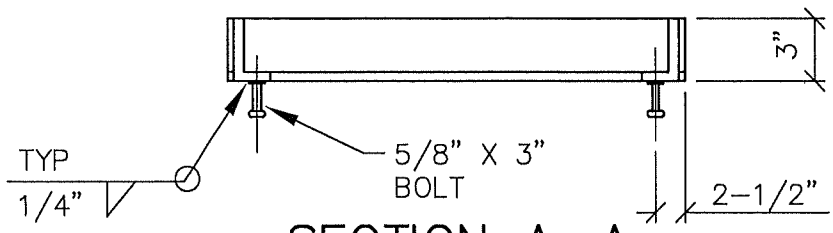

SECTION A-A

3/8" X 2" FLAT BAR EA. END

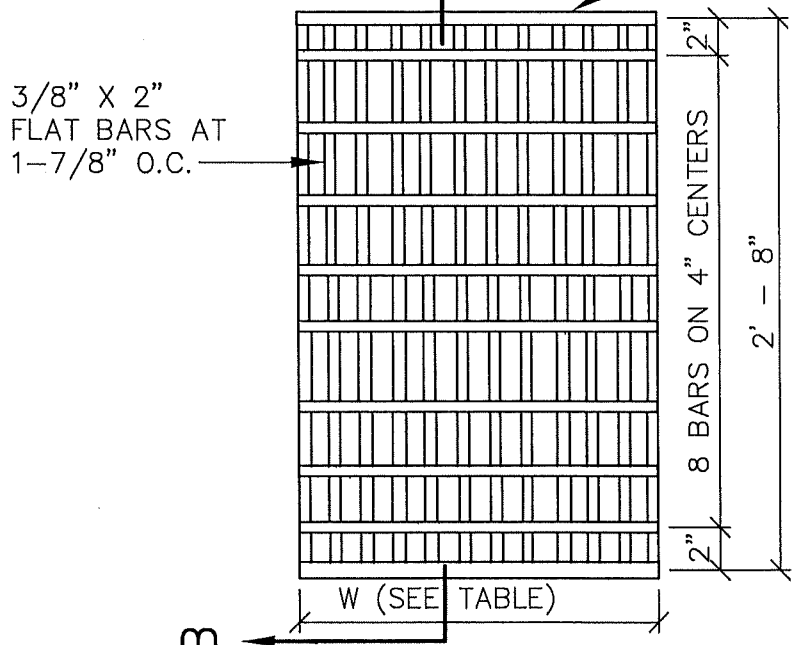

PLAN

NOTE:

1. USE VERTICAL BEADS IN CORNERS, FILLET WELD JOINT ON BOTTOM OF FRAME. GRATE MUST REST FLAT ON FRAME SURFACE.
2. ALL STEEL SHALL BE ASTM A-36.
3. ANGLE FRAME REQUIRED ON ALL FOUR SIDES OF GRATE OPENING AS SHOWN.

INLET TYPE	FRAME		GRATE		REMARKS
	V	Y	W	NO. OF BARS	
STANDARD	1' 10-3/4"	1' 9-3/8"	1'- 9"	12	1-GRATE
OVERSIZE	2' 4-3/4"	2' 3-3/8"	1' 1-1/2"	8	2-GRATES

LAST REVISION DATE: FEB 2021	COPYRIGHT 1996 WESTECH ENGINEERING, INC.
CATCH BASIN GRATE DETAILS	
(NTS)	
AUMSVILLE, OR	DETAIL NO. 312

NOTE: CONTRACTOR TO VERIFY CB DATA & FINISH GRADE ELEV'S PRIOR TO INSTALLATION TO ENSURE THAT TOP OF CB DOES NOT EXTEND ABOVE SURROUNDING GRADE UNLESS OTHERWISE SPECIFICALLY NOTED ON THE DRAWINGS OR APPROVED BY THE CITY.

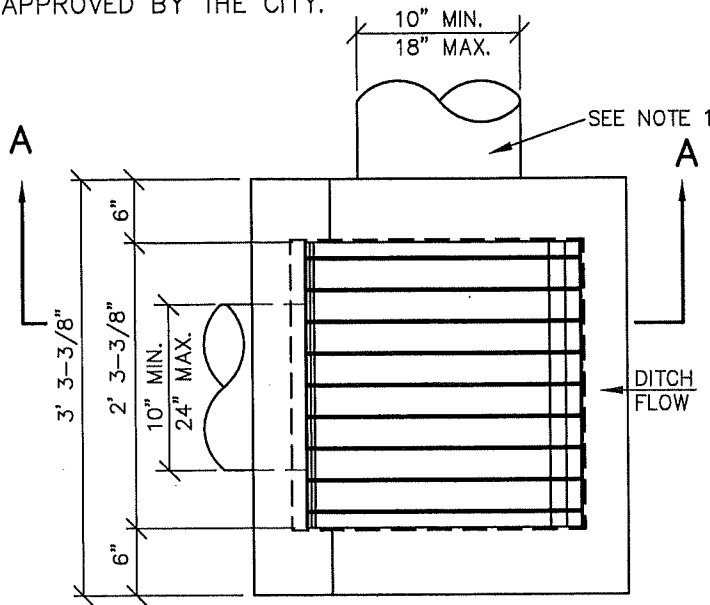

PLAN

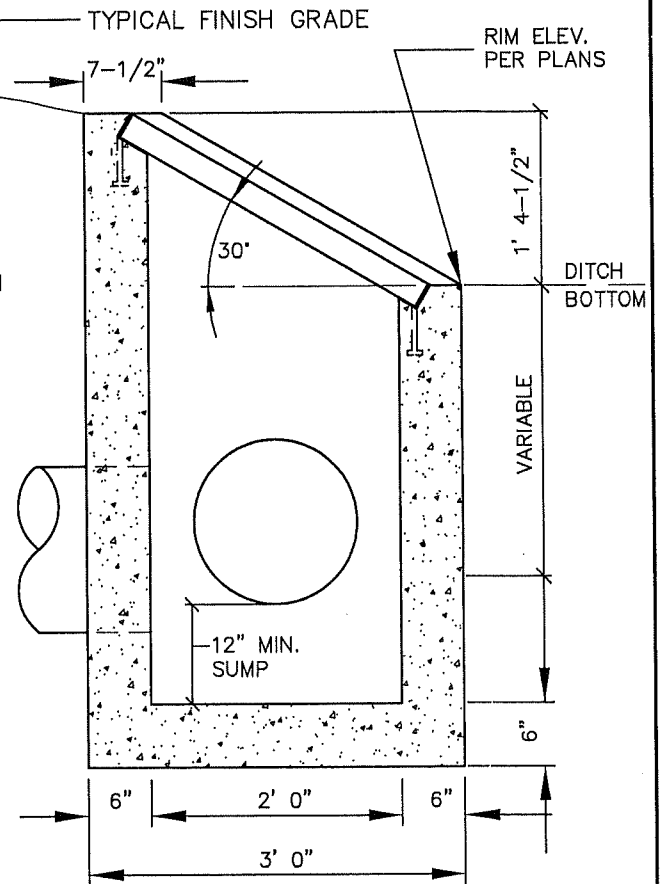

SECTION A - A

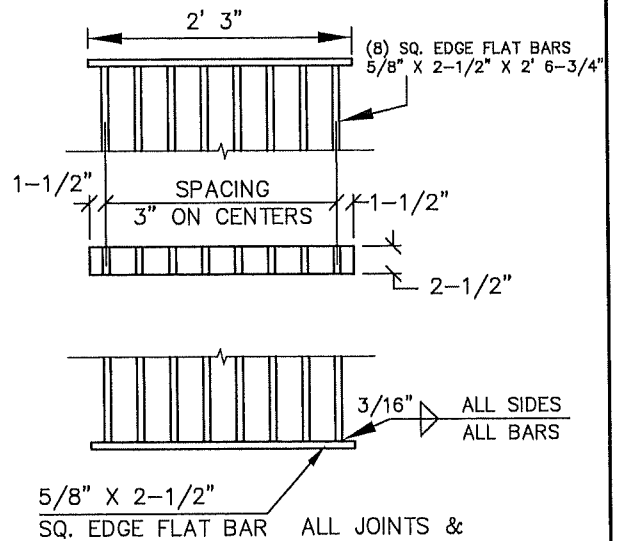
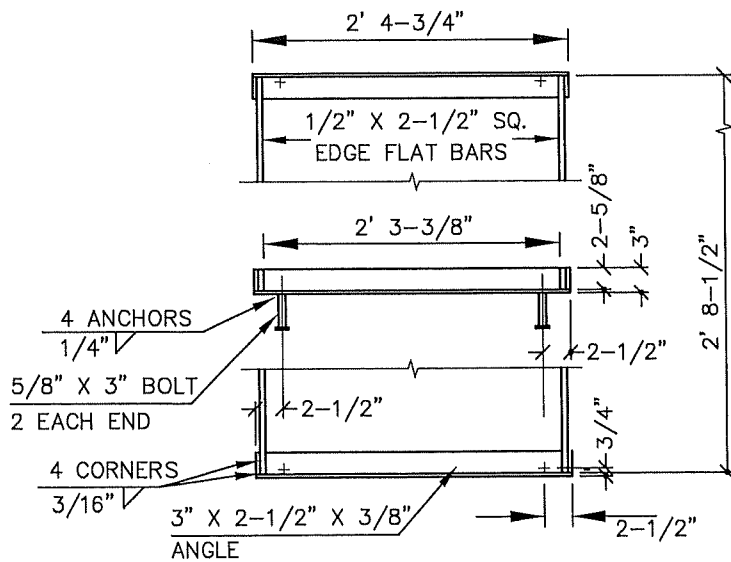

NOTES:

FRAME & GRATE

1. SEE CONSTRUCTION DRAWINGS FOR PIPE SIZE, LOCATION AND INVERT ELEVATION.
2. FRAME & GRATE SHALL BE ASTM A-36 STEEL, HOT-DIPPED GALV. AFTER CONSTRUCTION.
3. ALL CONCRETE TO BE 4000 PSI MIN AT 28 DAYS.
4. PRIOR TO CB INSTALLATION, CONTRACTOR SHALL VERIFY RIM ELEVATIONS LISTED AGAINST DITCH & FINISH GRADE ELEVATIONS, & NOTIFY CITY OF ANY DISCREPANCIES.

LAST REVISION DATE: FEB 2021	COPYRIGHT 1998 WESTECH ENGINEERING, INC.
TYPE 3 DITCH INLET CATCH BASIN	
(NTS)	
AUMSVILLE, OR	DETAIL NO. 313

NOTE: CONTRACTOR TO VERIFY FINISH GRADE ELEV'S PRIOR TO INSTALLATION TO ENSURE THAT TOP OF OUTLET STRUCTURE DOES NOT EXTEND ABOVE SURROUNDING GRADE UNLESS OTHERWISE NOTED ON DWGS OR APPROVED BY CITY. PROVIDE OUTLET PIPE & OUTLET CHANNEL (LENGTH & CONFIGURATION PER NOTE 4) AS NOTED UNLESS OTHERWISE SHOWN ON APPROVED DWGS OR REQUIRED BY CITY.

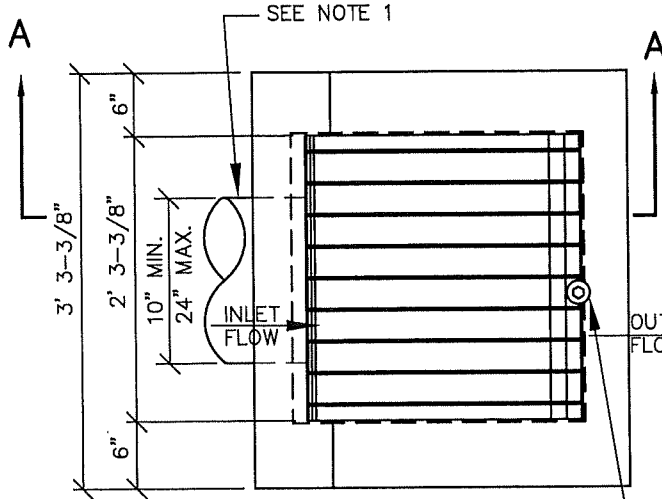

PLAN

INSTALL SINGLE 1/2" ST. STEEL EXPANSION ANCHOR BOLT & 2" SS PLATE WASHER UNLESS OTHERWISE APPROVED OR REQUIRED BY CITY

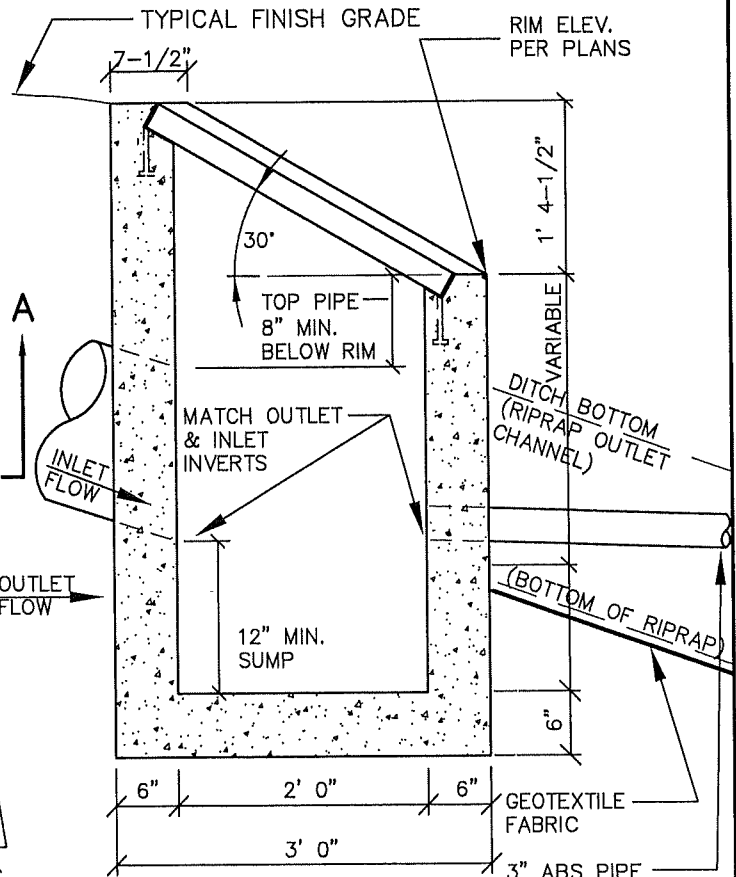

SECTION A - A

3" ABS PIPE TYP, EXTEND TO DAYLIGHT, 0.5% MIN SLOPE

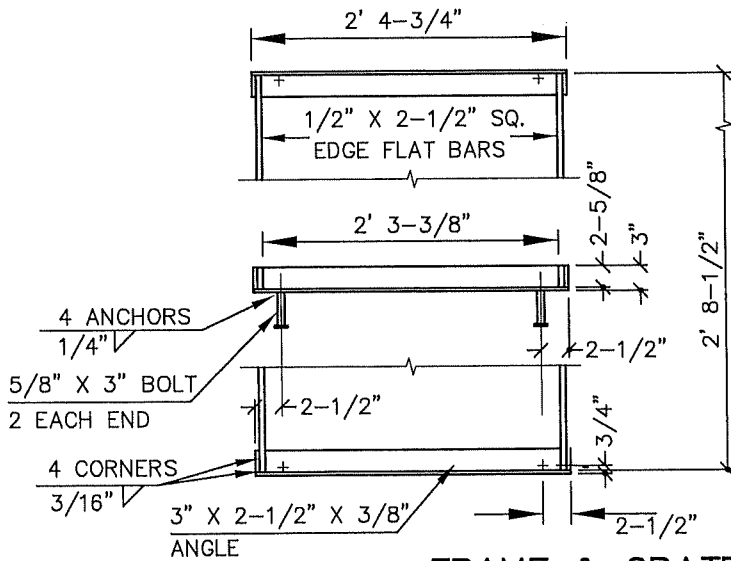

FRAME & GRATE

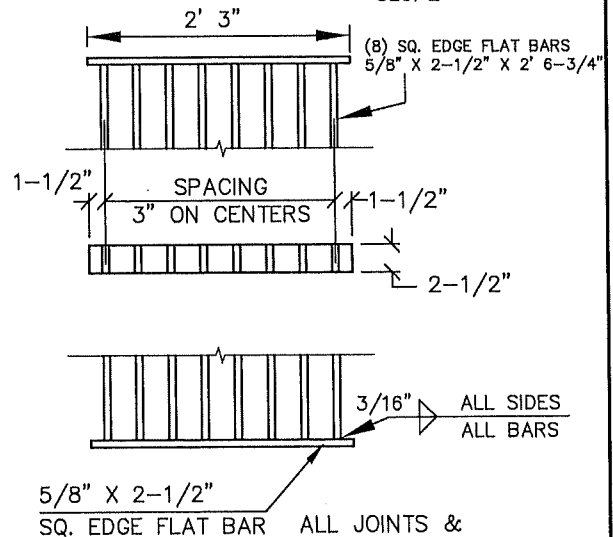

ALL JOINTS & PENETRATIONS SHALL BE GROUTED SMOOTH, SO AS NOT TO RETAIN DEBRIS.

NOTES:

1. SEE CONSTRUCTION DRAWINGS FOR PIPE SIZE, LOCATION AND INVERT ELEVATION.
2. FRAME & GRATE SHALL BE ASTM A-36 STEEL, HOT-DIP GALV AFTER CONSTRUCTION.
3. ALL CONCRETE TO BE 4000 PSI MIN AT 28 DAYS.
4. PROVIDE RIPRAP OUTLET CHANNEL (TYP 18" MIN THICK) W/2H:1V SIDE SLOPES, 12" MIN CHANNEL DEPTH & LENGTH AS NOTED ON DRAWINGS (10' MIN). PROVIDE GEOTEXTILE UNDER RIPRAP TO TOP OF BANK (NO LAPS). USE 5"-12" GRADED ANGULAR RIPRAP (TYP), FILL VOIDS BETWEEN STONE WITH 3/4"-0 BASEROCK.

LAST REVISION DATE: FEB 2021

COPYRIGHT 1996 WESTECH ENGINEERING, INC.

STORM OUTLET ENERGY DISSIPATOR BASIN

(NTS)

AUMSVILLE, OR

DETAIL NO.

313A

FOR USE ONLY WHERE SPECIFICALLY APPROVED BY PUBLIC WORKS DIRECTOR AND CITY ENGINEER.

ALL JOINTS & PENETRATIONS SHALL BE GROUTED SMOOTH, SO AS NOT TO RETAIN DEBRIS. BASE TO BE SMOOTH TO FACILITATE CLEANING.

1/2" DIA GALVANIZED DEBRIS RODS, GROUT INTO CURB @ BASE

TOP OF CURB

NORMAL SLOPE OF GUTTER PAN

STUD ANCHORS 3 MIN.

1/4" x 3-1/2" x 1" GALVANIZED STEEL CHANNEL W/ANCHORS

1.5%

BOTTOM OF INLET 1-1/2" BELOW NORMAL GUTTER LEVEL

SUBGRADE ELEVATION

SUBGRADE DRAIN

4' 6" MAX. (RIM TO INVERT)

10" MIN.
18" MAX.

10" MIN.
24" MAX.

12" MIN.

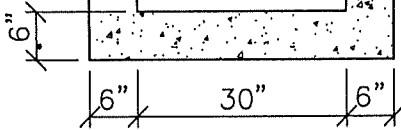

SECTION A-A

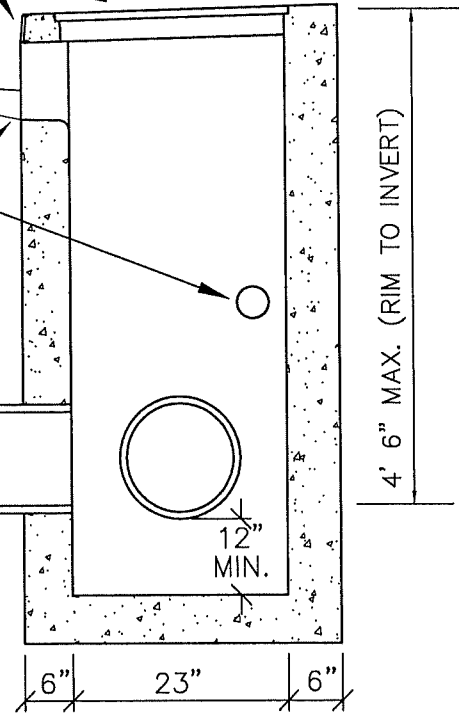

SECTION B-B

INSTALL ONE FULL SIDEWALK PANEL WITH CATCH BASIN CONSTRUCTION

CAST IRON MANHOLE FRAME & LID (PROVIDE ANTI-SLIP DIAMOND GROOVE PATTERN IN SIDEWALK AREAS)

NOTES:

1. SEE CONSTRUCTION DRAWINGS FOR PIPE SIZE, LOCATION AND INVERT ELEVATION.
2. MATCH EXISTING CURB UNLESS OTHERWISE NOTED.

PRECAST CONCRETE TO BE 4000 PSI @ 28 DAYS. CAST-IN-PLACE CONCRETE SHALL BE 3300 PSI @ 28 DAYS, MAX 5" SLUMP, 4.5% AIR (±1.5%).

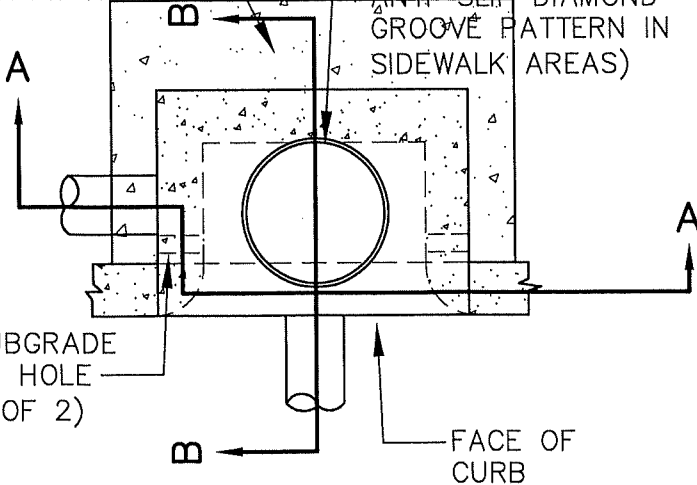

PLAN

LAST REVISION DATE: FEB 2021	COPYRIGHT 1996 WESTECH ENGINEERING, INC.
CURB-INLET CATCH BASIN	
(NTS)	
AUMSVILLE, OR	DETAIL NO. 314

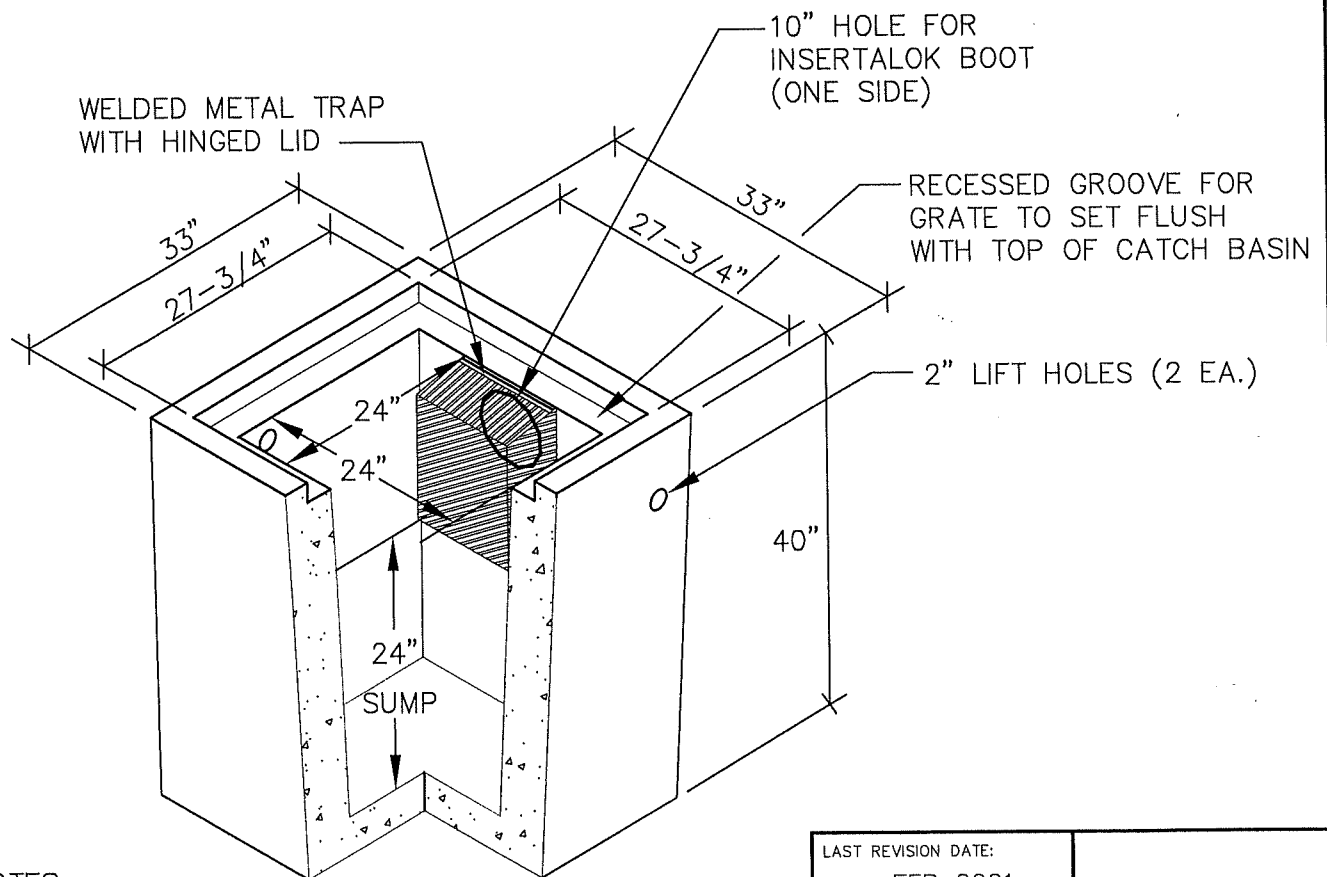
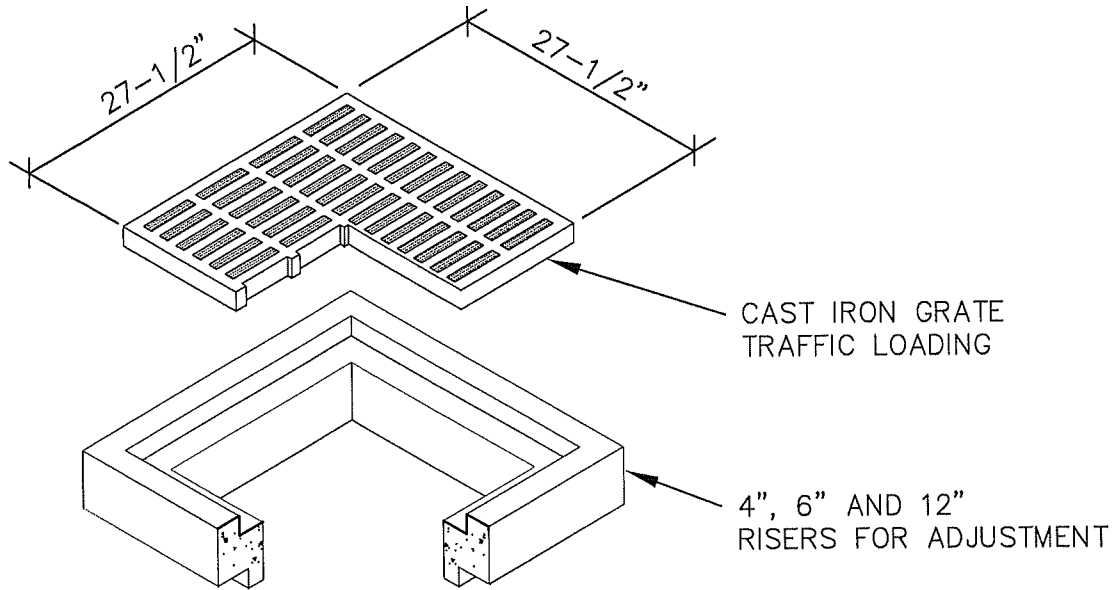

NOTES:

1. SEE CONSTRUCTION DRAWINGS FOR PIPE SIZE, LOCATION AND INVERT ELEVATION.
2. CONCRETE SHALL BE 4000 PSI @ 28 DAYS.
3. REBAR SHALL CONFORM TO ASTM A615 GRADE 60.
4. REBAR SHALL BE MIN. #4 BARS @ 6" C.C.
5. SET CB SQUARE WITH BUILDINGS OR WITH EDGE OF PARKING LOT OR DRIVEWAY WHEREIN IT LIES.
6. ADJUST PAVING SO WATER FLOWS TO CB WITH NO PONDING.

LAST REVISION DATE: FEB 2021	
PARKING LOT CATCH BASIN (PRECAST CONCRETE)	
(NTS)	
AUMSVILLE, OR	DETAIL NO. 315

CAST-IN-PLACE
REINFORCED CONCRETE
SUPPORT COLLAR

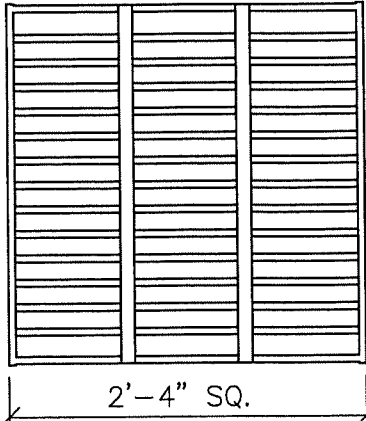

GRATE: WELDED STEEL DROP-IN
BAR GRATE (ASTM A36).
END BARS: 1/2" X 2"
CROSS BARS: 1/2" X 2" @ 2" O.C.
BIKE STRAPS: 1/8" X 1" (2 REQ'D)
16,000 LB. UNIFORM LOAD CAPACITY

GRATE DETAIL

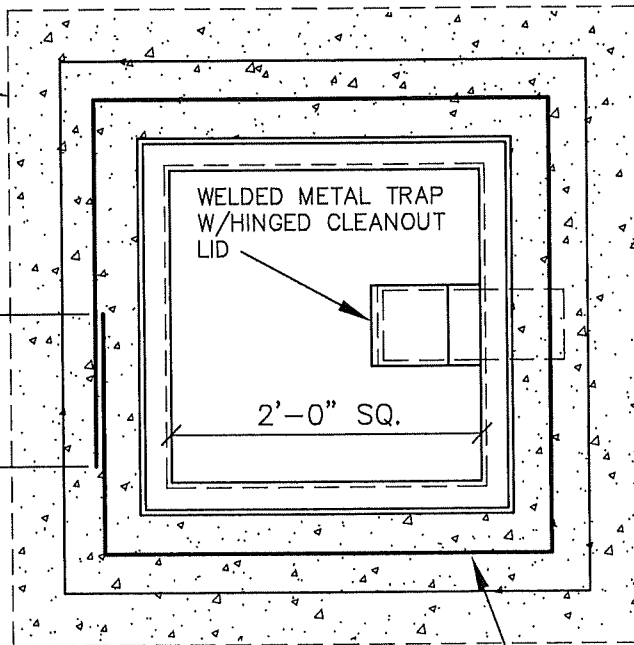

PLAN VIEW

#4 REBAR
CONTINUOUS

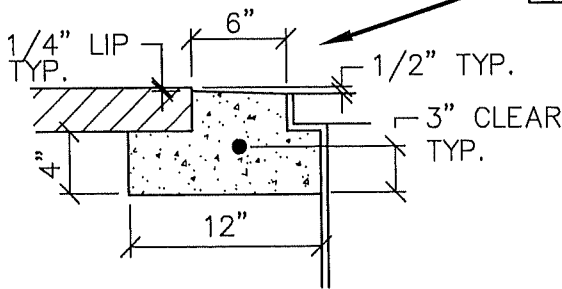

CONCRETE COLLAR

CONSTRUCT BASIN OF WELDED
1/4" STEEL. COAT ALL SURFACES
WITH ASPHALTIC PAINT.

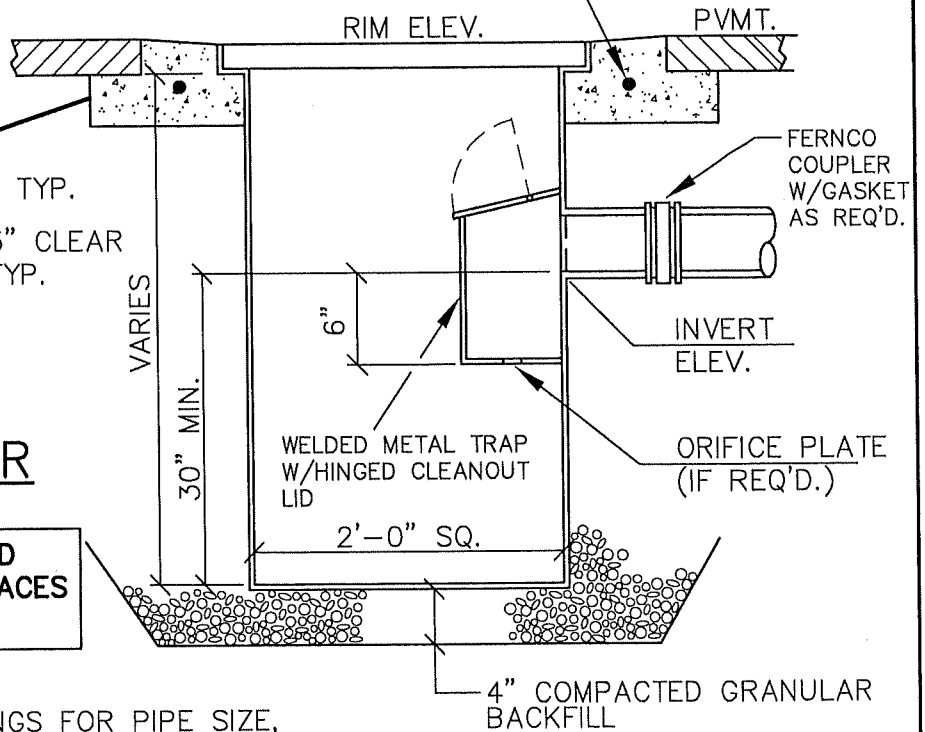

NOTES:

1. SEE CONSTRUCTION DRAWINGS FOR PIPE SIZE, LOCATION AND INVERT ELEVATION.
2. OUTLET: SIZE AS REQ'D. FOR INDICATED PIPE SIZE.
3. FOR JUNCTION BOX, REPLACE GRATE WITH 3/4" STEEL PLATE. DRILL ONE, 1" LIFTING HOLE, CENTERED IN ONE END OF THE PLATE. WELD SHIMS TO RIM AS REQUIRED TO RAISE PLATE TO RIM ELEVATION.
4. SET CB SQUARE WITH BUILDINGS OR WITH EDGE OF PARKING LOT OR DRIVEWAY WHEREIN IT LIES.
5. ADJUST PAVING SO WATER FLOWS TO CB WITH NO PONDING.

LAST REVISION DATE: FEB 2021	
PARKING LOT CATCH BASIN (LYNCH STYLE) (NTS)	
AUMSVILLE, OR	DETAIL NO. 316

SEE NOTE 5
(RE: INLET)

INSERTA-TEE CONNECTION,
SEE NOTE 3 & 4.
INSERTA-TEE SOCKET TO
MATCH PIPE MATERIAL
SPECIFIED OR NOTED ON
THE DRAWINGS.

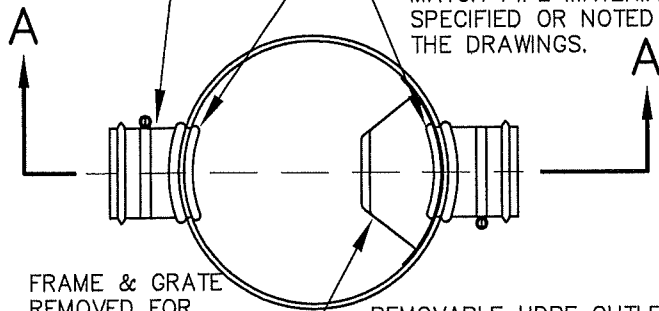

FRAME & GRATE
REMOVED FOR
CLARITY

PLAN

REMOVABLE HDPE OUTLET TRAP
REQUIRED ON ALL PRIVATE CATCH
BASINS (OMIT FOR FLOW-THRU JUNCTION
STRUCTURES). ALL CLIPS & HARDWARE
TO BE STAINLESS STEEL.

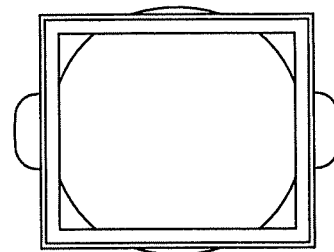

FRAME TO INCLUDE TABS THAT
MATCH BASIN OD TO PREVENT
DISPLACEMENT. FRAME BODY TO
BEAR ON COMPACTED BASEROCK
(SEE SECTION A-A)

FRAME

PAVED
SURFACE

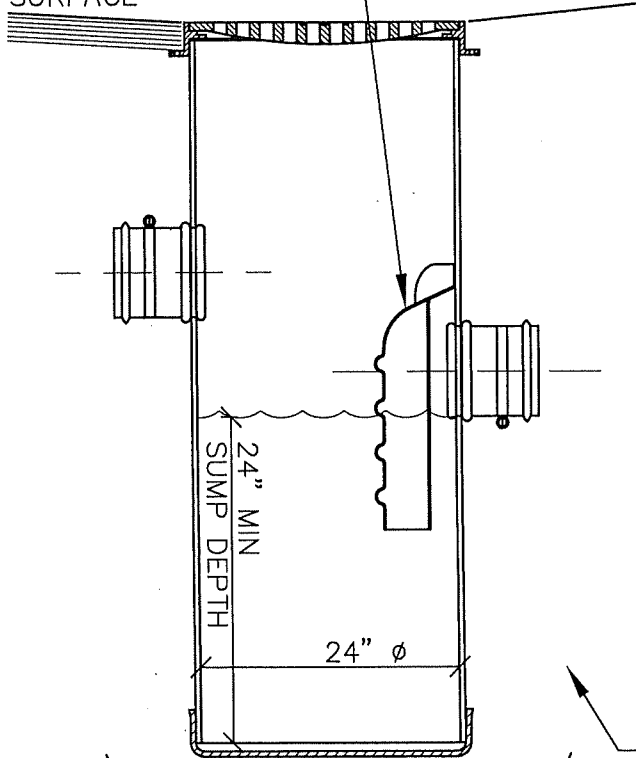

MIN 4" GRANULAR BEDDING

SECTION A-A

44 X SLOT ϕ 1.00 THRU

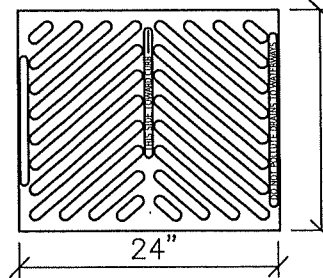

APPROX. DRAIN AREA =
202.48 SQ IN

GRATE

COMPACTED GRANULAR BACKFILL
AROUND CATCH BASINS & AREA
DRAINS (GRADE AS REQUIRED TO
SUPPORT GRATE FRAME).

NOTE: PER ORS 92.044(7),
AREA DRAIN MUST BE SET
1' MINIMUM CLEAR FROM
ANY SURVEY MONUMENT

NOTES:

1. NYLOPLAST TRAFFIC RATED DRAIN BASIN OR APPROVED EQUAL W/NYLOPLAST FRAME & GRATE.
2. HERRING-BONE STYLE GRATE TO BE DUCTILE IRON PER ASTM A536 GRADE 70-50-05.
3. SEE CONSTRUCTION DRAWINGS FOR PIPE SIZE, LOCATION, ORIENTATION AND INVERT ELEVATIONS.
4. CONNECTIONS TO PVC CATCH BASIN TO BE INSERTA-TEE STYLE FITTINGS (FACTORY OR FIELD INSTALLED).
5. FLOW-THRU CONFIGURATION SHOWN IS ALLOWED ONLY FOR AREA DRAINS OR JUNCTION BOXES.
6. SET CB GRATE SQUARE WITH BUILDINGS OR WITH EDGE OF PARKING LOT OR DRIVEWAY WHEREIN IT LIES.
7. ADJUST PAVING OR GRADING SO WATER FLOWS TO STRUCTURE INLET WITH NO PONDING.

LAST REVISION DATE: FEB 2021	JO #
PARKING LOT CATCH BASIN (TRAFFIC RATED PVC w/TRAP, DUCTILE IRON FRAME/GRATE)	
(NTS)	
AUMSVILLE, OR	DETAIL NO. 317

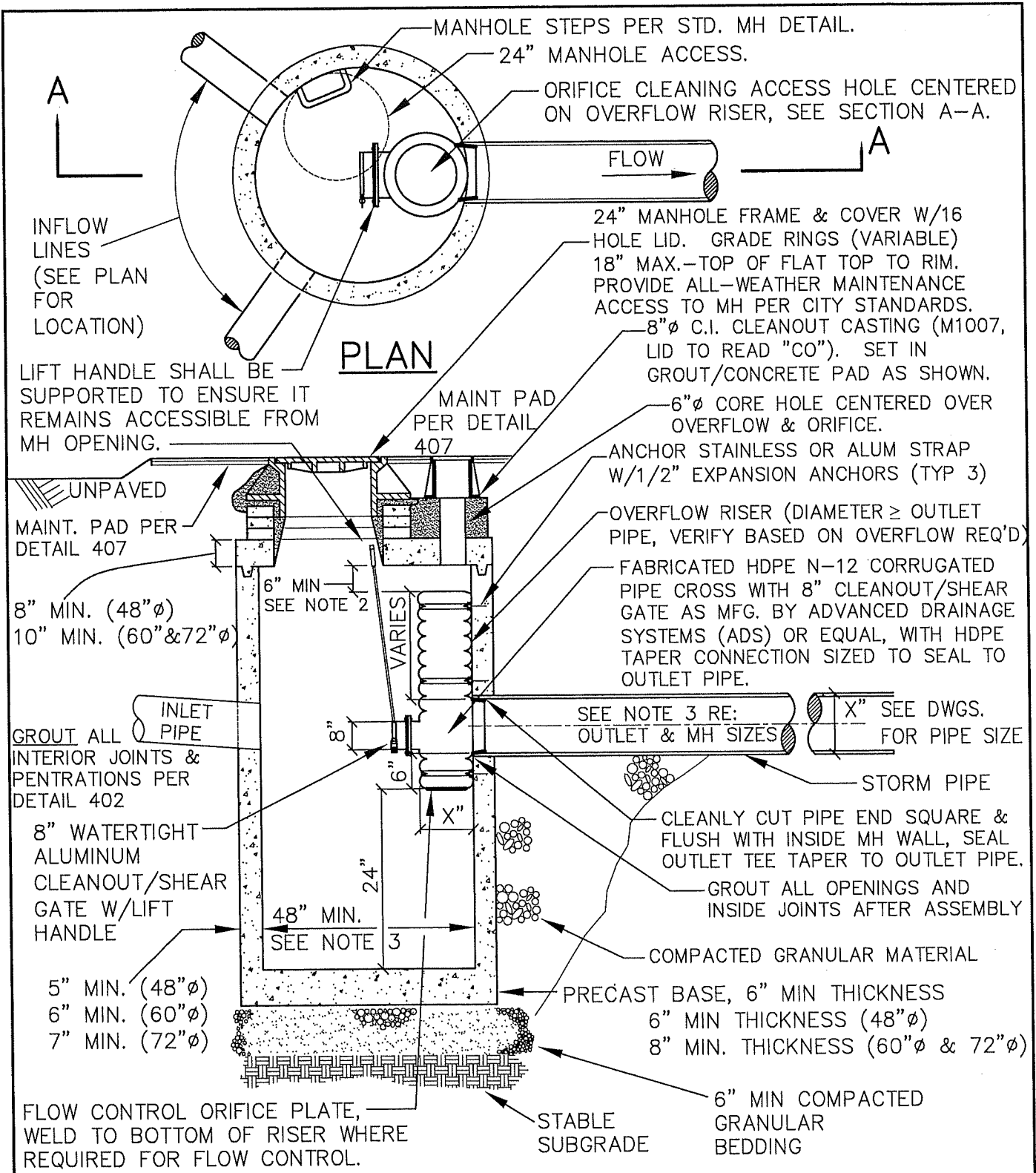

SECTION A-A

NOTES:

1. PRECAST SECTIONS SHALL CONFORM TO ASTM C-478.
2. DISTANCE FROM TOP OF OVERFLOW TO MH RIM SHALL BE BASED ON OVERFLOW CAPACITY CALC'S BY DESIGN ENGINEER (ASSUME ORIFICE CONTROL).
3. 60" MINIMUM DIA. MANHOLE REQUIRED FOR OUTLET PIPE LARGER THAN 15" OR INLET > 21".
4. ORIFICE CLEANING ACCESS TO BE 6" CORE HOLE THROUGH FLAT-TOP (CENTERED ON OVERFLOW) WITH CI CLEANOUT BOX GROUTED TO SLAB.

LAST REVISION DATE: FEB 2021	
POLLUTION/FLOW CONTROL MANHOLE W/OVERFLOW	
(NTS)	
AUMSVILLE, OR	DETAIL NO. 320

GROUT OVERSIZE
FLOW CHANNEL AS
SHOWN & TROWEL
SMOOTH.

CLEARANCE UNDER SANITARY
SEWER PIPE TO BE A MINIMUM OF
1.5 TIMES THE DIAMETER OF THE
STORM PIPE

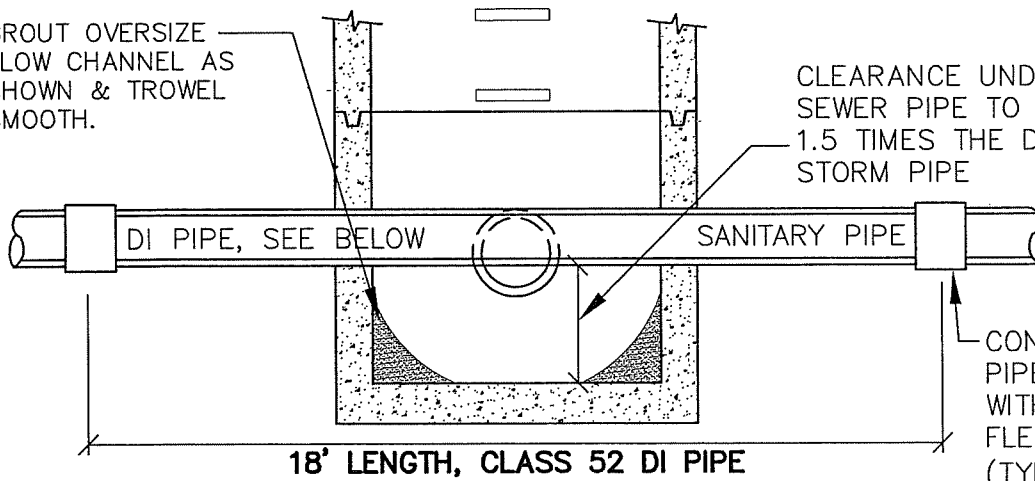

CONNECT DUCTILE IRON
PIPE TO SEWER PIPE
WITH APPROVED
FLEXIBLE COUPLING.
(TYP BOTH ENDS)
MAXADAPTOR COUPLING
(BY GRIPPER GASKET
LLC) OR EQUAL.

SECTION THRU SANITARY SEWER

MANHOLE FRAME & COVER,
SET PER DTL 407

SET FRAME IN NON-SHRINK GROUT

GROUT ALL
INTERIOR JOINTS &
PENETRATIONS PER
DETAIL 402

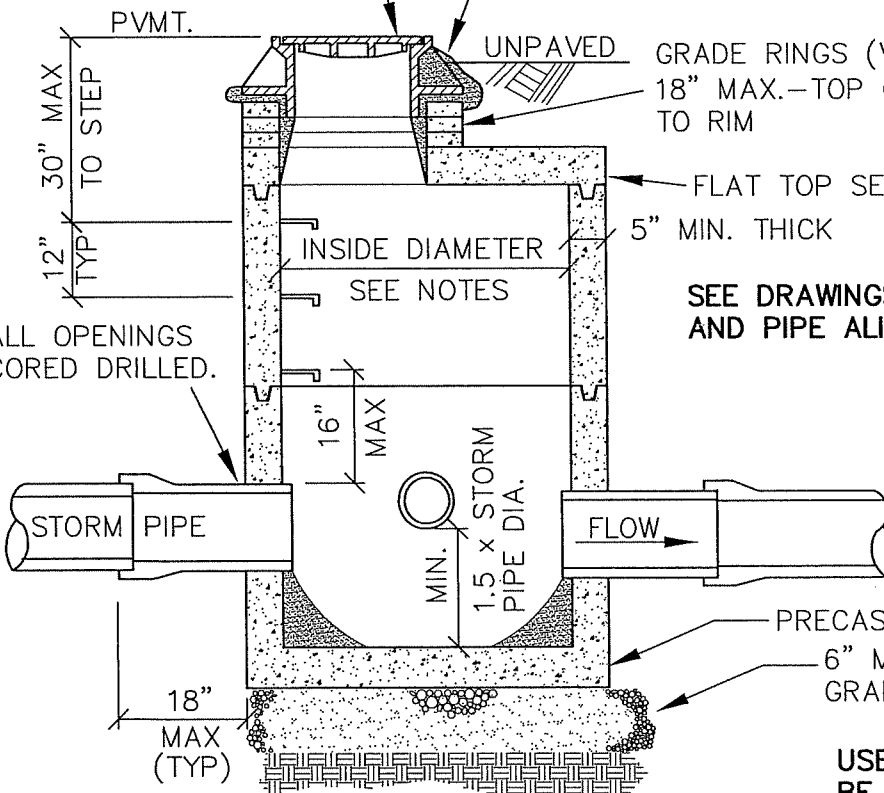

SEE DRAWINGS FOR INVERT ELEVATIONS
AND PIPE ALIGNMENTS.

SECTION THRU STORM

NOTES:

1. UNLESS OTHERWISE SHOWN ON DRAWINGS, USE 48" MANHOLE FOR SANITARY SEWER UP TO 12" DIA. & STORM DRAIN UP TO 18" DIAMETER (LARGER DIAMETER MANHOLE OTHERWISE, PER DWGS).
2. PRECAST SECTIONS SHALL MEET OR EXCEED ASTM C-478. WATERTIGHT O-RING OR MASTIC KEYLOCK JOINTS REQUIRED.
3. STEPS TO BE POLYPROPYLENE PLASTIC WITH GRADE 60 REINFORCING ROD.

**USE OF KUENZI MANHOLES MUST
BE APPROVED ON A CASE BY
CASE BASIS BY THE PUBLIC
WORKS DIRECTOR.**

LAST REVISION DATE: JULY 2022	
KUENZI MANHOLE (SEWER PIPE CROSSING)	
(NTS)	
AUMSVILLE, OR	DETAIL NO. 330

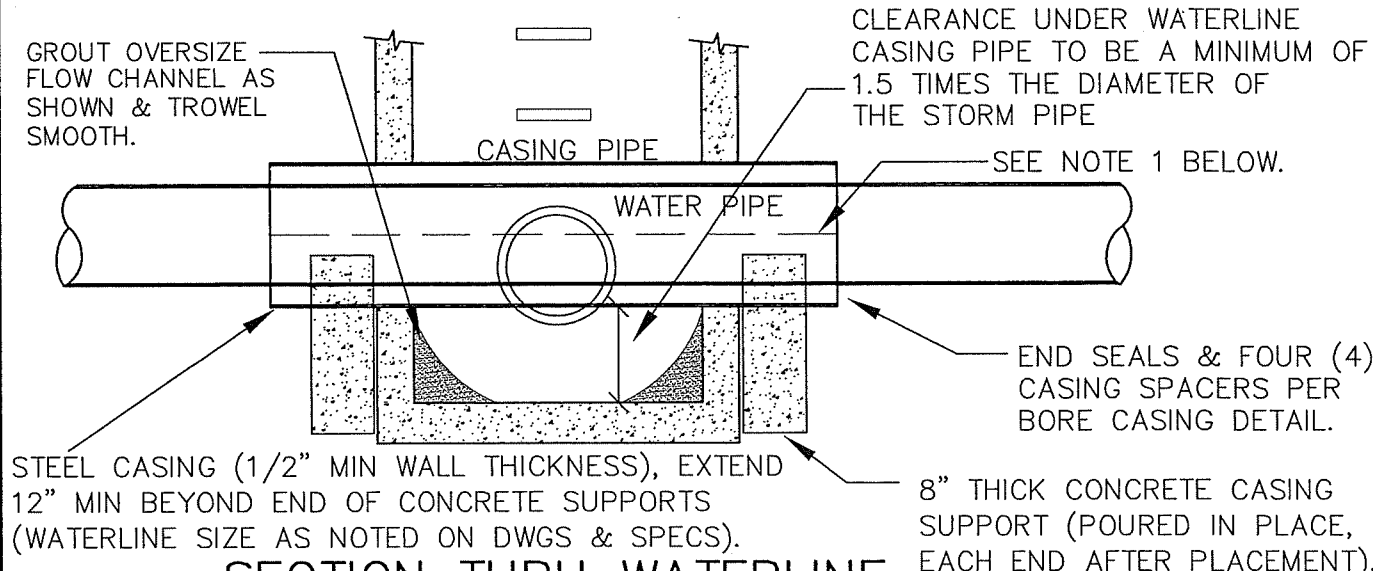

SECTION THRU WATERLINE

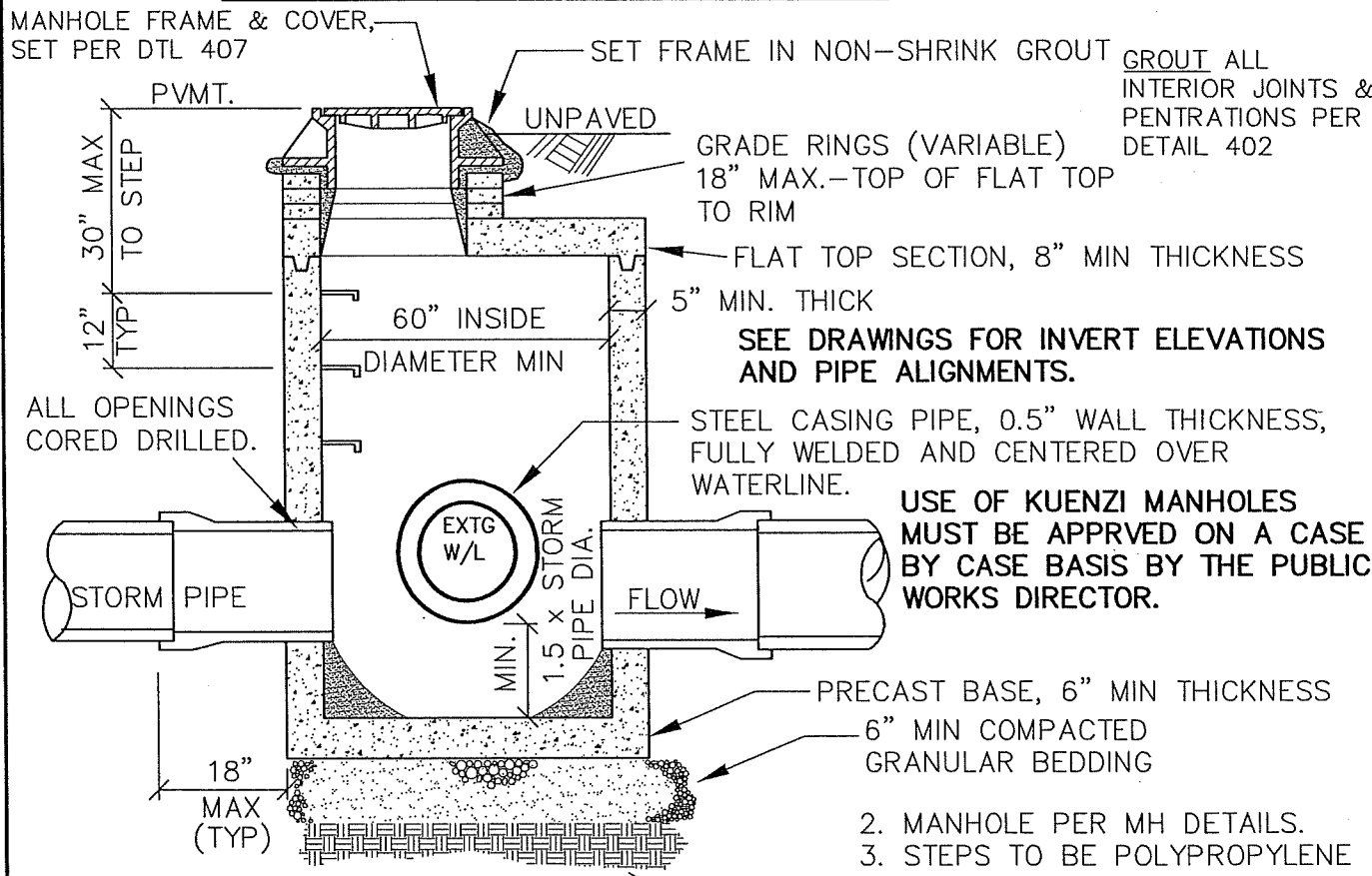

SECTION THRU STORM

1. SHOP CUT 30" CASING PIPE IN HALF (LENGTHWISE, ACROSS RADIUS) AND SHOP GRIND BEVELED EDGES FOR FULL PENETRATION WELDS. BLOCK BOTTOM HALF OF CASING PIPE IN PLACE UNDER EXISTING WATERLINE & POUR CONCRETE SUPPORTS. INSTALL CASING SPACERS (DETAIL 5080) TO SUPPORT WATERLINE & WELD HALVES OF CASING TOGETHER. USE WATER IN BOTTOM OF CASING DURING WELDING AS REQUIRED TO AVOID OVER-HEATING CASING SPACER SUPPORT LEGS.

2. MANHOLE PER MH DETAILS.
3. STEPS TO BE POLYPROPYLENE PLASTIC WITH GRADE 60 REINFORCING ROD.

LAST REVISION DATE: JULY 2022	JO # STANDARD
KUENZI MANHOLE W / WATERLINE CASING (EXISTING WATERLINE) (NTS)	
AUMSVILLE, OR	DETAIL NO. 331

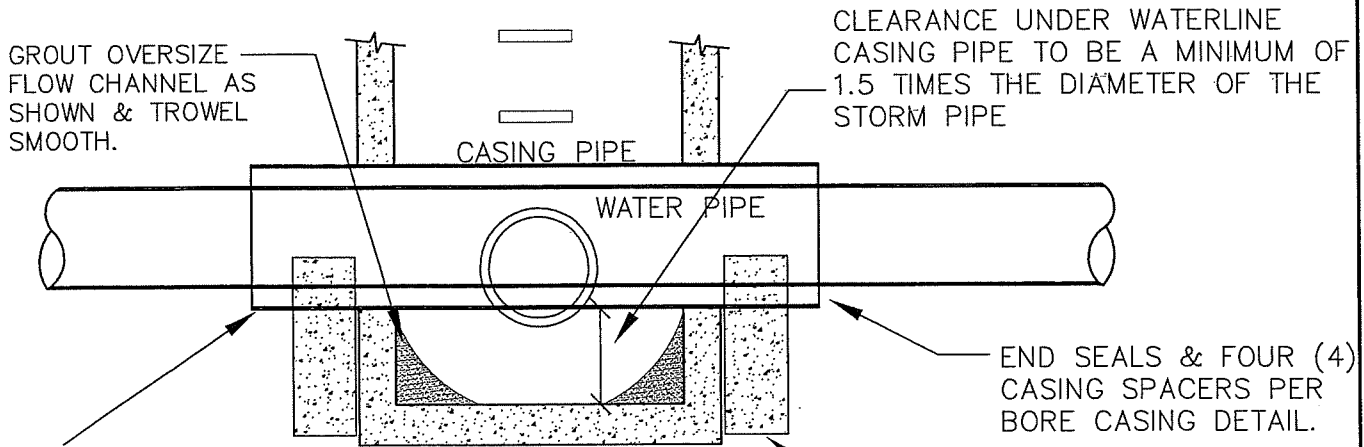

STEEL CASING (1/2" MIN WALL THICKNESS), EXTEND 12" MIN BEYOND END OF CONCRETE SUPPORTS (WATERLINE SIZE AS NOTED ON DWGS & SPECS).

8" THICK CONCRETE CASING SUPPORT (POURED IN PLACE, EACH END AFTER PLACEMENT OF CASING PIPE).

SECTION THRU WATERLINE

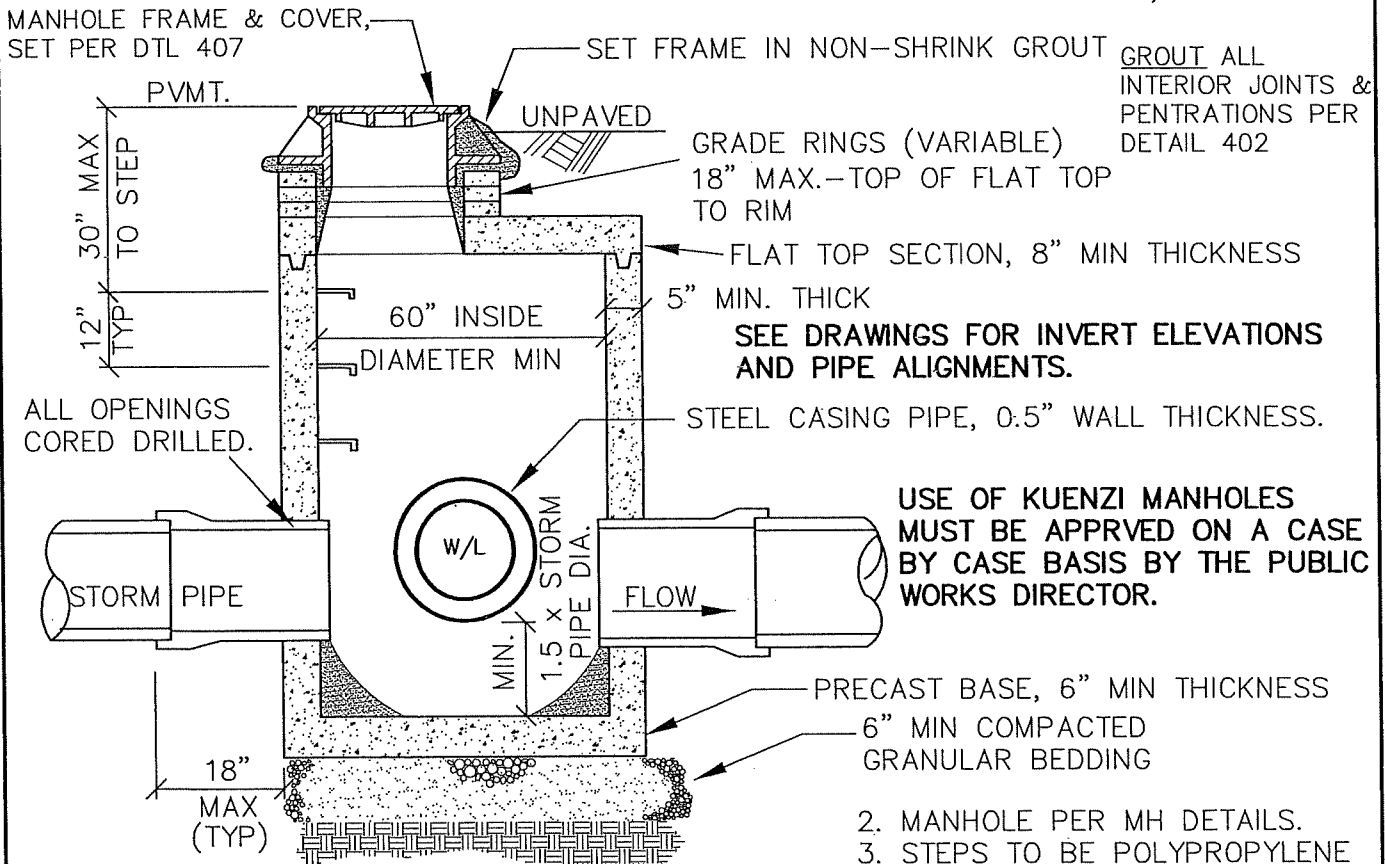

SECTION THRU STORM

1. BLOCK CASING PIPE IN PLACE & POUR CONCRETE SUPPORTS. INSTALL CASING SPACERS TO SUPPORT WATERLINE THROUGH CASING (DETAIL 5080). INSTALL END SEALS.
2. SEE PLAN VIEWS FOR WATERLINE & STORM SIZE & CONFIGURATION. USE 72" MANHOLE UNLESS OTHERWISE SHOWN ON DRAWINGS.

LAST REVISION DATE: JULY 2022	JO # STANDARD
KUENZI MANHOLE W / WATERLINE CASING (NEW WATERLINE)	
(NTS)	
AUMSVILLE, OR	DETAIL NO. 332

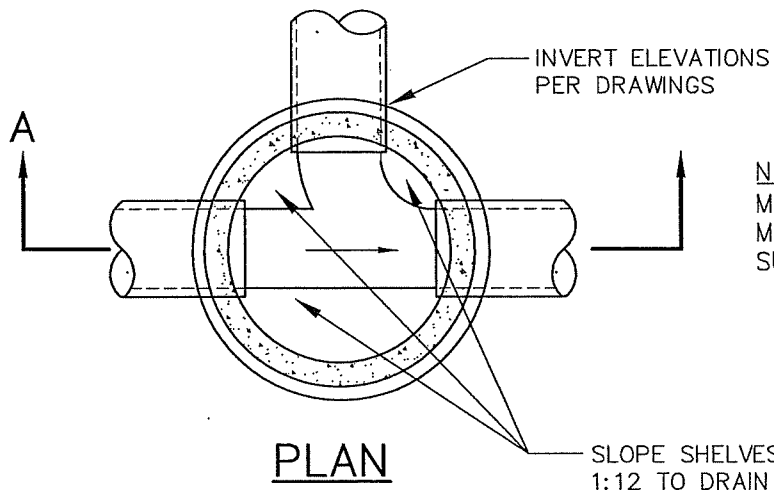

NOTE: PER ORS 92.044(7),
MANHOLE MUST BE SET 1'
MINIMUM CLEAR FROM ANY
SURVEY MONUMENT

PLAN

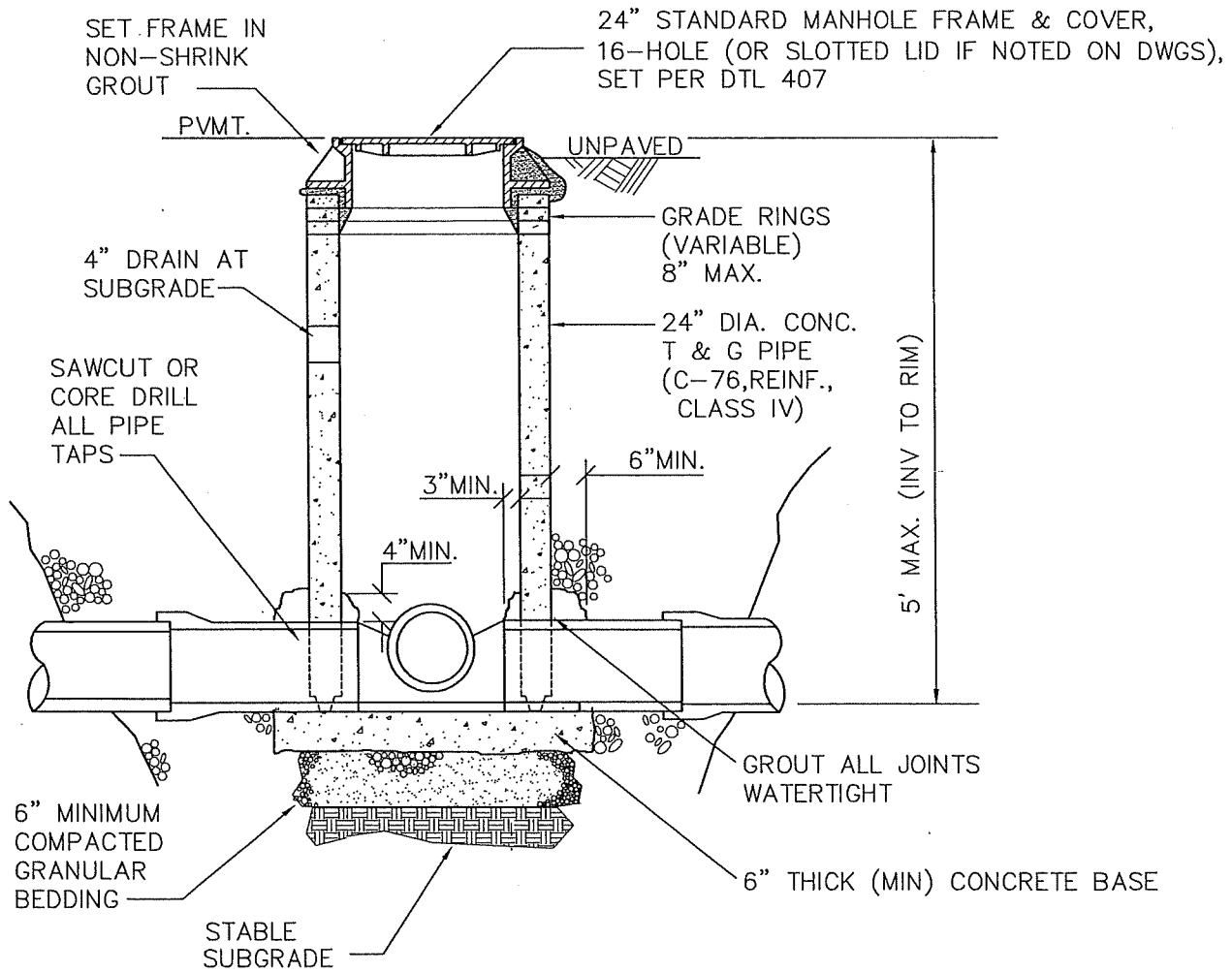

SECTION A-A

NOTE:

1. MAXIMUM PIPE NUMBER & DIAMETERS AS FOLLOWS:
 12" DIAMETER OR LESS - 4 MAXIMUM.
 15" DIAMETER - 2 MAXIMUM.
 ALL OTHER CONFIGURATIONS REQUIRE STANDARD MANHOLE.

LAST REVISION DATE: JULY 2022	
24" DIA. STORM MANHOLE	
(NTS)	
AUMSVILLE, OR	DETAIL NO. 350

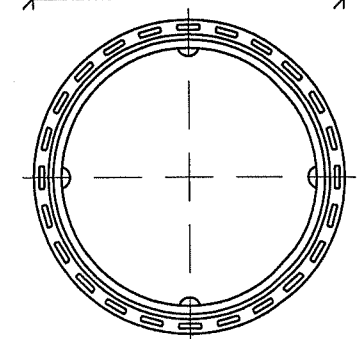
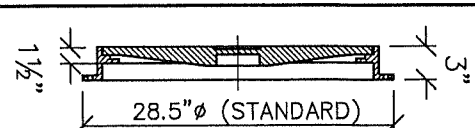
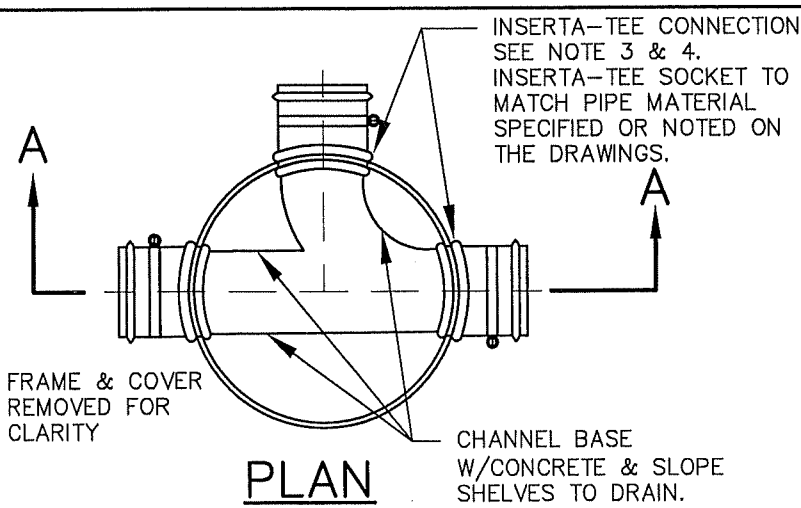

FRAME TO INCLUDE TABS THAT MATCH BASIN OD TO PREVENT DISPLACEMENT. FRAME BODY TO BEAR ON COMPACTED BASEROCK (SEE SECTION A-A)

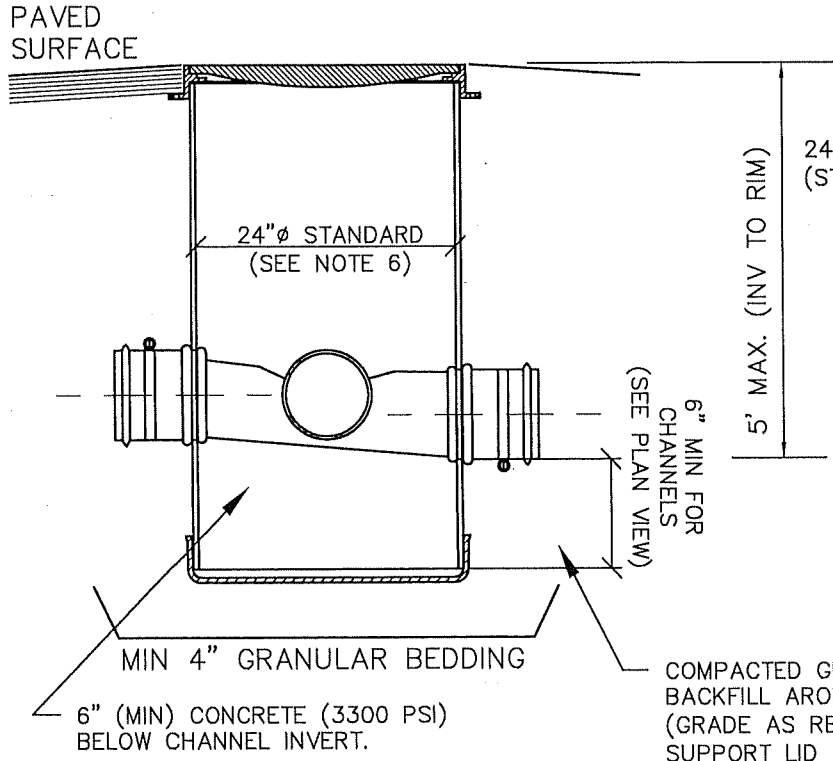

FRAME

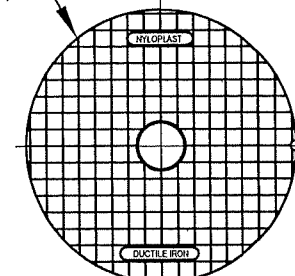

PROVIDE A MINIMUM OF (2) 1" DIAMETER PICK HOLES IN SOLID LID, OR PROVIDE STANDARD 16-HOLE STORM MANHOLE LID.

SOLID LID

NOTES:

1. NYLOPLAST TRAFFIC RATED DRAIN BASIN OR APPROVED EQUAL WITH NYLOPLAST FRAME & MH LID.
2. MH FRAME & COVER TO BE DUCTILE IRON PER ASTM A536 GRADE 70-50-05.
3. SEE CONSTRUCTION DRAWINGS FOR PIPE SIZE, LOCATION, ORIENTATION AND INVERT ELEVATIONS.
4. CONNECTIONS TO PVC MANHOLE TO BE INSERTA-TEE STYLE FITTINGS (FACTORY OR FIELD INSTALLED).
5. FIVE (5) FOOT MAXIMUM ALLOWABLE DEPTH FROM RIM TO OUTLET INVERT (DEEPER APPLICATIONS REQUIRE 48" MANHOLE).
6. MAXIMUM NUMBER & CONFIGURATION OF PIPE CONNECTIONS TO BE BASED ON INSERTA-TEE RECOMMENDATIONS. PROVIDE 30" DIAMETER BASIN & 30" SOLID COVER IF REQUIRED DUE TO NO. OF PIPES, SPACING &/OR ANGLES (30" MH TO MEET ALL DETAIL REQUIREMENTS SHOWN EXCEPT DIAMETER).

NOTE: PER ORS 92.044(7), MANHOLE MUST BE SET 1' MINIMUM CLEAR FROM ANY SURVEY MONUMENT

LAST REVISION DATE: FEB 2021	JO #
24" DIA. STORM MANHOLE (TRAFFIC RATED PVC W/SOLID DUCTILE IRON FRAME/COVER) (NTS)	
AUMSVILLE, OR	DETAIL NO. 351

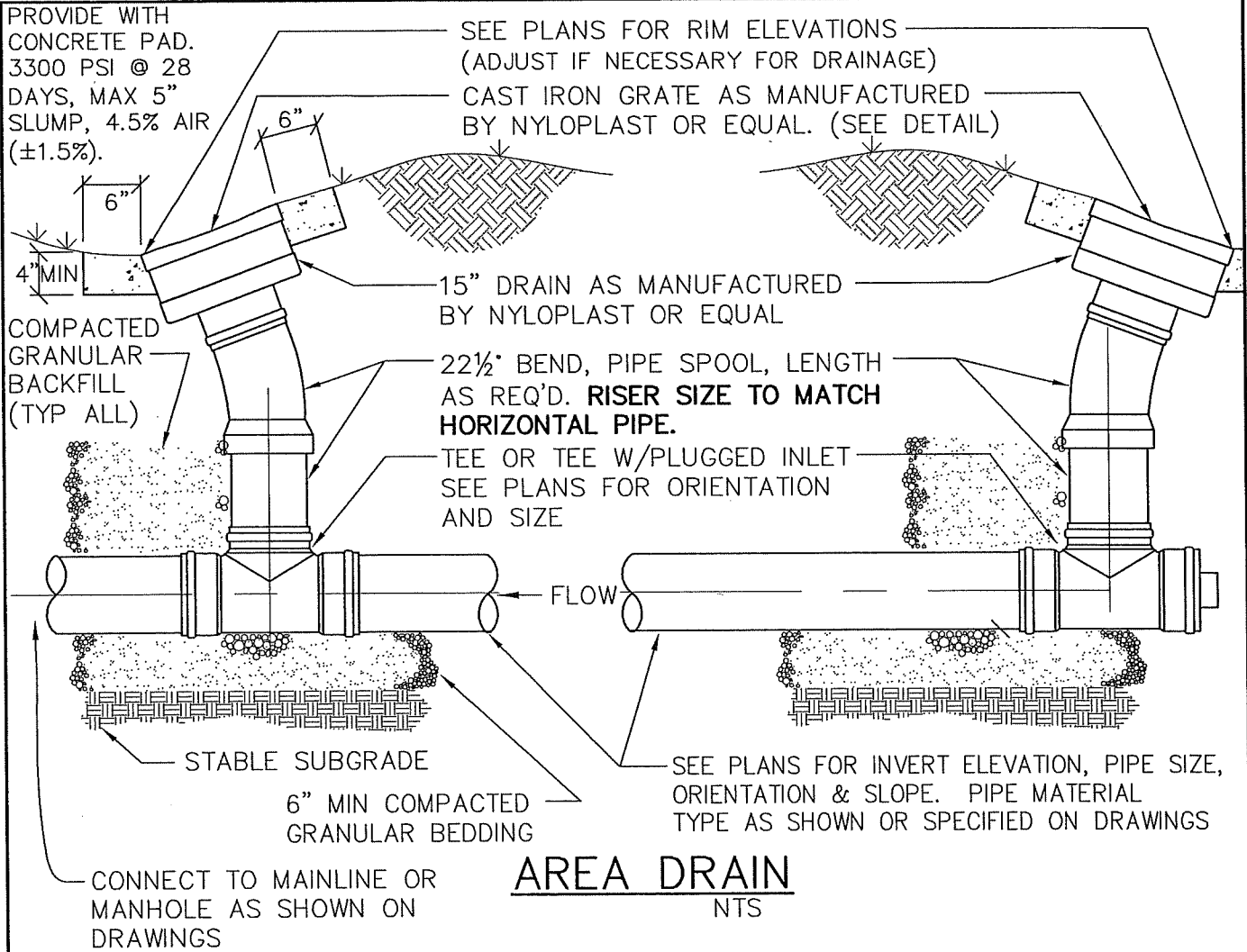

AREA DRAIN
NTS

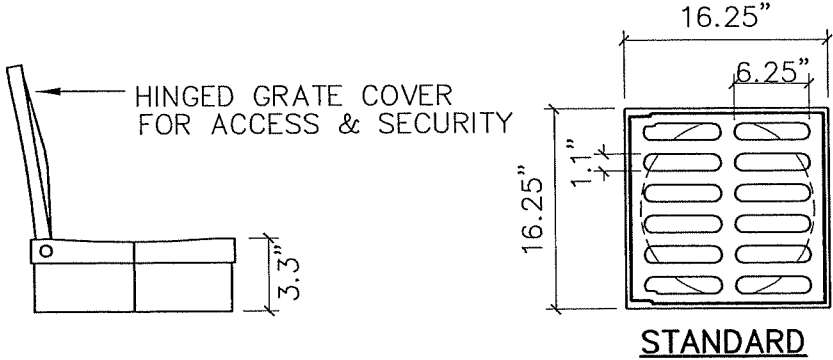

15" CAST IRON GRATE DETAIL
NTS

NOTES:

1. AREA DRAIN NOT FOR USE IN AREAS SUBJECT TO VEHICLE TRAFFIC.
2. USE WATERTIGHT GASKETED FITTINGS AND ADAPTORS FOR ALL PIPE CONNECTIONS.
3. ALTERNATE PRODUCTS OR CONFIGURATIONS PROPOSED SHALL INCLUDE SLANTED GRATE CONFIGURATION TO MINIMIZE GRATE BLIND-OFF BY LEAVES OR DEBRIS.
4. ANY GRATES SET IN SURFACED PEDESTRIAN AREAS SHALL CONFORM WITH ADA REQUIREMENTS, INCLUDING GRATE OPENING SIZE.

LAST REVISION DATE: JULY 2022	JO # STANDARD
PRIVATE AREA DRAIN, NON-TRAFFIC AREAS	
(NTS)	
AUMSVILLE, OR	DETAIL NO. 355

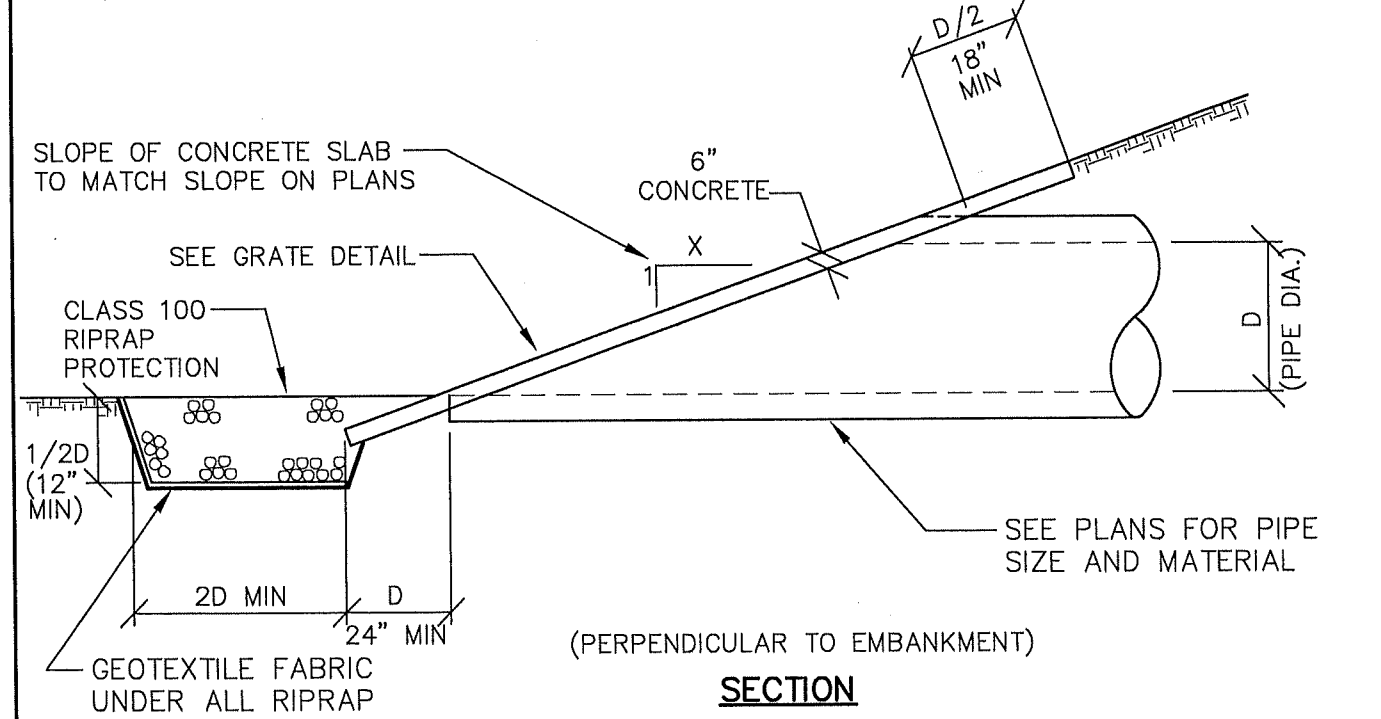
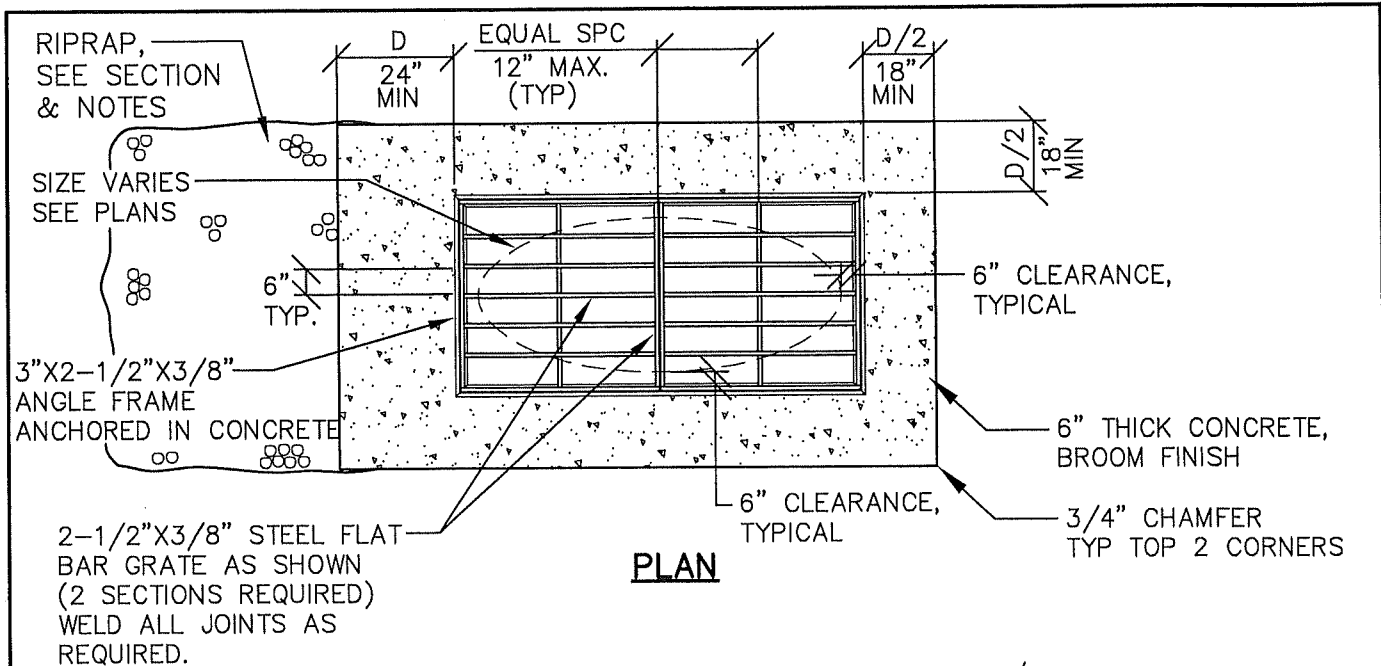

NOTES:

1. SEE CONSTRUCTION DRAWINGS FOR PIPE SIZE, LOCATION AND INVERT ELEVATION.
2. FRAME & GRATE SHALL BE ASTM A36 STEEL, HOT DIP GALVANIZED AFTER FABRICATION.
3. ALL CONCRETE TO BE 3300 PSI AT 28 DAYS, MAX 5" SLUMP, 4.5% AIR (±1.5%).
4. GRATED CONFIGURATION SHOWN IS TYPICALLY USED WHERE OUTFALL PIPE DISCHARGES THROUGH EMBANKMENT PERPENDICULAR TO THE DRAINAGE CHANNEL, AND WHERE REQUIRED TO ACCOMMODATE BANK MOWING EQUIP.
5. USE NON-GRATED CONFIGURATION WHERE APPROVED BY PUBLIC WORKS DIRECTOR.
6. ARMORING OF FAR CHANNEL BANK (TO BANK TOP) IS REQUIRED UNLESS NO EROSION POTENTIAL EXISTS (AS DETERMINED BY CITY). ARMOR BOTTOM & BANK 10 FEET MINIMUM IN EACH DIRECTION FROM OUTFALL CENTERLINE, UNLESS FURTHER SHOWN ON DWGS.
7. FILL ALL VOIDS IN RIP-RAP WITH 3/4"-0 GRANULAR BASEROCK.

LAST REVISION DATE: SEPT 2021	
CONCRETE PIPE END CAP WITH GRATE (NTS)	
AUMSVILLE, OR	DETAIL NO. 362

FOR USE ONLY WHERE SPECIFICALLY APPROVED BY PUBLIC WORKS DIRECTOR AND CITY ENGINEER, BASED ON SOIL INFILTRATION TESTS PER PWDS 3.20..

PROPERTY LINE

SLOPE OF LAND NOT TO EXCEED 10%

LEACH LINE
(SEE DTL 370B)
(SLOPE AWAY FROM TRASH TRAP)

NOTES:

1. DESIGN LEACH LINE LENGTH DEPENDENT ON SITE INFILTRATION TESTS RESULTS (50' MIN. LENGTH), INSTALL AT 1% MIN, 3% MAX SLOPE, (INSTALL PERPENDICULAR TO SLOPE OF LAND, PARALLEL WITH CONTOURS).
2. LEACH LINE MUST BE REGISTERED AS A UIC (UNDERGROUND INJECTION CONTROL) WITH DEQ, UNLESS REGISTRATION REQUIREMENT WAIVED IN WRITING BY DEQ.
3. MAX IMPERVIOUS AREA TO BE SERVED BY LEACH LINE IS 10,000 SF.

TRASH TRAP
(SEE DTL 370B FOR MINIMUM SIZE/CONFIGURATION)

SAMPLE ELEVATION CONTOURS

ROOF DRAIN

HOUSE

PROPERTY LINE

STREET

LAST REVISION DATE:

FEB 2021

ROOF DRAIN TRASH TRAP & LEACH LINE PLAN

(NTS)

DETAIL NO.

AUMSVILLE, OR

370A

750'

5' MIN.

5' MIN.

10' MIN.

755'

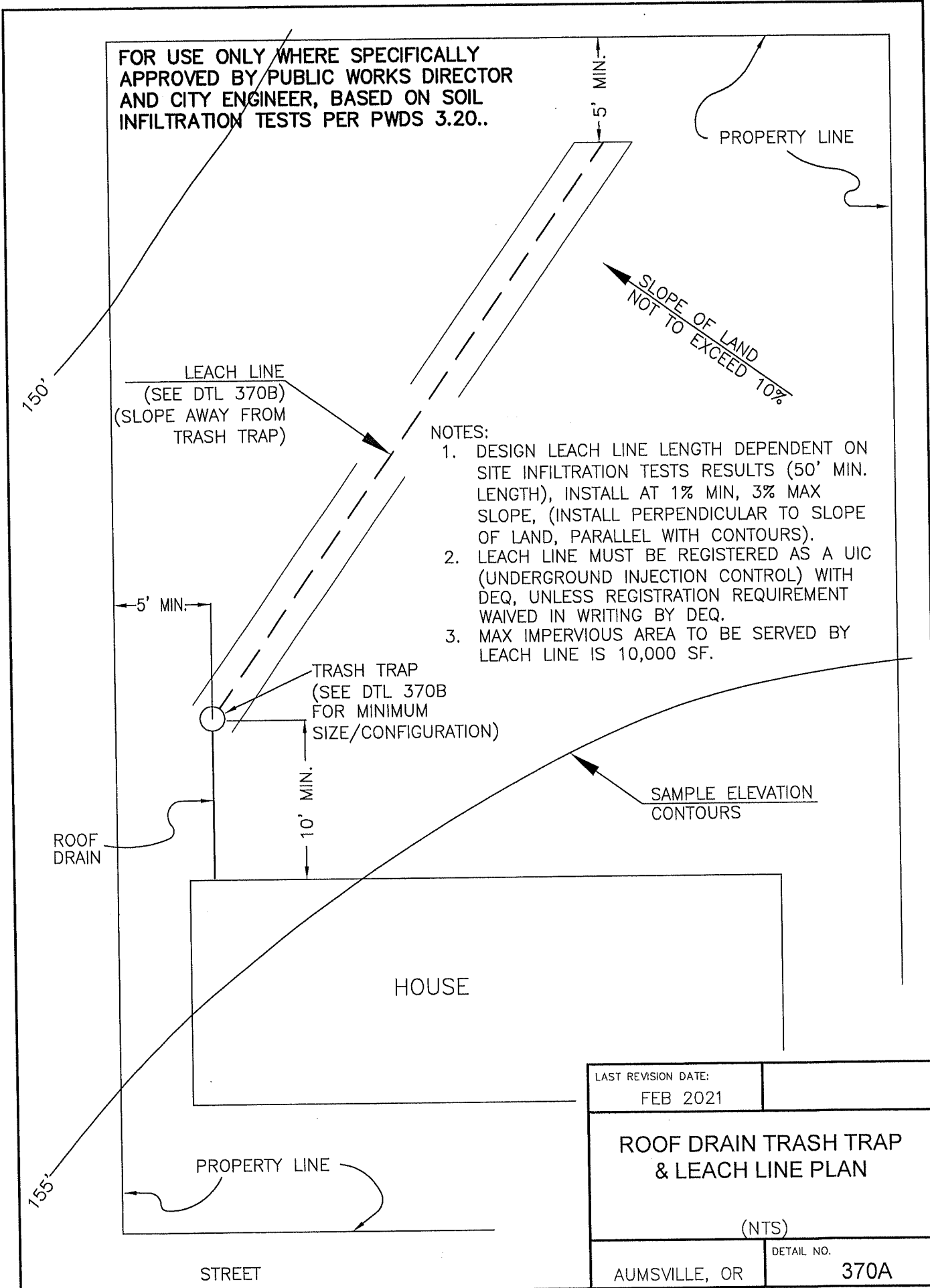

FOR USE ONLY WHERE SPECIFICALLY APPROVED BY
PUBLIC WORKS DIRECTOR AND CITY ENGINEER, BASED
ON SOIL INFILTRATION TESTS PER PWDS 3.20..

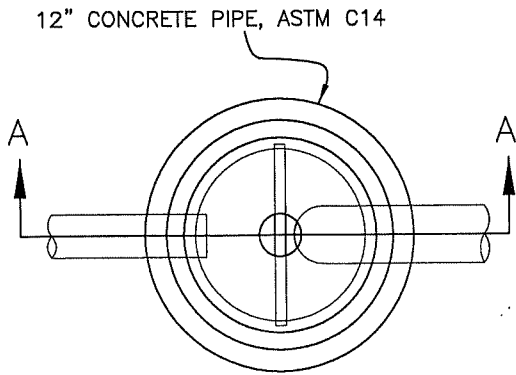

TRASH TRAP

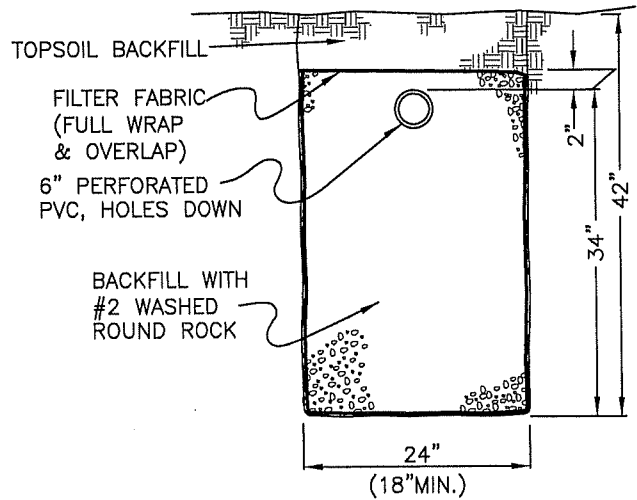

TYPICAL SECTION
LEACH LINE
(SEE NOTES FOR
OPTIONS)

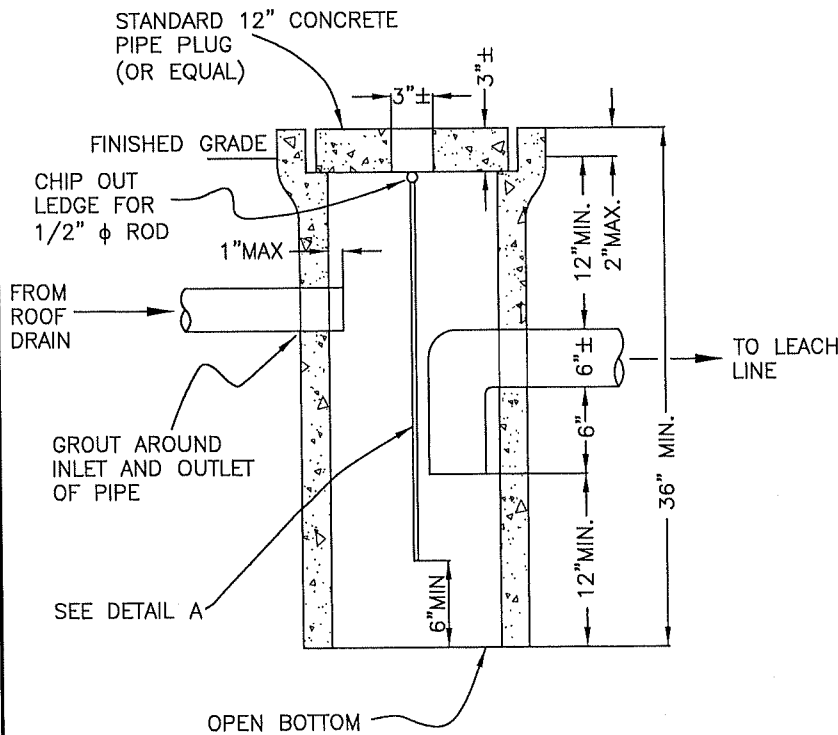

SECTION A-A

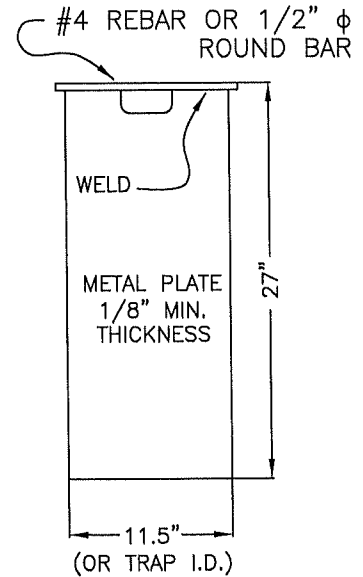

DETAIL A

NOTES:

- TRASH TRAP SIZE SHOWN IS MINIMUM REQUIRED BY CITY PW STANDARDS. OPSC REQUIREMENTS MAY ALSO APPLY. LARGER TRAPPED BASIN IS RECOMMENDED FOR EASE OF MAINTENANCE & CLEANING.
- EZflow DRAINAGE SYSTEM by INFILTRATOR (OR EQUAL) IS ALLOWED AS AN OPTION TO WASHED ROCK TRENCH SHOWN (15" MIN BUNDLE W/PIPE).

LAST REVISION DATE:	
FEB 2021	
TRASH TRAP & LEACH LINE DETAILS	
(NTS)	
AUMSVILLE, OR	DETAIL NO. 370B

STORM SEWER MANDREL TEST REPORT

Project Location: (City)	Project Name:
Inspector: (Print)	Date: (Separate Report Required for Each Test Session)
Mandrel Diameters Verified? Yes / No	

Station (& Manhole #)		Size & Material	Length (ft)	Results	Backfill Compaction Completed?	Date Sewer Flushed & Cleaned	Comments
From	To						
				Pass / Fail	Yes / No		
				Pass / Fail	Yes / No		
				Pass / Fail	Yes / No		
				Pass / Fail	Yes / No		
				Pass / Fail	Yes / No		
				Pass / Fail	Yes / No		
				Pass / Fail	Yes / No		
				Pass / Fail	Yes / No		
				Pass / Fail	Yes / No		
				Pass / Fail	Yes / No		
				Pass / Fail	Yes / No		
				Pass / Fail	Yes / No		
				Pass / Fail	Yes / No		
				Pass / Fail	Yes / No		
				Pass / Fail	Yes / No		
				Pass / Fail	Yes / No		
				Pass / Fail	Yes / No		
				Pass / Fail	Yes / No		

1. Mandrel testing shall be conducted on a manhole to manhole (or cleanout) basis and shall be done after the line has been completely flushed out with water.
2. Mandrel testing shall be conducted after trench backfill and compaction has been completed.
3. The mandrel diameter shall be 95% of the pipe initial inside diameter. The inspector shall verify the diameter of each mandrel used during each test session.

NOTE: PER ORS 92.044(7), MANHOLE MUST BE SET 1' MINIMUM CLEAR FROM ANY SURVEY MONUMENT

PROVIDE GASKETED PVC CAP ON ALL STUBS FOR FUTURE CONNECTION SHOWN ON DWGS (EXTEND PIPE 2' MIN BEYOND MH WALL), SLOPE PER DWGS.

9" WIDE EXTERNAL MASTIC WRAP @ ALL JOINTS & PICKHOLES (TRELLEBORG BIDCO) ALL SS MHS

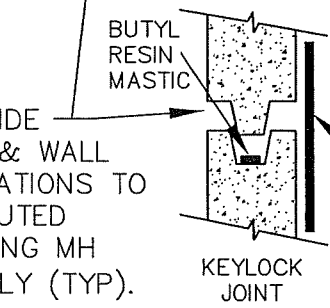
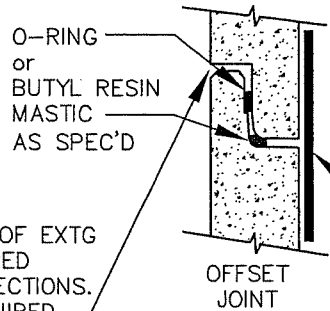
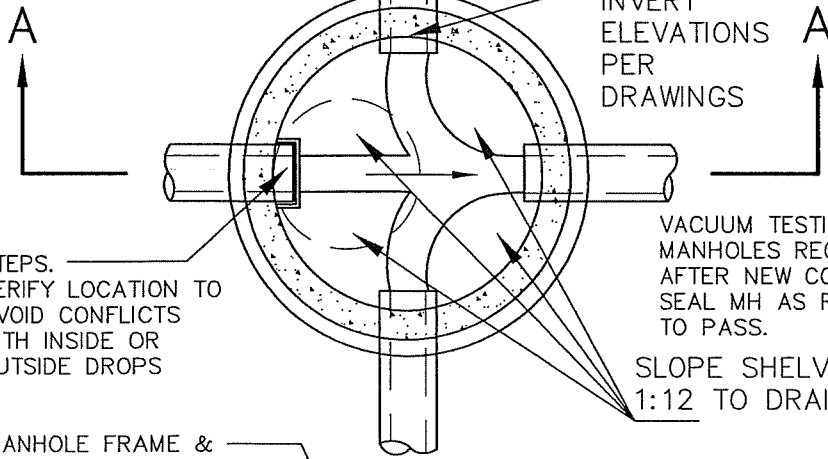

MANHOLE BARREL JOINT OPTIONS

STEPS. VERIFY LOCATION TO AVOID CONFLICTS WITH INSIDE OR OUTSIDE DROPS

MANHOLE FRAME & COVER, SET PER DTL 407

MANPAN MH LID INSERT AS REQ'D (SEE DTL 407) PAVED SURFACE

PLAN

SET FRAME IN NON-SHRINK GROUT

ALL INSIDE JOINTS & WALL PENETRATIONS TO BE GROUTED FOLLOWING MH ASSEMBLY (TYP).

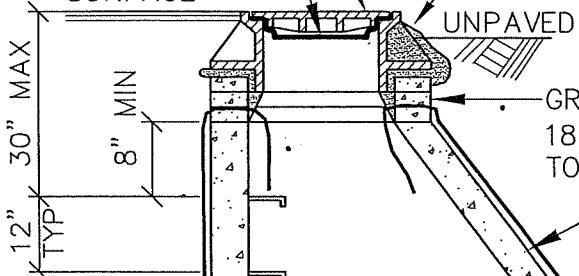

FLAT TOP MH'S SHALL BE USED FOR ALL MH'S LESS THAN 6' RIM TO INVERT, OR WITH TOP OF PIPE CONNECTIONS WITHIN 5 FEET OF RIM ELEV

ALL PIPE PENETRATIONS ON SANITARY SEWER MANHOLES TO HAVE RUBBER BOOTS AS SPECIFIED.

ROUTE TONING WIRE UP OUTSIDE OF MH AS SHOWN (TYP ALL PIPES).

NOTES:

1. PRECAST SECTIONS SHALL MEET OR EXCEED ASTM C-478. ALL CHANNELS & GROUTING TO BE SMOOTH.
2. WATERTIGHT O-RING OR MASTIC JOINTS REQUIRED, W/EXTERNAL SEAL AT BARREL JOINTS & PICKHOLES.
3. STEPS TO BE POLYPROPYLENE PLASTIC WITH GRADE 60 REINFORCING ROD. ADD STEPS TO EXTG CONNECTION MH IF EXTG STEPS ARE ABSENT.

LAST REVISION DATE: AUG 2022

COPYRIGHT 1996 WESTECH ENGINEERING, INC.

STANDARD MANHOLE FOR 21" PIPE AND SMALLER (SEWER & STORM)

(NTS)

AUMSVILLE, OR

DETAIL NO. 401

NOTE: PER ORS 92.044(7), MANHOLE MUST BE SET 1' MINIMUM CLEAR FROM ANY SURVEY MONUMENT

PROVIDE GASKETED PVC CAP ON ALL STUBS FOR FUTURE CONNECTION SHOWN ON DWGS (EXTEND PIPE 2' MIN BEYOND MH WALL), SLOPE PER DWGS.

A

INVERT ELEVATIONS PER DRAWINGS

A

O-RING or BUTYL RESIN MASTIC AS SPEC'D

STEPS. VERIFY LOCATION TO AVOID CONFLICTS WITH INSIDE OR OUTSIDE DROPS

VACUUM TESTING OF EXTG MANHOLES REQUIRED AFTER NEW CONNECTIONS. SEAL MH AS REQUIRED TO PASS.

SLOPE SHELVES 1:12 TO DRAIN

OFFSET JOINT

BUTYL RESIN MASTIC

ALL INSIDE JOINTS & WALL PENETRATIONS TO BE GROUTED FOLLOWING MH ASSEMBLY (TYP).

KEYLOCK JOINT

PLAN

MANHOLE FRAME & COVER, SET PER DTL 407

MANPAN MH LID INSERT AS REQ'D (SEE DTL 407)

PAVED SURFACE

SET FRAME IN NON-SHRINK GROUT

MANHOLE BARREL JOINT OPTIONS

9" WIDE EXTERNAL MASTIC WRAP @ ALL JOINTS & PICKHOLES (TRELLEBORG BIDCO) ALL SS MHS

30" MAX
12" TYP

MASTIC WRAP AS SPEC'D

UNPAVED

GRADE RINGS (VARIABLE) 18" MAX.—TOP OF FLAT TOP TO RIM

FLAT TOP SECTION, 8" MIN THICKNESS

48" INSIDE DIA. MIN

5" MIN. THICK CHANNEL DEPTH = 2/3 PIPE DIA. MIN.

ALL PIPE PENETRATIONS ON SANITARY SEWER MANHOLES TO HAVE RUBBER BOOTS AS SPECIFIED.

ROUTE TONING WIRE UP OUTSIDE OF MH AS SHOWN (TYP ALL PIPES).

ALL OPENINGS CORED DRILLED.

16" MAX

FLOW

PRECAST BASE, 6" MIN THICKNESS

6" MIN COMPACTED GRANULAR BEDDING

18" MAX (CONC PIPE, TYP)

STABLE SUBGRADE

SECTION A-A

NOTES:

1. PRECAST SECTIONS SHALL MEET OR EXCEED ASTM C-478. ALL CHANNELS & GROUTING TO BE SMOOTH.
2. WATERTIGHT O-RING OR MASTIC JOINTS REQUIRED, W/EXTERNAL SEAL AT BARREL JOINTS & PICKHOLES.
3. STEPS TO BE POLYPROPYLENE PLASTIC WITH GRADE 60 REINFORCING ROD. ADD STEPS TO EXTG CONNECTION MH IF EXTG STEPS ARE ABSENT.

LAST REVISION DATE:

JULY 2022

COPYRIGHT 1998 WESTECH ENGINEERING, INC.

FLAT TOP MANHOLE FOR 21" PIPE AND SMALLER (SEWER & STORM)

(NTS)

DETAIL NO.

AUMSVILLE, OR

402

NOTE: PER ORS 92.044(7), MANHOLE MUST BE SET 1' MINIMUM CLEAR FROM ANY SURVEY MONUMENT

PROVIDE GASKETED PVC CAP ON ALL STUBS FOR FUTURE CONNECTION SHOWN ON DWGS (EXTEND PIPE 2' MIN BEYOND MH WALL), SLOPE PER DWGS. (THIS STUB NOT SHOWN BELOW)

A

A

O-RING or BUTYL RESIN MASTIC AS SPEC'D

VACUUM TESTING OF EXTG MANHOLES REQUIRED AFTER NEW CONNECTIONS. SEAL MH AS REQUIRED TO PASS.

SLOPE SHELVES 1:12 TO DRAIN

STEPS. VERIFY LOCATION TO AVOID CONFLICTS WITH INSIDE OR OUTSIDE DROPS

OFFSET JOINT

BUTYL RESIN MASTIC

ALL INSIDE JOINTS & WALL PENETRATIONS TO BE GROUTED FOLLOWING MH ASSEMBLY (TYP).

KEYLOCK JOINT

9" WIDE EXTERNAL MASTIC WRAP @ ALL JOINTS & PICKHOLES (TRELLEBORG BIDCO) ALL SS MHS

PLAN

MANHOLE FRAME & COVER, SET PER DTL 407

MANPAN MH LID INSERT AS REQ'D (SEE DTL 407)

PAVED SURFACE

SET FRAME IN NON-SHRINK GROUT

UNPAVED

MANHOLE BARREL JOINT OPTIONS

30" MAX
12" TYP

MASTIC WRAP AS SPEC'D

GRADE RINGS (VARIABLE) 18" MAX.-TOP OF FLAT TOP TO RIM

FLAT TOP SECTION, 8" MIN THICKNESS

60" INSIDE DIA. MIN

FOR MANHOLES DEEPER THAN 11 FT. RIM TO INVERT, SEE DETAIL 403A

ALL OPENINGS CORED DRILLED

12" MIN.

5" MIN. THICK

ALL PIPE PENETRATIONS ON SANITARY SEWER MANHOLES TO HAVE RUBBER BOOTS AS SPECIFIED.

ROUTE TONING WIRE UP OUTSIDE OF MH AS SHOWN (TYP ALL PIPES).

CHANNEL DEPTH = 2/3 PIPE DIA. MIN.

PRECAST BASE, 8" MIN THICKNESS

STABLE SUBGRADE

6" MIN COMPACTED GRANULAR BEDDING

SECTION A-A

NOTES:

1. PRECAST SECTIONS SHALL MEET OR EXCEED ASTM C-478. ALL CHANNELS & GROUTING TO BE SMOOTH.
2. WATERTIGHT O-RING OR MASTIC JOINTS REQUIRED, W/EXTERNAL SEAL AT BARREL JOINTS & PICKHOLES.
3. STEPS TO BE POLYPROPYLENE PLASTIC WITH GRADE 60 REINFORCING ROD. ADD STEPS TO EXTG CONNECTION MH IF EXTG STEPS ARE ABSENT.

LAST REVISION DATE: JULY 2022	COPYRIGHT 1996 WESTECH ENGINEERING, INC.
MANHOLE FOR 24" AND 27" PIPE (SEWER & STORM) (NTS)	
AUMSVILLE, OR	DETAIL NO. 403

PROVIDE GASKETED PVC CAP ON ALL STUBS FOR FUTURE CONNECTION SHOWN ON DWGS (EXTEND PIPE 2' MIN BEYOND MH WALL), SLOPE PER DWGS.

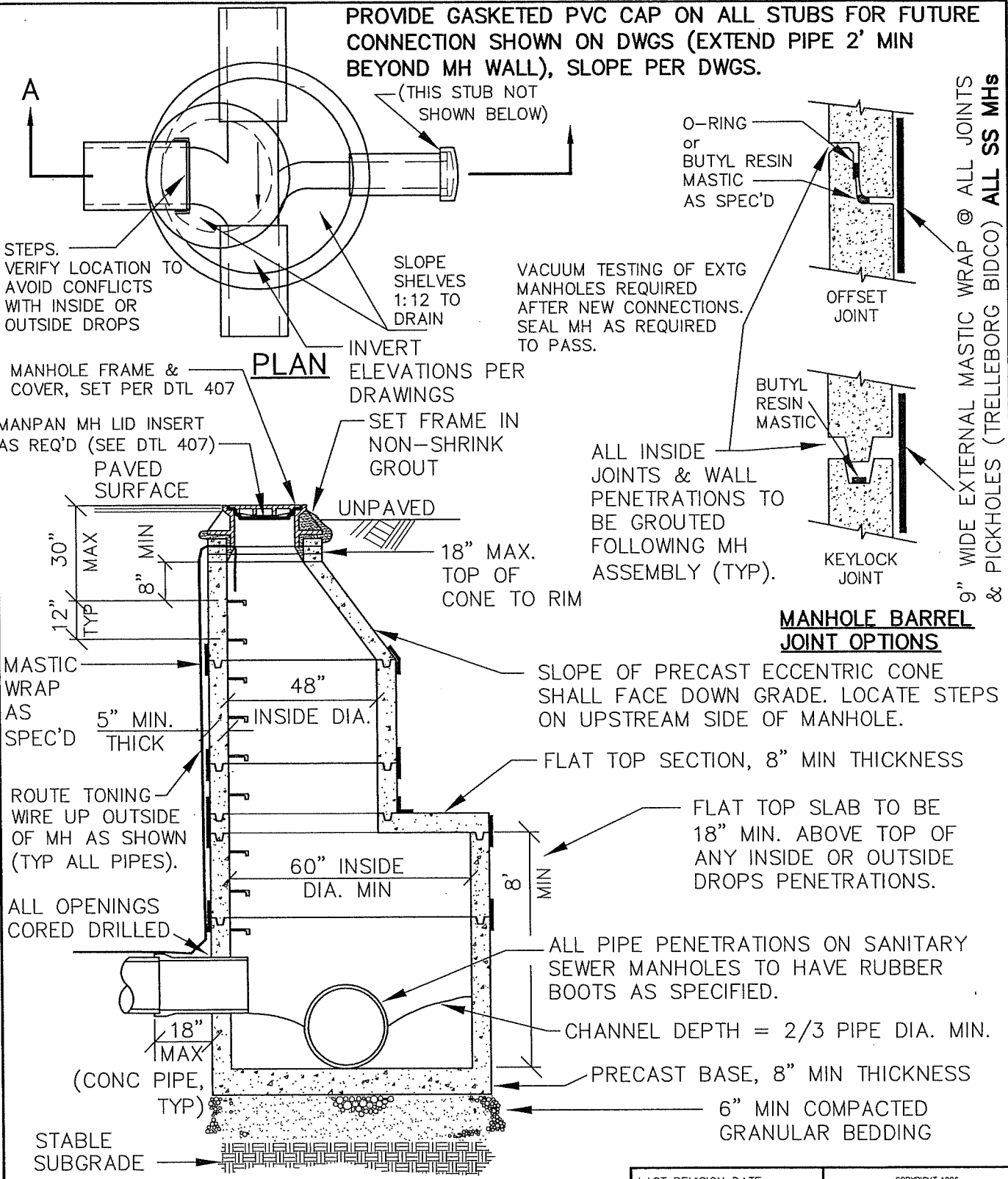

STEPS. VERIFY LOCATION TO AVOID CONFLICTS WITH INSIDE OR OUTSIDE DROPS

(THIS STUB NOT SHOWN BELOW)

SLOPE SHELVES 1:12 TO DRAIN

VACUUM TESTING OF EXTG MANHOLES REQUIRED AFTER NEW CONNECTIONS. SEAL MH AS REQUIRED TO PASS.

O-RING or BUTYL RESIN MASTIC AS SPEC'D

OFFSET JOINT

BUTYL RESIN MASTIC

ALL INSIDE JOINTS & WALL PENETRATIONS TO BE GROUTED FOLLOWING MH ASSEMBLY (TYP).

KEYLOCK JOINT

9" WIDE EXTERNAL MASTIC WRAP @ ALL JOINTS & PICKHOLES (TRELLEBORG BIDCO) ALL SS MHS

PLAN

MANHOLE BARREL JOINT OPTIONS

MANHOLE FRAME & COVER, SET PER DTL 407

INVERT ELEVATIONS PER DRAWINGS

MANPAN MH LID INSERT AS REQ'D (SEE DTL 407)

SET FRAME IN NON-SHRINK GROUT

PAVED SURFACE

UNPAVED

18" MAX. TOP OF CONE TO RIM

30" MAX
12" TYP
8" MIN

MASTIC WRAP AS SPEC'D 5" MIN. THICK

48" INSIDE DIA.

SLOPE OF PRECAST ECCENTRIC CONE SHALL FACE DOWN GRADE. LOCATE STEPS ON UPSTREAM SIDE OF MANHOLE.

FLAT TOP SECTION, 8" MIN THICKNESS

ROUTE TONING WIRE UP OUTSIDE OF MH AS SHOWN (TYP ALL PIPES).

FLAT TOP SLAB TO BE 18" MIN. ABOVE TOP OF ANY INSIDE OR OUTSIDE DROPS PENETRATIONS.

ALL OPENINGS CORED DRILLED

60" INSIDE DIA. MIN

ALL PIPE PENETRATIONS ON SANITARY SEWER MANHOLES TO HAVE RUBBER BOOTS AS SPECIFIED.

CHANNEL DEPTH = 2/3 PIPE DIA. MIN.

18" MAX (CONC PIPE, TYP)

PRECAST BASE, 8" MIN THICKNESS

6" MIN COMPACTED GRANULAR BEDDING

STABLE SUBGRADE

SECTION A-A

NOTES:

1. PRECAST SECTIONS SHALL MEET OR EXCEED ASTM C-478. ALL CHANNELS & GROUTING TO BE SMOOTH.
2. WATERTIGHT O-RING OR MASTIC JOINTS REQUIRED, W/EXTERNAL SEAL AT BARREL JOINTS & PICKHOLES.
3. STEPS TO BE POLYPROPYLENE PLASTIC WITH GRADE 60 REINFORCING ROD. ADD STEPS TO EXTG CONNECTION MH IF EXTG STEPS ARE ABSENT.

LAST REVISION DATE: JULY 2022	COPYRIGHT 1996 WESTECH ENGINEERING, INC.
DEEP MANHOLE FOR 24" AND 27" PIPE (SEWER & STORM) (NTS)	
AUMSVILLE, OR	DETAIL NO. 403A

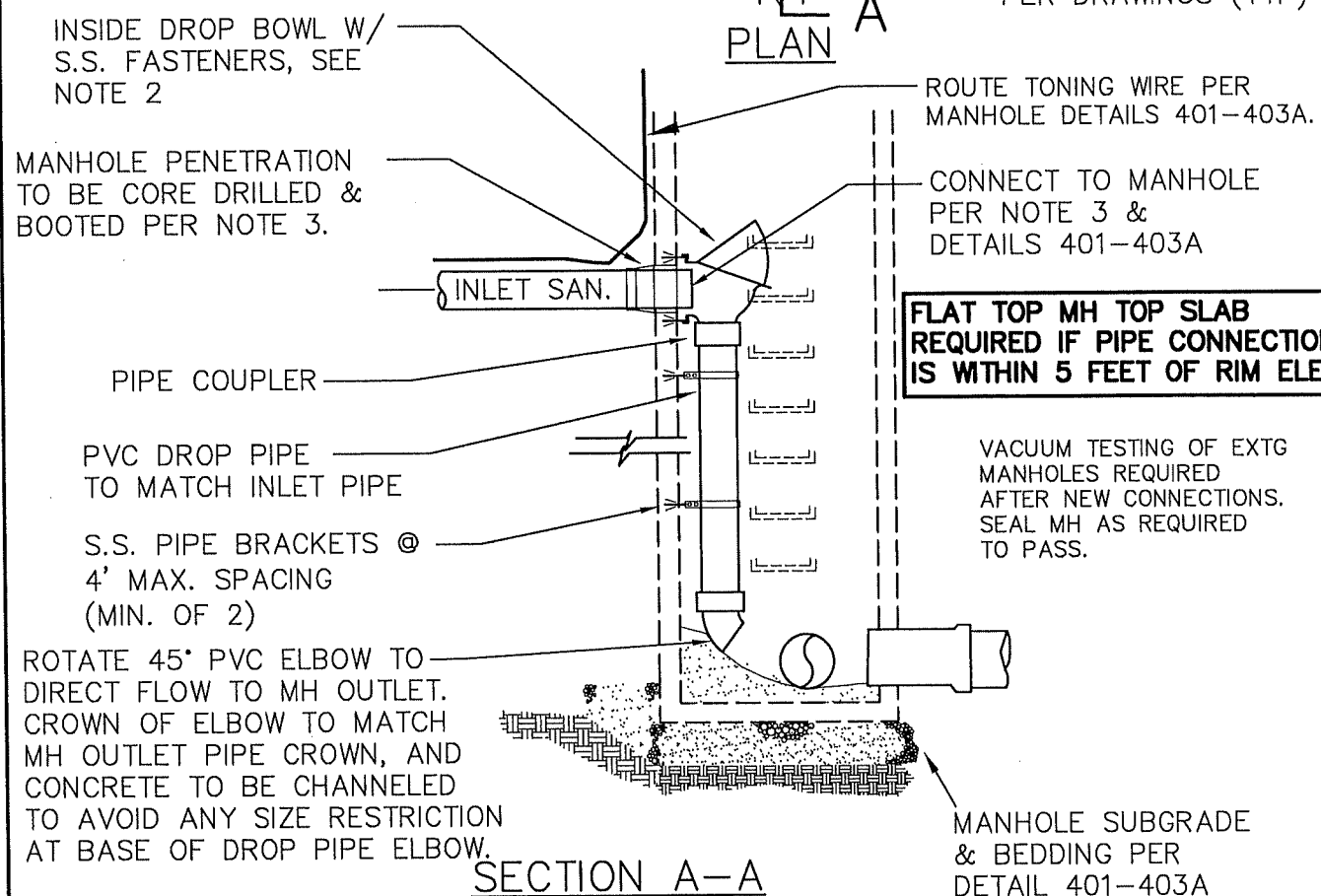
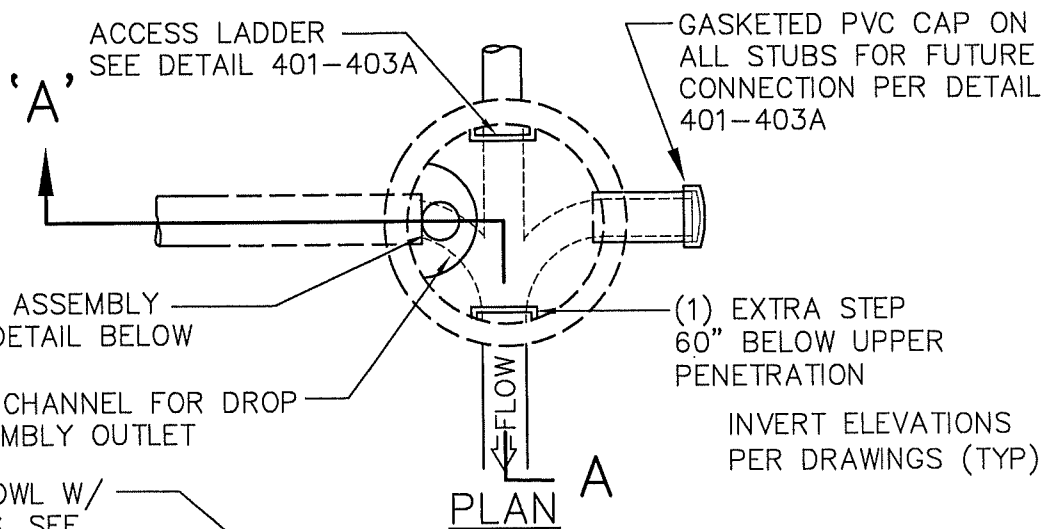

SECTION A-A

NOTES:

1. ALL INSIDE DROPS MUST BE APPROVED ON A CASE BY CASE BASIS BY THE PUBLIC WORKS DIRECTOR. MINIMUM 60" DIAMETER MANHOLE REQUIRED FOR INSIDE DROPS UNLESS OTHERWISE APPROVED IN WRITING BY THE PUBLIC WORKS DIRECTOR.
2. PROVIDE "RELINER" INSIDE DROP BOWL BY DURAN, INC. OR APPROVED EQUAL. WHERE NOTED ON DRAWINGS, FOR INLET PIPES WITH SLOPES GREATER THAN 5%, OR WHERE REQUIRED BY PUBLIC WORKS, PROVIDE BOWL WITH OPTIONAL HOOD AS SHOWN.
3. ALL PIPE PENETRATIONS SHALL HAVE RUBBER BOOTS. MANHOLE BASE, BARREL & TOP TO CONFORM WITH DETAILS 401-403A.

4. STEPS TO BE POLYPROPYLENE PLASTIC WITH GRADE 60 REINFORCING ROD. ADD STEPS TO EXTG CONNECTION MH IF EXTG STEPS ARE ABSENT.

LAST REVISION DATE: JULY 2021	
INSIDE DROP CONNECTION FOR SANITARY SEWER OR STORM MANHOLE	
(NTS)	
AUMSVILLE, OR	DETAIL NO. 404

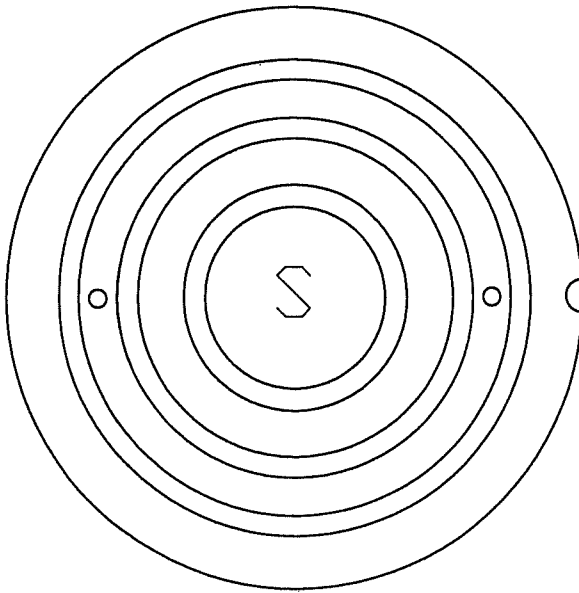

SANITARY

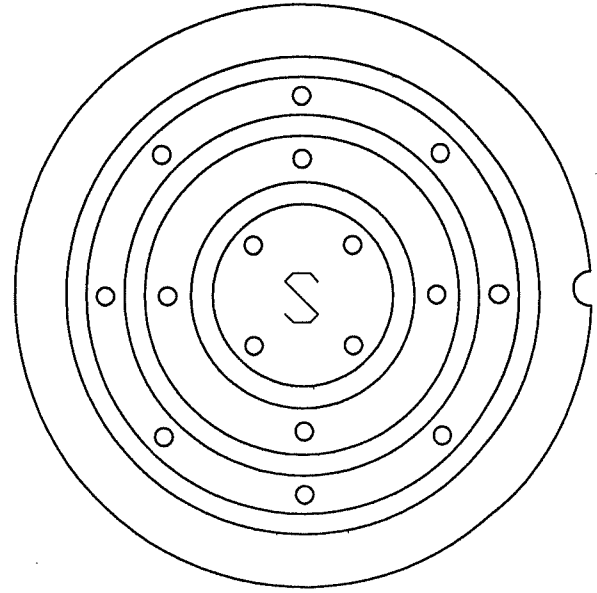

STORM

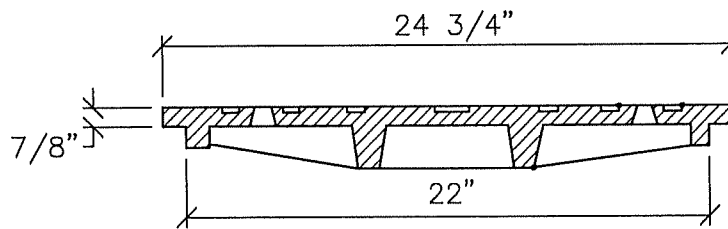

8 EA. -1/2" RIBS
EQUALLY SPACED

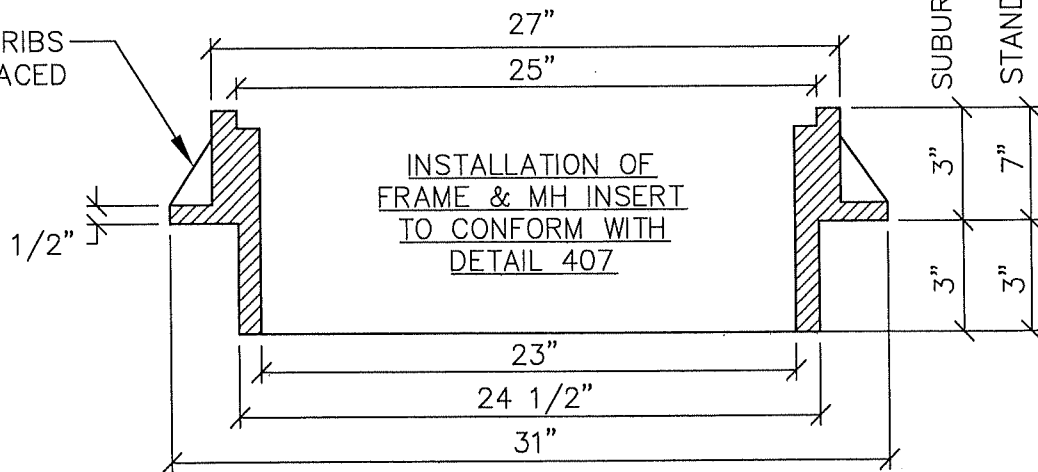

NOTES:

1. COVER AND FRAME SHALL BE GRAY CAST IRON
ASTM A-48, CLASS 30.
2. COVER AND FRAME TO BE MACHINED TO A TRUE
BEARING ALL AROUND.
3. NOTCH LID FOR LIFTING HOOK.

LAST REVISION DATE:

FEB 2021

**MANHOLE FRAME AND COVER
(STANDARD AND SUBURBAN)**

(NTS)

DETAIL NO.

AUMSVILLE, OR

405

SLOT FOR SCREWDRIVER

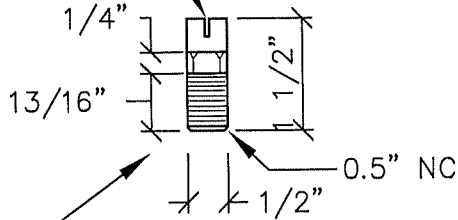

LOCATING STUD,
DRILL 25/64" HOLE
& TAP FOR 1/2" STUD
(ONE PER COVER)

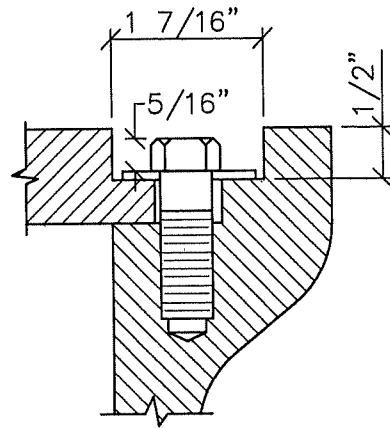
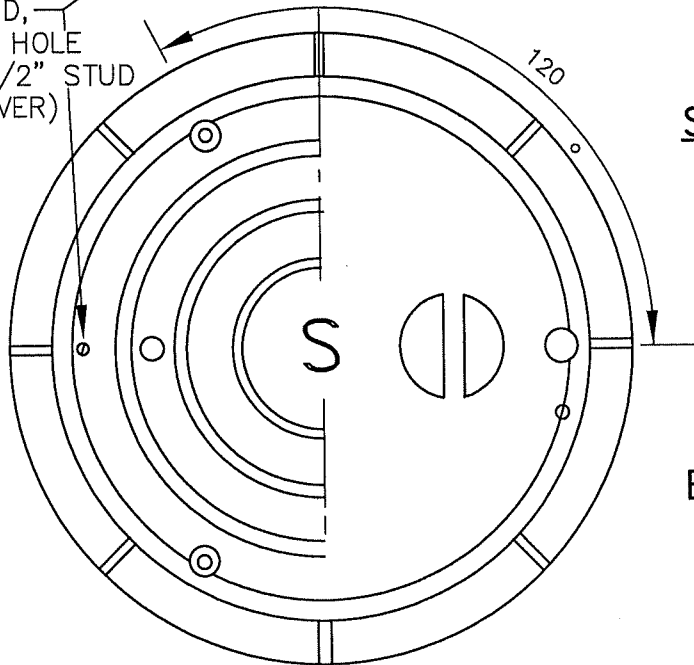

SECTION B-B

1/2"-13NCx1"
STAINLESS STEEL
HEX HEAD
CAP SCREW

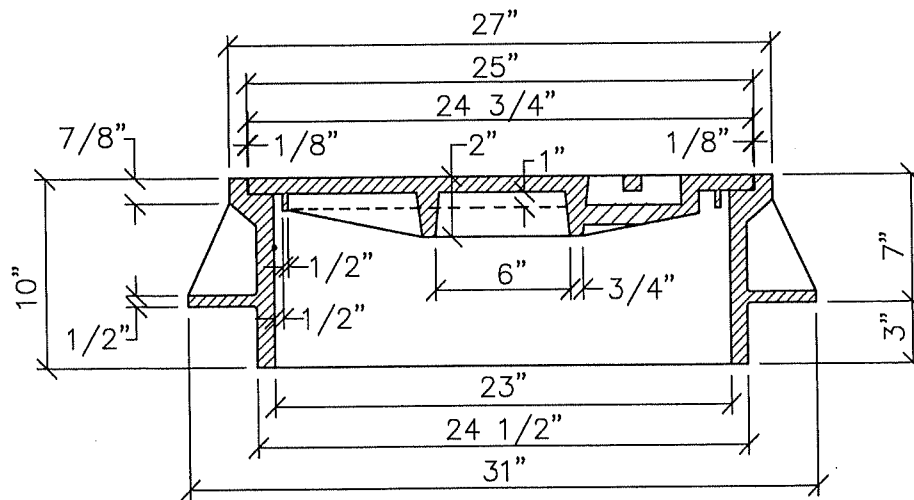
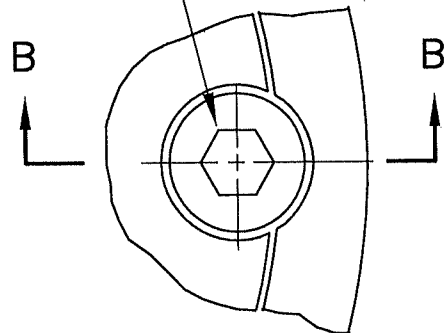

SECTION A-A

INSTALLATION OF
FRAME & MH INSERT
TO CONFORM WITH
DETAIL 407

NOTES:

1. COVER AND FRAME TO BE MACHINED TO A TRUE BEARING ALL AROUND.
2. MATERIAL SHALL BE OF GRAY CAST IRON, ASTM A-48, CLASS 30.
3. **LOCKDOWN FRAME & COVER SHALL BE USED ONLY WHERE SPECIFICALLY REQUIRED BY PUBLIC WORKS.**

LAST REVISION DATE: FEB 2021	
LOCKDOWN MANHOLE FRAME AND COVER	
(NTS)	
AUMSVILLE, OR	DETAIL NO. 406

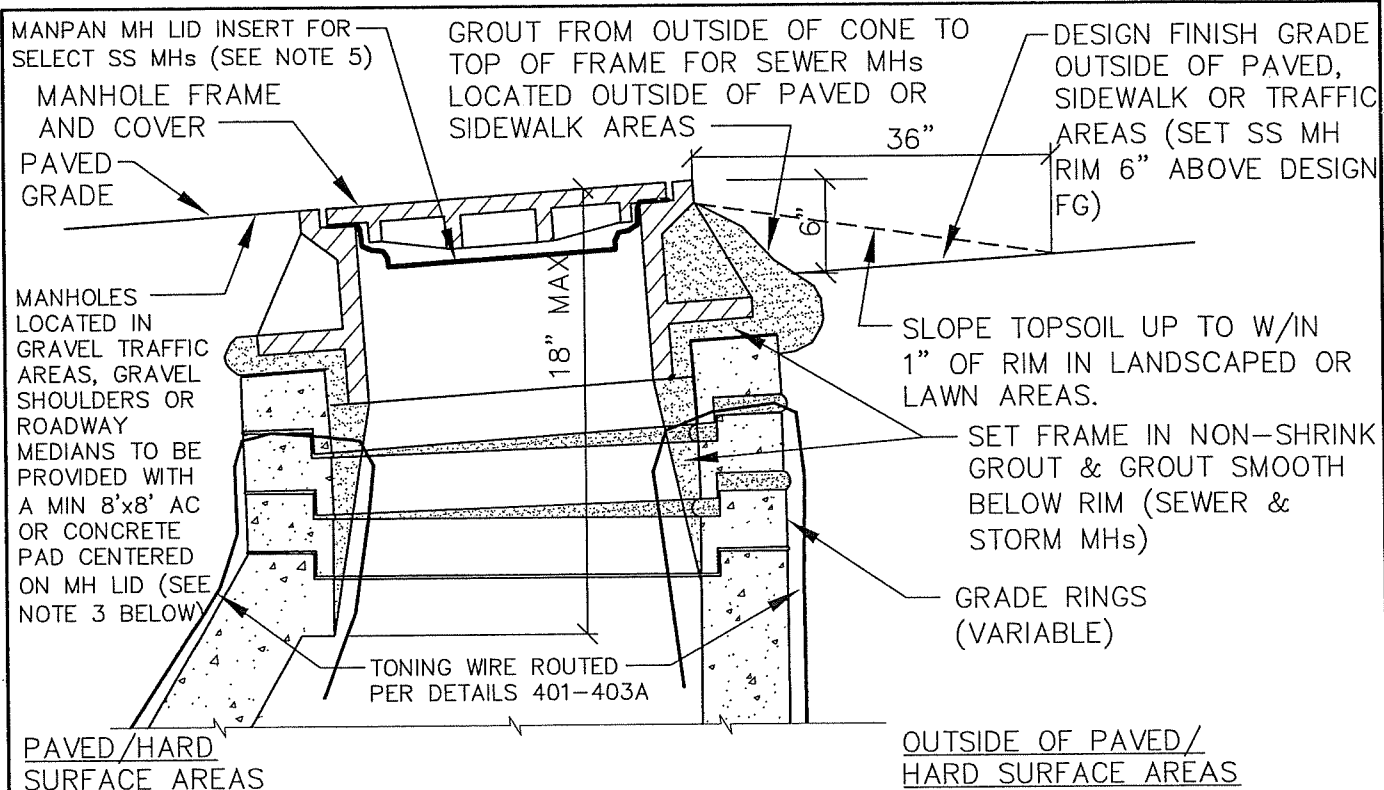

TYPICAL MANHOLE GRADE ADJUSTMENT

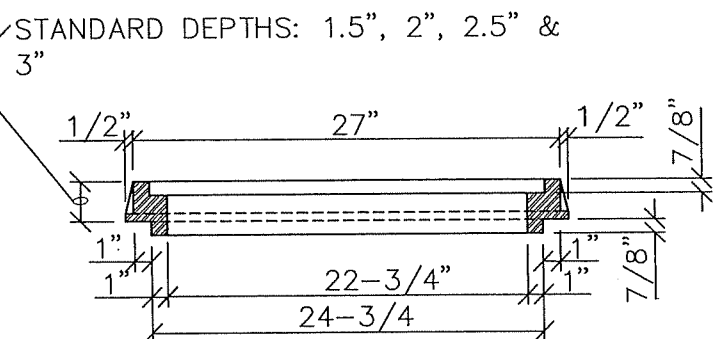
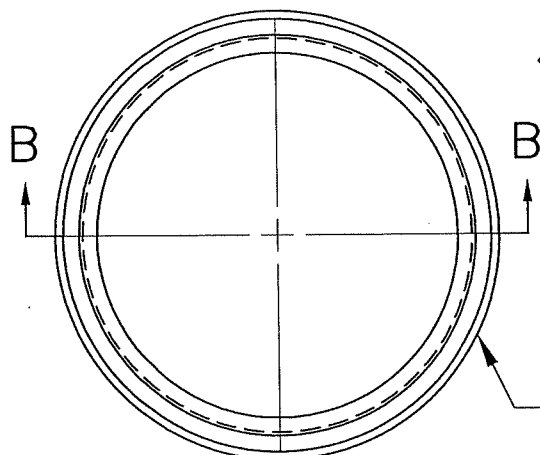

SECTION B-B

CAST IRON ADJUSTMENT RINGS

MANHOLE ADJUSTMENT RINGS FOR RESURFACING ONLY

NOTES:

1. CAST IRON ADJUSTMENT RINGS ALLOWED ONLY WITH OVERLAYS AND **NOT ON NEW MANHOLES**. MAXIMUM 1. ADJUSTMENT RING PER MANHOLE.
2. SANITARY SEWER MHs - 2 HOLE LIDS
STORM DRAIN MHs - 16 HOLE LIDS
3. MH PADS IN UNPAVED TRAFFIC AREAS (OR FLOW CONTROL MH) - 8'x8' MIN SIZE OF (A) 3" MIN. AC OVER 10" COMPACTED BASEROCK (OR PUBLIC ROAD STANDARD THICKNESS IF LOCATED IN R.O.W), OR (B) 8" CONCRETE OVER 2" BACKROCK.
4. MH PADS IN ROAD MEDIAN PLANTER AREAS - 4" CONC (PER DTL 212, 10' MIN SQUARE W/5' SCORING PATTERN).

5. SEWER MHs IN LOW AREAS SUBJECT TO FLOODING OR WATER PONDING, ADJACENT TO CURBLINES OR DITCHES, ETC. SHALL BE PROVIDED WITH INFLOW PROTECTOR LID INSERTS (MAN PAN OR EQUAL). SEE CITY STANDARD CONSTRUCTION NOTES FOR LOCATION CRITERIA.

LAST REVISION DATE: AUG 2022	JO #
MANHOLE RIM ADJUSTMENT DETAILS (SEWER & STORM) (NTS)	
AUMSVILLE, OR	DETAIL NO. 407

CLEANOUT COVERS: ALL SEWER CLEANOUT LIDS TO READ "SEWER"
 ALL STORM CLEANOUT LIDS TO READ "STORM" OR "C/O".

24" SQUARE CONCRETE PAD
 OR AC PAVEMENT OUTSIDE OF
 PAVED AREAS. SLOPE AWAY
 FROM CLEANOUT.

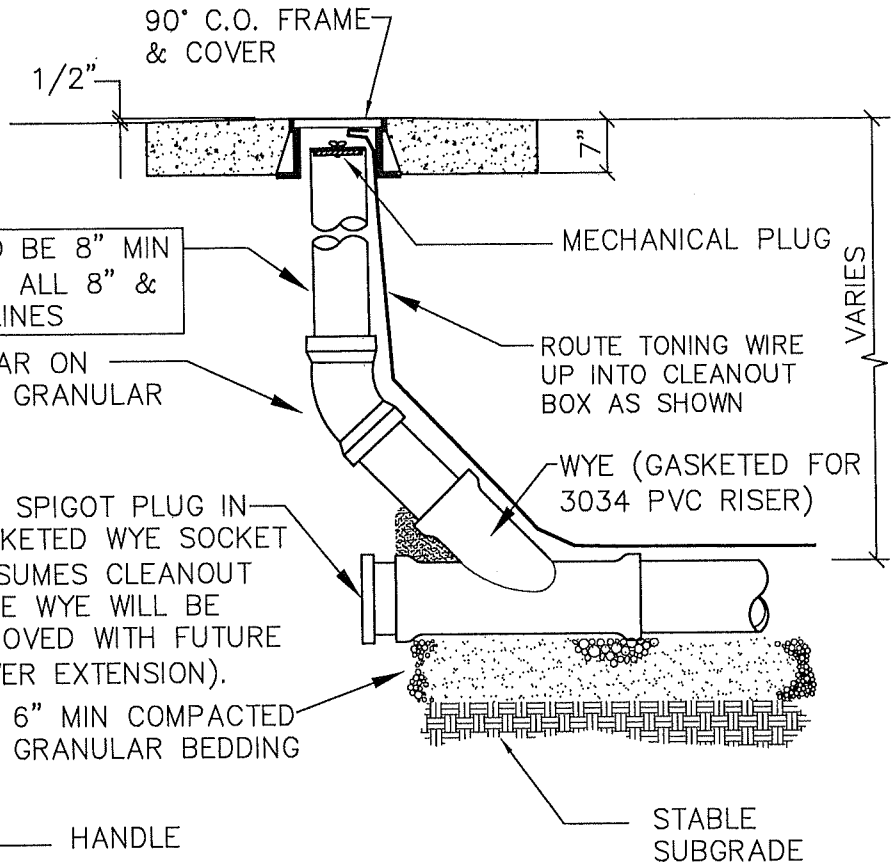
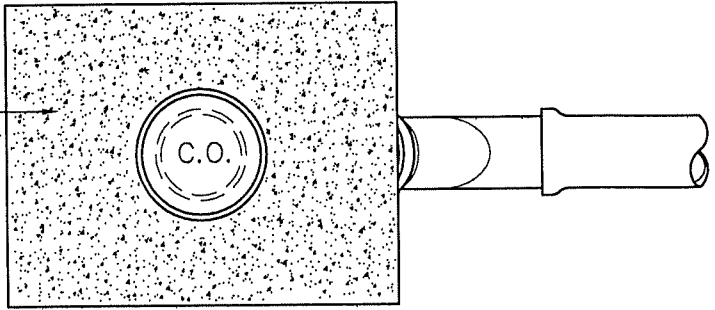

RISER PIPE TO BE 8" MIN
 DIAMETER FOR ALL 8" &
 LARGER MAINLINES

PIPE TO BEAR ON
 COMPACTED GRANULAR
 BACKFILL

PVC SPIGOT PLUG IN
 GASKETED WYE SOCKET
 (ASSUMES CLEANOUT
 BASE WYE WILL BE
 REMOVED WITH FUTURE
 SEWER EXTENSION).

6" MIN COMPACTED
 GRANULAR BEDDING

STABLE
 SUBGRADE

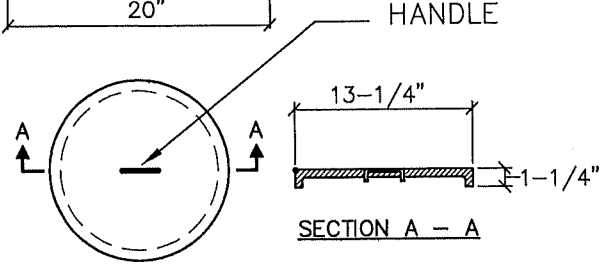
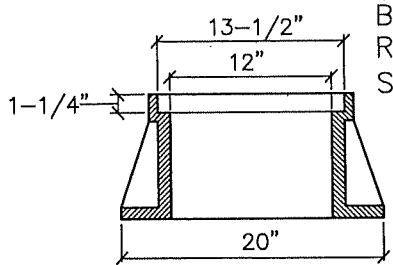

CLEANOUT FRAME & COVER

NOTES:

1. USE INLAND FOUNDRY MODEL 240 FRAME & COVER IN ALL AREAS.
2. COVER AND FRAME SHALL BE GRAY CAST IRON ASTM A-48, CLASS 30.
3. COVER AND FRAME TO BE MACHINED TO A TRUE BEARING ALL AROUND.

ALL CONCRETE SHALL BE 3300 PSI @ 28 DAYS, MAX 5" SLUMP, 4.5% AIR (±1.5%).

LAST REVISION DATE: FEB 2021	COPYRIGHT 1998 WESTECH ENGINEERING, INC.
MAINLINE CLEANOUT	
(NTS)	
AUMSVILLE, OR	DETAIL NO. 411

NOTE: NO VERTICAL OR HORIZONTAL PRESSURE TREATED 2" X 4" WIRE TO INVERT AND EXTENDING ABOVE FINISH GRADE. STAKE SHALL BE CONTINUOUS AND REMAIN VERTICAL AFTER WITHIN RIGHT-OF-WAY OR PUBLIC BACKFILLING. END SHALL BE PAINTED (WHITE FOR SEWER) (GREEN FOR STORM), AND LABELED WITH DEPTH TO PIPE BELOW GROUND SURFACE (2" BLOCK LETTERS). EXTEND TONING WIRE TO SURFACE. MAINLINE TO CLEANOUT).

NOTE: PER ORS 92.044(7), SERVICE LINES MUST BE SET 1' MINIMUM CLEAR FROM ANY SURVEY MONUMENT

NOTES:

1. MIN. 18" SEPARATION BETWEEN ADJACENT LATERALS.
2. ONE FULL LENGTH OF PVC PIPE (AT CROSSING) REQUIRED FOR ALL SEWER LATERALS WHICH CROSS UNDER WATER LINES WITH LESS THAN 18" MINIMUM VERTICAL CLEARANCE BETWEEN WATER LINE AND SERVICE LATERAL.
3. SERVICE SHALL NOT BE BACKFILLED PRIOR TO INSPECTION BY PUBLIC WORKS.
4. INSTALL A CONTINUOUS 12 GAUGE SOLID CORE GREEN INSULATED TRACER WIRE FROM MAINLINE WIRE TO END OF LATERAL.
5. CHIMNEY DROPS INTO MAINLINES ARE PROHIBITED.
6. **COMMERCIAL** SEWER & STORM SERVICE LATERALS SHALL BE 6-INCH MINIMUM DIAMETER.

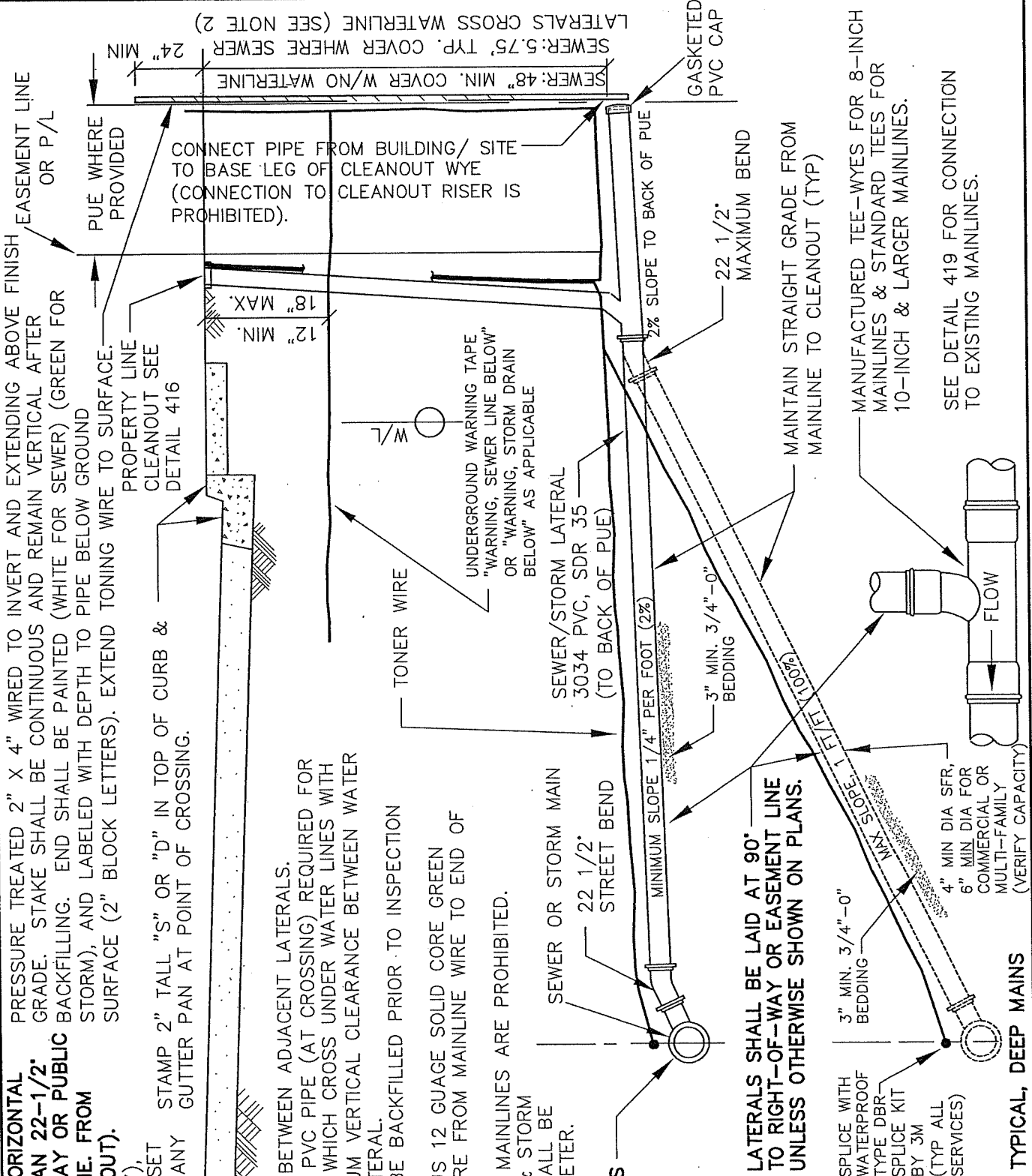

TYPICAL, SHALLOW MAINS

LAST REVISION DATE: JULY 2022	COPYRIGHT 1996 WESTECH ENGINEERING, INC.
SEWER AND STORM SERVICE LATERALS	
(NTS)	
AUMSVILLE, OR	DETAIL NO. 415

LATERALS SHALL BE LAID AT 90° TO RIGHT-OF-WAY OR EASEMENT LINE UNLESS OTHERWISE SHOWN ON PLANS.

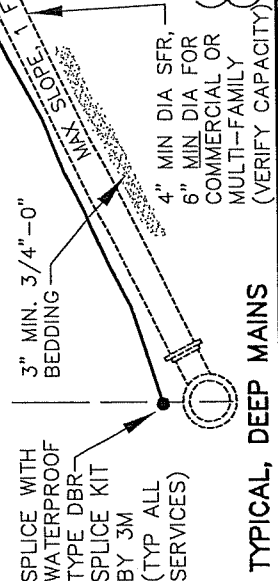

SEE DETAIL 419 FOR CONNECTION TO EXISTING MAINLINES.

MANUFACTURED TEE-WYES FOR 8-INCH MAINLINES & STANDARD TEES FOR 10-INCH & LARGER MAINLINES.

MAINTAIN STRAIGHT GRADE FROM MAINLINE TO CLEANOUT (TYP)

22 1/2" MAXIMUM BEND

2% SLOPE TO BACK OF PUE

SEWER/STORM LATERAL 3034 PVC, SDR 35 (TO BACK OF PUE)

UNDERGROUND WARNING TAPE "WARNING, SEWER LINE BELOW" OR "WARNING, STORM DRAIN BELOW" AS APPLICABLE

TONER WIRE

12" MIN.

18" MAX.

PROPERTY LINE CLEANOUT SEE DETAIL 416

PUE WHERE PROVIDED

EASEMENT LINE OR P/L

GASKETED PVC CAP

SEWER: 48" MIN. COVER W/NO WATERLINE
SEWER: 5.75" TYP. COVER WHERE SEWER LATERALS CROSS WATERLINE (SEE NOTE 2)

CLEANOUT COVERS: ALL SEWER CLEANOUT LIDS TO READ "SEWER"
 ALL STORM CLEANOUT LIDS TO READ "STORM" OR "C/O".

- NON-TRAFFIC AREAS:
 CARSON MODEL 910 T-COVER OR EQUAL (GREEN FOR SEWER, GREY FOR STORM).
- TRAFFIC AREAS, INCLUDING DRIVEWAYS:
 8" X 4" CAST IRON FRAME & COVER, OLYMPIC M1007 OR EQUAL.
 8" X 6" CAST IRON FRAME & COVER, OLYMPIC M1018 OR EQUAL.
 (FOR CI CLEANOUTS IN UNPAVED AREAS, SET IN 6" THICK CONCRETE PAD)

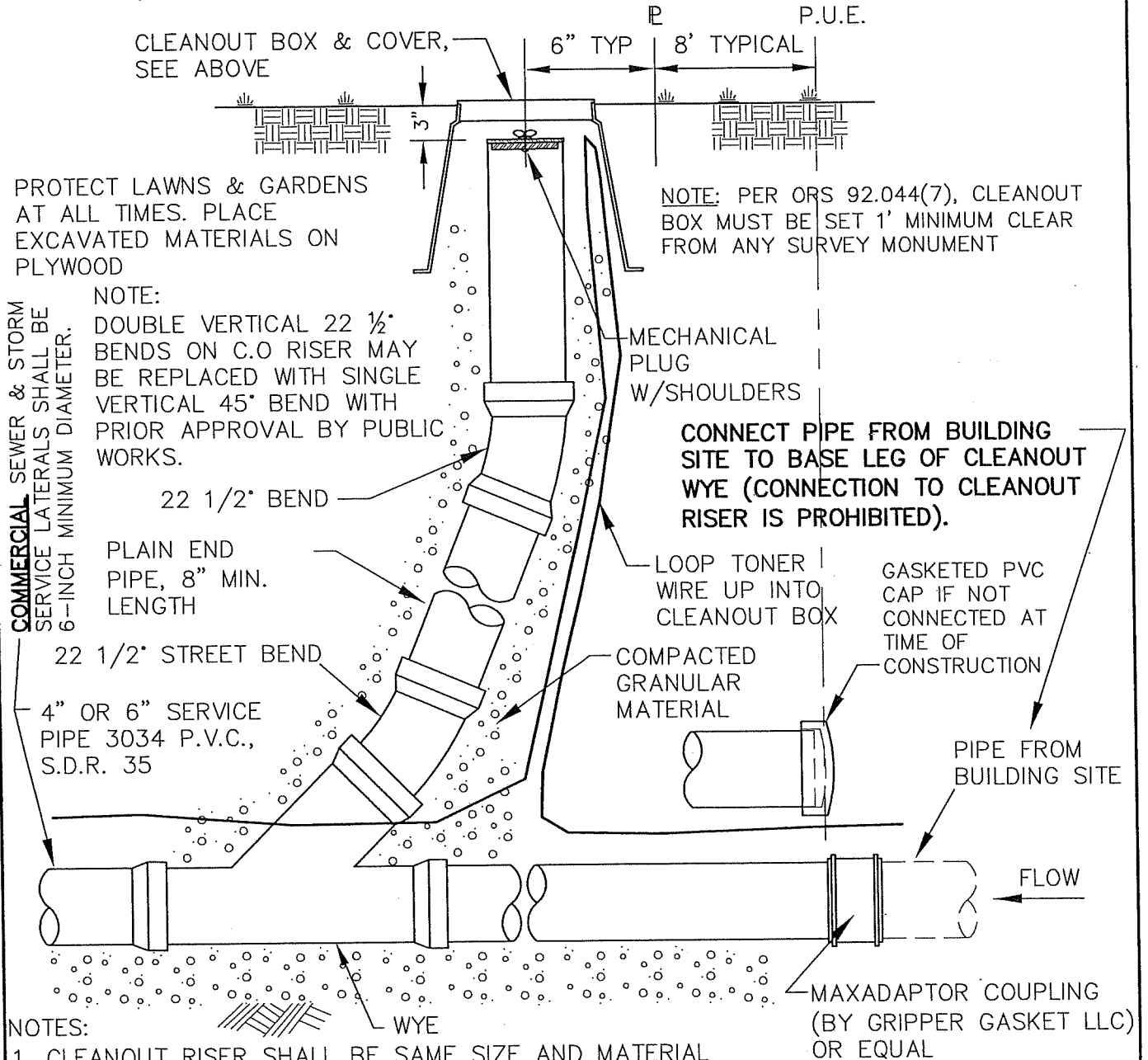

PROTECT LAWNS & GARDENS AT ALL TIMES. PLACE EXCAVATED MATERIALS ON PLYWOOD

NOTE: PER ORS 92.044(7), CLEANOUT BOX MUST BE SET 1' MINIMUM CLEAR FROM ANY SURVEY MONUMENT

NOTE: DOUBLE VERTICAL 22 1/2° BENDS ON C.O RISER MAY BE REPLACED WITH SINGLE VERTICAL 45° BEND WITH PRIOR APPROVAL BY PUBLIC WORKS.

COMMERCIAL SEWER & STORM SERVICE LATERALS SHALL BE 6-INCH MINIMUM DIAMETER.

22 1/2° BEND

PLAIN END PIPE, 8" MIN. LENGTH

22 1/2° STREET BEND

4" OR 6" SERVICE PIPE 3034 P.V.C., S.D.R. 35

MECHANICAL PLUG W/SHOULDERS

CONNECT PIPE FROM BUILDING SITE TO BASE LEG OF CLEANOUT WYE (CONNECTION TO CLEANOUT RISER IS PROHIBITED).

LOOP TONER WIRE UP INTO CLEANOUT BOX

GASKETED PVC CAP IF NOT CONNECTED AT TIME OF CONSTRUCTION

COMPACTED GRANULAR MATERIAL

PIPE FROM BUILDING SITE

FLOW

MAXADAPTOR COUPLING (BY GRIPPER GASKET LLC) OR EQUAL

NOTES:

- CLEANOUT RISER SHALL BE SAME SIZE AND MATERIAL AS LATERAL PIPE.
- PROVIDE CONCRETE PAD FOR CLEANOUTS LOCATED IN UNPAVED DRIVEWAYS OR TRAFFIC AREAS (6" THICK PAD TO BE 6" LARGER THAN CLEANOUT BOX FRAME).
- CLEANOUT PIPE SHALL BE LEFT A MINIMUM OF 18" ABOVE EXISTING GRADE UNTIL ALL CURBING IS INSTALLED AND ALL PRIVATE UTILITY TRENCHES ARE BACKFILLED. CLEANOUTS SHALL THEN BE SET NO MORE THAN 6" BELOW FINISH GRADE, AND CLEANOUT BOXES SET FLUSH WITH FINISH GRADE.

LAST REVISION DATE:

JULY 2022

COPYRIGHT 1995 WESTECH ENGINEERING, INC.

STANDARD SERVICE LATERAL CLEANOUT (SEWER & STORM)

(NTS)

DETAIL NO.

AUMSVILLE, OR

416

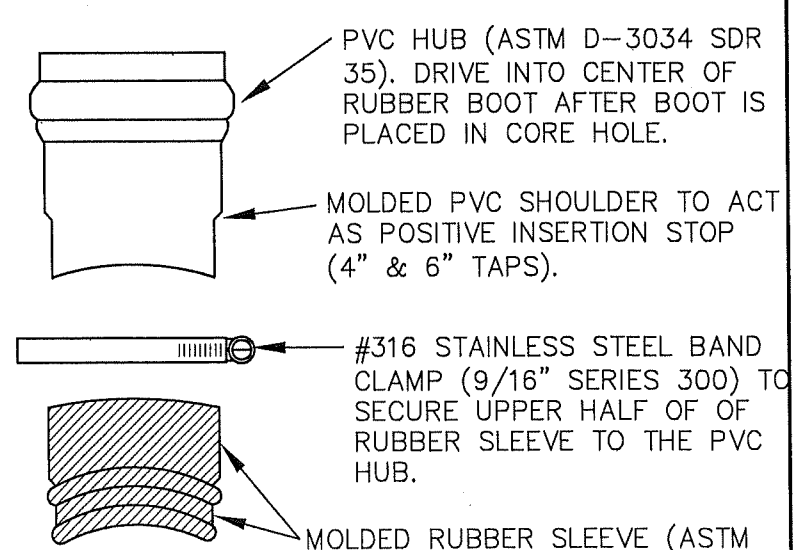
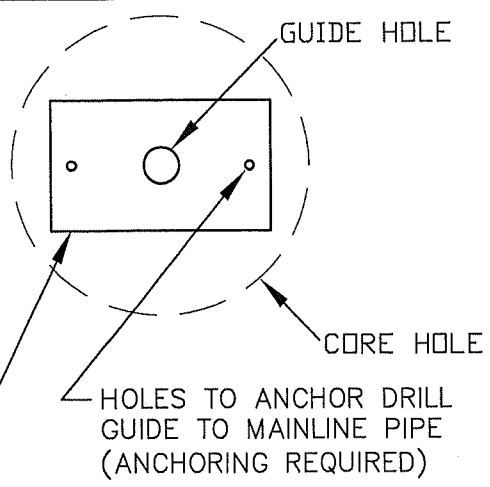

INSERTA-DRILL GUIDE (PROVIDED BY FITTING MANUFACTURER), SIZED TO FIT ENTIRELY WITHIN CORE HOLE DIAMETER (REQUIRED FOR ALL TAPS)

PVC HUB TO BE SHAPED TO MATCH PIPE I.D. AND SHALL NOT PROTRUDE BEYOND INSIDE DIAMETER OF RUBBER BOOT.

25-30° TYP. FOR SHALLOWER LATERALS (SEE DETAIL 4150)

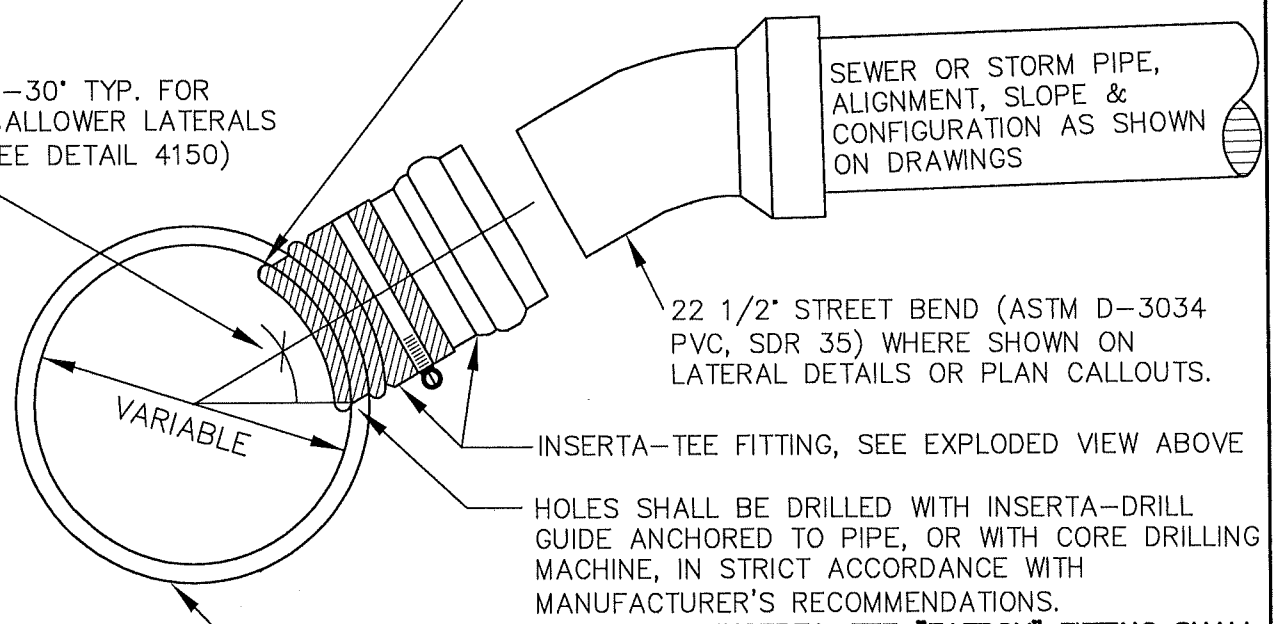

NOTES:

1. EXISTING SANITARY SEWERS - INSERTA-TEES ALLOWED ON EXISTING PVC OR DUCTILE IRON SEWER MAINS. USE ON OTHER PIPE TYPES IS SUBJECT TO CITY APPROVAL AND ACCEPTABLE PIPE CONDITION.
2. EXISTING STORM DRAINS - INSERTA-TEES ALLOWED ON ALL PIPE TYPES, SUBJECT TO CITY APPROVAL AND ACCEPTABLE PIPE CONDITION.
3. NEW MAINLINES - MANUFACTURED FITTINGS (PER DETAIL 415) SHALL BE USED FOR CONNECTION ON ALL NEW SEWER AND STORM MAINLINES.
4. THE TAP SHALL NOT BE MADE EXCEPT IN THE PRESENCE OF A CITY INSPECTOR; NOR SHALL ANY CONNECTION BE MADE WITHOUT PRIOR CITY APPROVAL.
5. CENTERLINE OF TAP SHALL BE ABOVE SPRINGLINE.

INSERTA-TEE "FATBOY" FITTING SHALL BE USED FOR ALL 4" & 6" TAPS ON EXTG PIPE (TV & 95% MANDREL TESTING OF EXISTING MAINLINES AFTER TAP MAY BE REQUIRED AT DISCRETION OF PUBLIC WORKS DIRECTOR).

LAST REVISION DATE: FEB 2021	JO # STANDARD
INSERTA-TEE CONNECTION TO EXISTING SEWER OR STORM DRAIN (NTS)	
AUMSVILLE, OR	DETAIL NO. 419

MANHOLE VACUUM TEST REPORT

Project Location: (City)				Project Name:			
Inspector: (Print)				Date: (Separate Report Required for Each Test Session)			
Testing Company: (Name & Phone #)							
Manhole No.	Manhole Diameter (inch)	Manhole Depth (ft)	Surface Restoration Complete?	Time Required ³ (sec)	Time to Drop from 10" Hg to 9" Hg (sec)	Results	Comments
			Yes / No			Pass / Fail	
			Yes / No			Pass / Fail	
			Yes / No			Pass / Fail	
			Yes / No			Pass / Fail	
			Yes / No			Pass / Fail	
			Yes / No			Pass / Fail	
			Yes / No			Pass / Fail	
			Yes / No			Pass / Fail	

1. All adjacent surface restoration shall be completed prior to conducting manhole acceptance tests, including finish paving and final adjustments to grade. Any test conducted prior to completion of surface restoration shall be considered informal, and will not count for acceptance.
2. The vacuum test head seal shall be inflated in accordance with the manufacturer's recommendations, but in all cases the grade rings and casting shall be included in the test. A vacuum of 10-inches of mercury shall be drawn and the vacuum pump shut off. With the valves closed, the time shall be measured for the vacuum to drop to 9-inches.
3. The manhole shall pass if the time for the vacuum reading to drop to 9-inches meets or exceeds the values indicated on the following table. Times for deeper depths as required by the City Engineer. Note: Visible groundwater infiltration or leakage constitutes a failed test.

REQUIRED MANHOLE VACUUM TEST TIMES			
Manhole Depth (feet)	Required Time (sec)		
	48-inch diameter	60-inch diameter	72-inch diameter
8	20	26	33
10	25	33	41
12	30	39	49
14	35	46	57
18	40	52	65
20	45	59	73
22	50	65	81

SANITARY SEWER AIR TEST REPORT

Project Location:	Project Name:
Inspector: (Print)	Date: (Separate Report Required for Each Test Session)
TV Inspection Required? Yes / No	Mandrel Testing Completed?
	Date Completed or Scheduled:
Verify that all sewer laterals and associated cleanouts installed and cleanout risers are visible at or above finish grade? Yes / No	Verify that all franchise utilities which cross sewer laterals have been installed and trenches backfilled? Yes / No

Station (& Manhole #)		Main/ Lateral	Size & Material	Total Length (ft)	C ¹	K ¹	Test Time (Seconds) for Pressure Drop Shown (psi)			Comments
							Required ²	4.0 - 3.5	3.5 - 2.5	
From	To									
		Main								Pass / Fail
		Laterals								
		Totals								
		Main								Pass / Fail
		Laterals								
		Totals								
		Main								Pass / Fail
		Laterals								
		Totals								
		Main								Pass / Fail
		Laterals								
		Totals								

¹ For C and K values, see table and formulas on reverse side.
² For total C ≤ 1.0, test time (seconds) required = 2 times K
For total C > 1.0, test time (seconds) required = 2 times (K/C)

TEST PROCEDURE

1. Add air slowly to the portion of the pipe installation under test until the internal air pressure is raised to 4.0 psig (or higher pressure as required to address groundwater). *Increase the test pressure by 0.433 psi for each foot of average ground water depth over the exterior crown of the pipe under test, with the maximum test pressure not to exceed 9.0 psi.*
2. Add air slowly until the internal air pressure is raised to 4.0 psig (or higher pressure as required due to groundwater).
3. After required test pressure is reached, allow 2-minutes minimum for air temperature to stabilize, adding only the amount of air required to maintain pressure.
4. After the temperature stabilization period, disconnect the air supply.
5. Record the time required for the internal air pressure to drop from 3.5 psi (or higher as required due to groundwater backpressure) to 2.5 psi (or higher as required due to groundwater backpressure). If this time exceeds the required time (or if there is less than 1.0 psi pressure drop), the test is successful.

ACCEPTANCE: The tested sewer section shall be considered acceptable if the pressure drop during the test time is less than 1.0 psi from the starting pressure.

SEWER AIR TEST C AND K VALUES

Pipe Size (inch)	C-Value ¹ per foot length	K-Value ² per foot length
4	0.00155	0.176
6	0.00233	0.396
8	0.00311	0.704
10	0.00388	1.100
12	0.00466	1.584
15	0.00582	2.475
18	0.00699	3.564
21	0.00815	4.851

¹ C = 0.0003882dL

Where d = diameter (inches)

² K = 0.011d²L

L = Length (ft)

Example:

Air Test a system consisting of two mainline segments as follows:

Segment 1: 395 feet of 8-inch mainline, 100 feet of 4-inch laterals, and 35 feet of 6 inch laterals.

Segment 2: 200 feet of 8-inch mainline, 30 feet of 4-inch laterals, and 20 feet of 6 inch laterals.

Station (& Manhole #)		Main/Lateral	Size & Material	Total Length (ft)	C ¹	K ¹	Test Time (Seconds) for Pressure Drop Shown (psi)			Comments	
From	To						Required ²	4.0 - 3.5	3.5 - 2.5		
0+00 MH A1	3+95 MH A2	Main	8" PVC	395	1.227	278.1	310/1.46= 212			Pass / Fail	
		Laterals	4" PVC 6" PVC	100 35	0.155 0.082	17.6 13.86					212*2= 414 sec
		Totals			1.464	309.54					
3+95 MH A2	5+95 MH A3	Main	8" PVC	200	0.621	140.8	2*154= 308 sec			Pass / Fail	
		Laterals	4" PVC 6" PVC	20 30	0.047 0.047	5.28 7.92					
		Totals			0.714	154.0					

Note: For total C \leq 1.0, test time (seconds) required = 2 times K

For total C > 1.0, test time (seconds) required = 2 times (K/C)

The tested sewer section shall be considered acceptable when tested as described herein if the section under test does not loose air at a rate greater than 0.0015 cfm per square foot of internal sewer surface.

SANITARY SEWER MANDREL TEST REPORT

Project Location: (City)	Project Name:
Inspector: (Print)	Date: (Separate Report Required for Each Test Session)
Mandrel Diameters Verified? Yes / No	

Station (& Manhole #)		Size & Material	Length (ft)	Results	Backfill Compaction Completed?	Date Sewer Flushed & Cleaned	Comments
From	To						
				Pass / Fail	Yes / No		
				Pass / Fail	Yes / No		
				Pass / Fail	Yes / No		
				Pass / Fail	Yes / No		
				Pass / Fail	Yes / No		
				Pass / Fail	Yes / No		
				Pass / Fail	Yes / No		
				Pass / Fail	Yes / No		
				Pass / Fail	Yes / No		
				Pass / Fail	Yes / No		
				Pass / Fail	Yes / No		
				Pass / Fail	Yes / No		
				Pass / Fail	Yes / No		
				Pass / Fail	Yes / No		
				Pass / Fail	Yes / No		

1. Mandrel testing shall be conducted on a manhole to manhole (or cleanout) basis and shall be done after the line has been completely flushed out with water.
2. Mandrel testing shall be conducted after trench backfill and compaction has been completed.
3. The mandrel diameter shall be 95% of the pipe initial inside diameter. The inspector shall verify the diameter of each mandrel used during each test session.

SEWER PIPELINE TV INSPECTION REPORT

Date:	Client: City:	Basin No.				
Technician:	Inspector:	Weather:	Cleaned By:	Report No.	Tape No.	
From M.H. #: Street:	Pipe Dia. (in)	Joint Length (ft)	Section Length (ft)	Joint Type:	Pipe Material	To M.H. #: Street:

PIPELINE DATA;				
Cleanliness: _____	Footage	Problem Code	Comments	I/I (gpm)
Alignment: _____				
Grade: _____				
Age: _____				
%Est. Leaking Joints: _____				
Other: _____				

PROBLEM CODE LEGEND:				
BP = Broken Pipe				
CC = Circumferential Crack				
LC = Longitudinal Crack				
G = Break in Grade				
L = Leak				
PJ = Pulled Joint				
PT = Protruding Tap				
ST = Service Tap				
SL = Service Left				
SR = Service Right				
RT = Roots				
U = Unpassable				
PIPE MATERIAL LEGEND:				
AC = Asbestos Cement				
CIP = Cast Iron Pipe				
C(M) = Conc., Mortor Joint				
C(R) = Conc., Rubr. Gasket Jnt				
DI = Ductile Iron Pipe				
PVC = Polyvinylchloride Pipe				
TC = Terra Cotta				
VC = Vitrifed Clay				
TURNAROUND:				
Requested (Date/time): _____				
Authorized (Date/time): _____				

FINISH GRADE

VALVE BOX TO BE CONCRETE ENCASED IF NOT IN PAVED AREA. 3300 PSI @ 28 DAYS, MAX 5" SLUMP, 4.5% AIR (±1.5%). (ROUND OR SQUARE PAD)

CAST IRON VALVE BOX & LID 'VANCOUVER' STYLE

6" PVC SEWER PIPE, ASTM D3034, SDR 35, LENGTH AS REQUIRED

VC212 VALVE BOX BASE BY 3DC, OR EQUAL

RESILIENT WEDGE GATE VALVE (GV) EPOXY COATED PER AWWA C-550

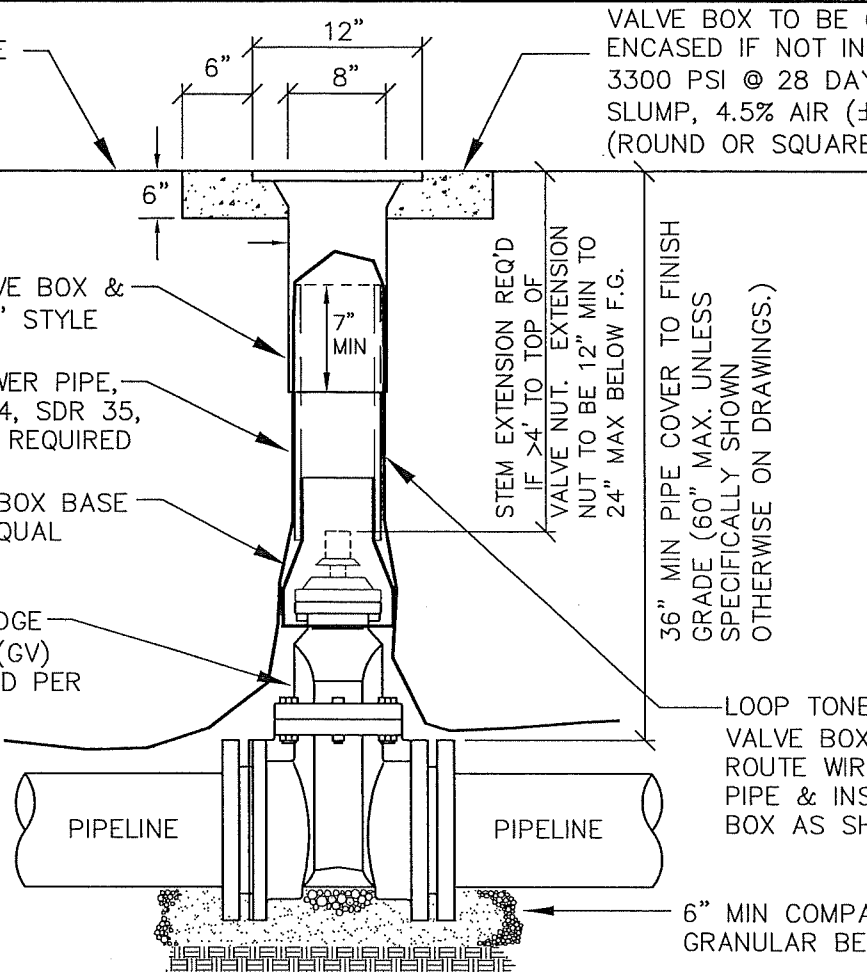

STEM EXTENSION REQ'D IF >4' TO TOP OF VALVE NUT. EXTENSION NUT TO BE 12" MIN TO 24" MAX BELOW F.G.

36" MIN PIPE COVER TO FINISH GRADE (60" MAX. UNLESS SPECIFICALLY SHOWN OTHERWISE ON DRAWINGS.)

LOOP TONER WIRE UP INTO VALVE BOX (TYP ALL). ROUTE WIRE OUTSIDE RISER PIPE & INSIDE OF VALVE BOX AS SHOWN.

6" MIN COMPACTED GRANULAR BEDDING

STABLE SUBGRADE

GRIND NOTCH IN FRAME, 1/8" WIDE x 1/8" DEEP, INDICATING DIRECTION OF FLOW THROUGH VALVE (BOTH SIDES)

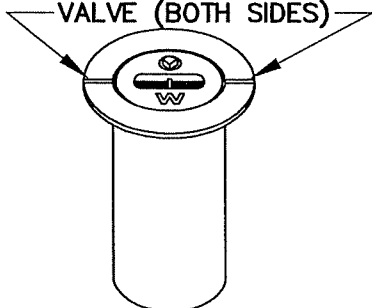

VANCOUVER '910' STYLE
18" TALL VALVE BOX

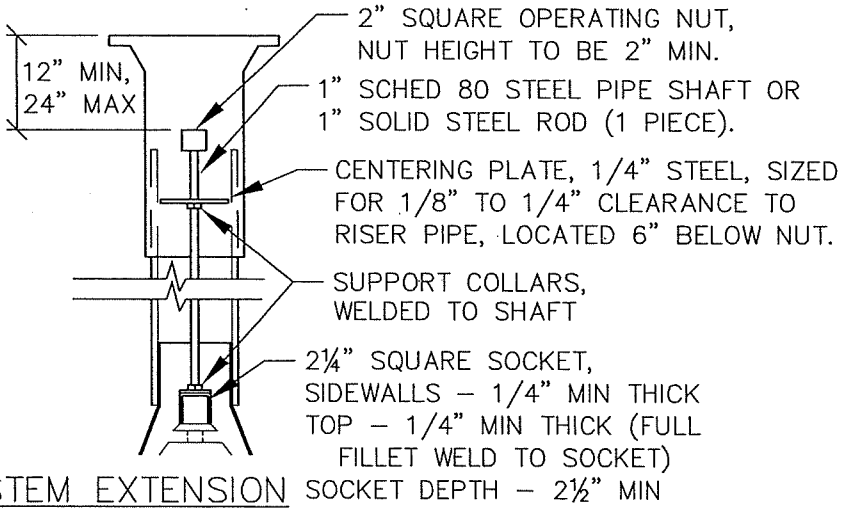

STEM EXTENSION SOCKET DEPTH - 2 1/2" MIN

NOTES:

1. GV SHALL CONFORM TO AWWA C-509.
2. VALVE BOXES SHALL BE PLUMB AND CENTERED DIRECTLY OVER THE VALVE NUT, INSTALLED ON VALVE BOX BASE AS SHOWN.
3. VALVE BOX TOP SHALL BE ADJUSTED TO FINISHED GRADE.
4. PVC SHALL BE ONE CONTINUOUS PIECE, NO BELLS OR COUPLERS.
5. VALVE BOX LIDS ON PRESSURE SEWERS TO READ "S" OR "SEWER".
6. COMPLETELY CLEAN OUT ALL VALVE BOX COVER PICKHOLES PRIOR TO REQUESTING FINAL INSPECTION.

LAST REVISION DATE: DEC 2022	JO # STANDARD
GATE VALVE AND VALVE BOX DETAIL	
(NTS)	
AUMSVILLE, OR	DETAIL NO. 501

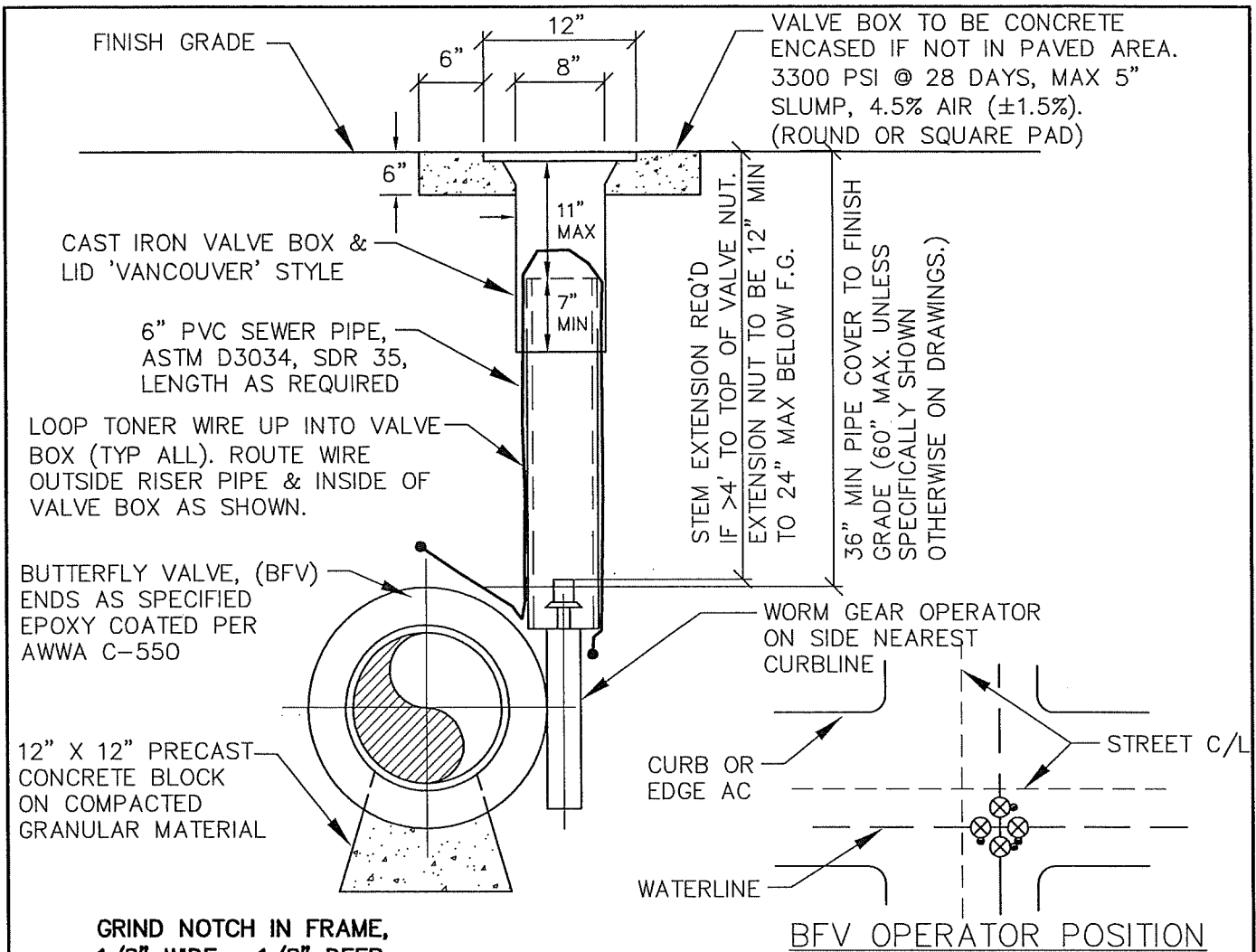

GRIND NOTCH IN FRAME, 1/8" WIDE x 1/8" DEEP, INDICATING DIRECTION OF FLOW THROUGH VALVE (BOTH SIDES)

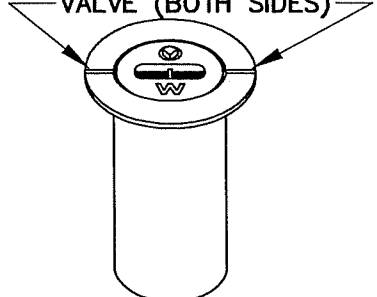

VANCOUVER '910' STYLE
18" TALL VALVE BOX

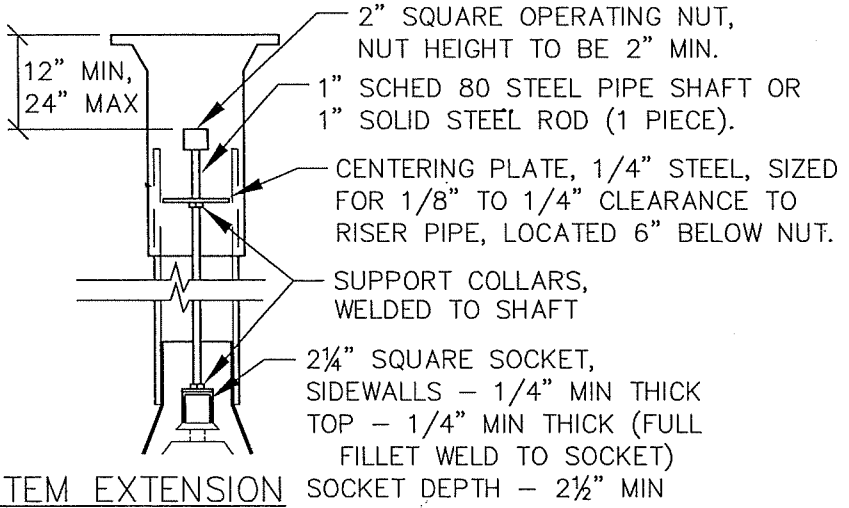

STEM EXTENSION

NOTES:

1. BFV SHALL BE SHORT BODY TYPE B PER AWWA C-504.
2. VALVE BOXES SHALL BE PLUMB AND CENTERED DIRECTLY OVER THE VALVE NUT.
3. VALVE BOX TOP SHALL BE ADJUSTED TO FINISHED GRADE.
4. PVC SHALL BE ONE CONTINUOUS PIECE, NO BELLS OR COUPLERS.
5. BFV ACTUATOR TO BE LOCATED ON THE CURBLINE SIDE OF WATERLINE AS SHOWN. INSTALL DI SPOOLS OR FLEX ADAPTER IF REQUIRED FOR ACTUATOR CLEARANCE.
6. COMPLETELY CLEAN OUT ALL VALVE BOX COVER PICKHOLES PRIOR TO REQUESTING FINAL INSPECTION.

LAST REVISION DATE: DEC 2022	JO # STANDARD
BUTTERFLY VALVE AND VALVE BOX DETAILS	
(NTS)	
AUMSVILLE, OR	DETAIL NO. 502

NOTE: HYDRANT COLOR TO BE FACTORY RED

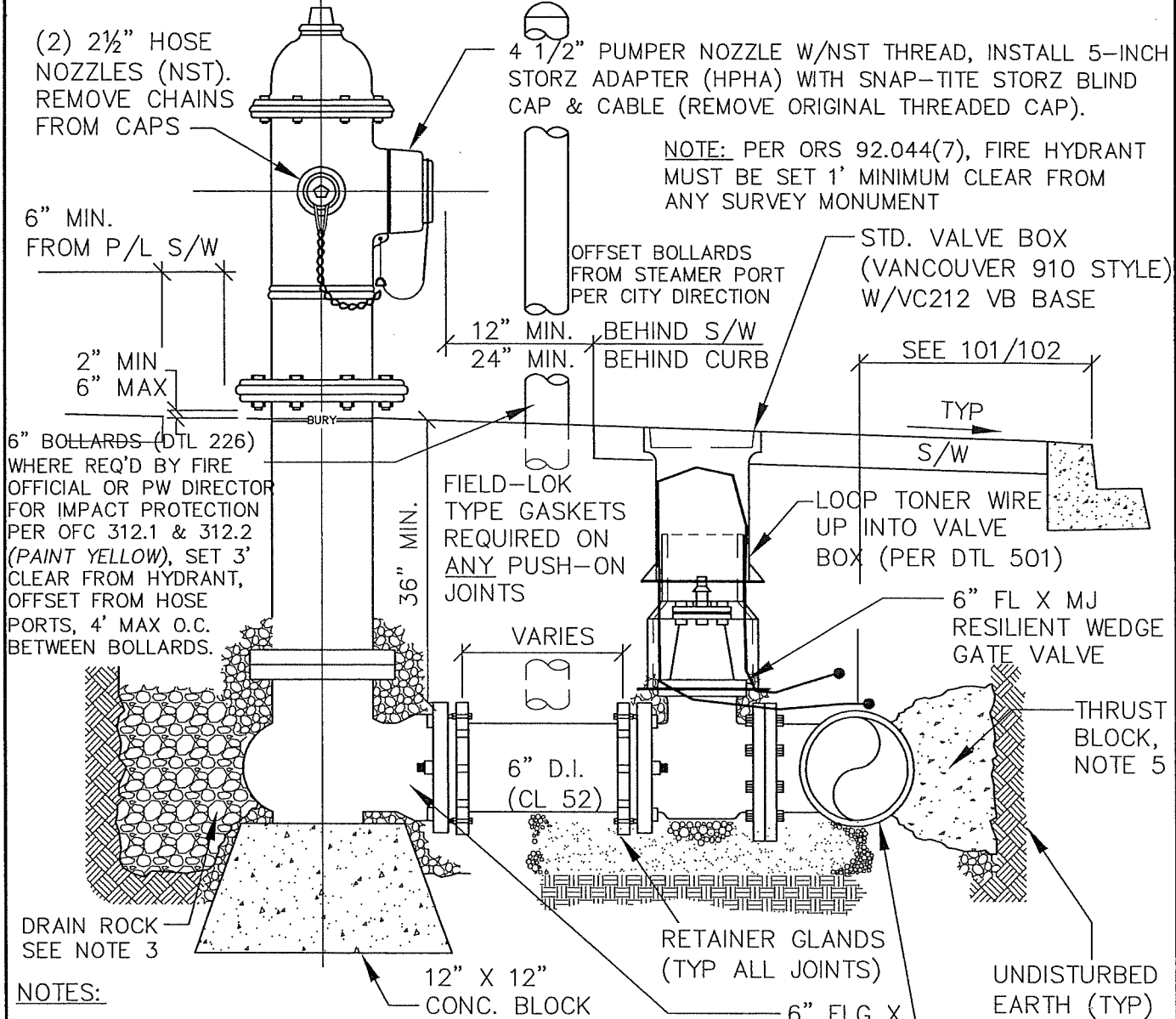

NOTES:

1. HYDRANTS TO BE MUELLER SUPER CENTURION 250, MODEL A423, WITH FULL SIZE (5 1/4") FOOT VALVE.
2. **ALL FITTINGS IN CONTACT WITH CONCRETE SHALL BE WRAPPED IN PLASTIC.** HYDRANT DRAIN HOLES TO REMAIN OPEN TO DRAIN ROCK AND OPERATIONAL.
3. 1-1/2" TO 3/4" CLEAN DRAIN ROCK SHALL BE PLACED TO A MIN. OF 6" ABOVE DRAIN OUTLET.
4. WHERE PLANTER STRIP EXISTS, HYDRANT SHALL BE PLACED SO FRONT PORT IS A MIN. OF 24" BEHIND FACE OF CURB.
5. THRUST BLOCK AT STANDARD 6" FIRE HYDRANT TEE SHALL HAVE MIN. 3.7 SQ. FT. BEARING AREA.
6. ALL HYDRANTS SHALL BE SET PLUMB.
7. FOR HYDRANT LEADS LONGER THAN 30', AN ADDITIONAL GATE VALVE SHALL BE PROVIDED WITHIN 3 FT. OF THE HYDRANT.
8. RESTRAIN ALL JOINTS ON ALL HYDRANT LEADS. RETAINER GLANDS SHALL TO BE USED IN LEIU OF THRUST BLOCK BEHIND HYDRANT.
9. PAINT CURB (TOP & FACE) YELLOW 10 FEET EACH WAY FROM HYDRANT & INSTALL REFLECTIVE BLUE TRAFFIC MARKER @ STREET CENTERLINE.

LAST REVISION DATE: FEB 2023	COPYRIGHT 1996 WESTECH ENGINEERING, INC.
STANDARD FIRE HYDRANT ASSEMBLY	
(NTS)	
AUMSVILLE, OR	DETAIL NO. 503

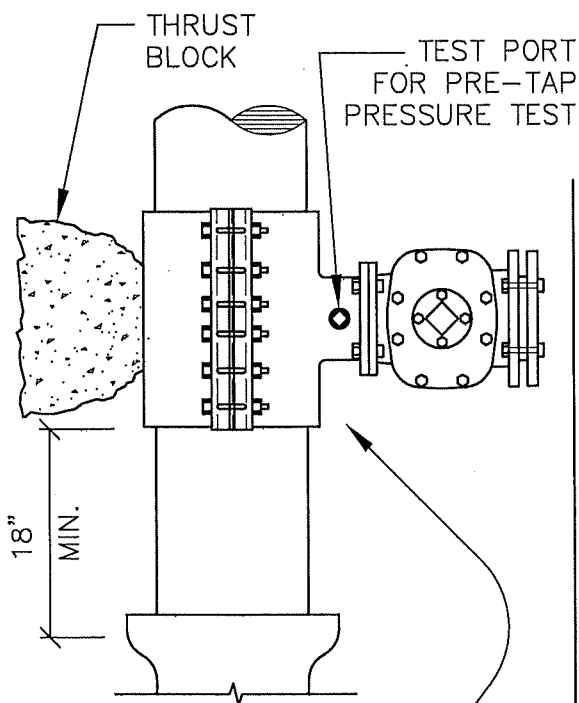

ROMAC SST/SSTIII, MUELLER H304,
JCM MODEL 432 OR APPROVED EQUAL
(STAINLESS STEEL SLEEVE AND STAINLESS
STEEL FLANGE)

TOP VIEW

STD. VALVE BOX
(VANCOUVER '910'
STYLE) W/VC212 VB
BASE & PVC RISER

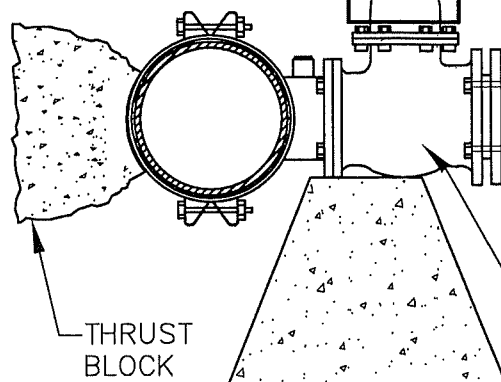

12" X 12"
CONCRETE BLOCK

RESILIENT WEDGE GATE VALVE
(FL x MJ UNLESS OTHERWISE
NOTED ON PLANS)

SIDE VIEW

NOTES:

1. WATER MAIN SHALL BE CLEANED & SPRAYED WITH CHLORINE SOLUTION IN TAP AREA BEFORE ATTACHING SLEEVE.
2. TAPPING SLEEVE SHALL BE ALL STAINLESS STEEL WITH FULL PERIMETER GASKET.
3. TAPPING VALVE SHALL BE EPOXY COATED PER AWWA C-550.
4. PRE-TAP PRESSURE TEST. SLEEVE AND VALVE SHALL BE PRESSURE TESTED BEFORE MAKING TAP. PRESSURE TEST AND TAP SHALL BE MADE IN THE PRESENCE OF AN AUTHORIZED WATER SYSTEM REPRESENTATIVE.
5. APPROVED TAPPING MACHINE SHALL BE USED TO MAKE TAP.
6. 3/4" GRANULAR BACKFILL SHALL BE PLACED AND COMPACTED TO 92% OF MAXIMUM DENSITY AS DETERMINED BY AASHTO T-180.
7. THRUST BLOCKING PER DETAIL 510.
8. TAP SHALL BE MADE NO CLOSER THAN 18" FROM THE NEAREST JOINT.
- 9. SLEEVE AND VALVE SHALL BE WRAPPED WITH 8 MIL PLASTIC PRIOR TO CONCRETE PLACEMENT.**
10. CONCRETE BLOCK(S) SHALL COMPLETELY SUPPORT TAPPING TEE AND VALVE.
11. CONTRACTOR SHALL COORDINATE ALL TAPS WITH CITY AND PERFORM ALL TAPS WITH PUBLIC WORKS STAFF PRESENT.
12. ALL TAPPING EQUIPMENT (AND ANY TOOL COMING IN CONTACT WITH THE PIPE THROUGH THE TAPPING SLEEVE) SHALL BE CHLORINE DISINFECTED WITH A 300 MG/L CHLORINE SOLUTION.

LAST REVISION DATE: FEB 2021	COPYRIGHT 1996 WESTECH ENGINEERING, INC.
TAPPING TEE AND VALVE	
(NTS)	
AUMSVILLE, OR	DETAIL NO. 505

**BLOW-OFF
SIZES REQUIRED
(ASSUMES 40 PSI RESIDUAL PRESS.)**

MAIN SIZE	BLOW-OFF SIZE
6" - 8"	2"
10" - 12"	4"
>12"	BY ENGR.

FOR BLOWOFFS LARGER THAN 2", USE KUPFERLE MAINGUARD #7600 BLOW-OFF, OR APPR'D EQUAL. PROVIDE SEPARATE EXTENSION RISER ADAPTER W/HORIZONTAL 4½" HOSE THREAD OUTLET.

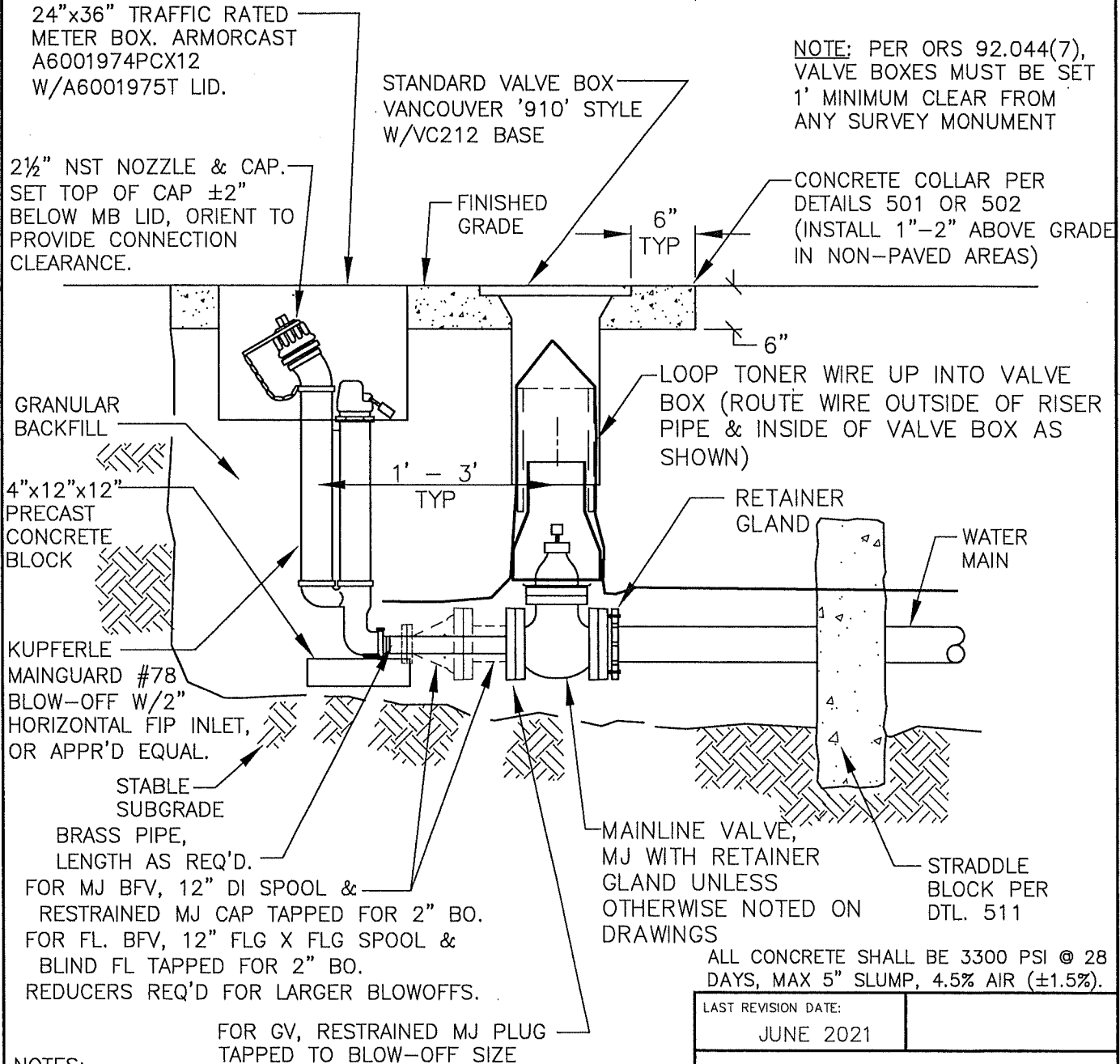

NOTES:

1. BACKFILL WITH GRANULAR BACKFILL.
2. REQUIRED ON ALL LINES WHICH MAY BE EXTENDED IN FUTURE OR AS DIRECTED BY PUBLIC WORKS DIRECTOR.
3. ALL CONCRETE TO BE 3300 PSI @ 28 DAYS.
4. DUCTILE IRON PIPE AND FITTINGS REQUIRED FOR 4" & LARGER BLOWOFFS.

ALL CONCRETE SHALL BE 3300 PSI @ 28 DAYS, MAX 5" SLUMP, 4.5% AIR (±1.5%).

LAST REVISION DATE: JUNE 2021	
MAINLINE BLOWOFF ASSEMBLY	
(NTS)	
AUMSVILLE, OR	DETAIL NO. 506

24"x36" TRAFFIC RATED
METER BOX. ARMORCAST
A6001974PCX12
W/A6001975T LID.

STANDARD VALVE BOX
VANCOUVER '910' STYLE
W/VC212 BASE

NOTE: PER ORS 92.044(7),
VALVE BOXES MUST BE SET
1' MINIMUM CLEAR FROM
ANY SURVEY MONUMENT

2 1/2" NST NOZZLE & CAP.
SET TOP OF CAP ±2"
BELOW MB LID, ORIENT TO
PROVIDE CONNECTION
CLEARANCE.

CONCRETE COLLAR PER
DETAILS 501 OR 502
(INSTALL 1"-2" ABOVE GRADE
IN NON-PAVED AREAS)

GRANULAR
BACKFILL

4"x12"x12"
PRECAST
CONCRETE
BLOCK

KUPFERLE
MAINGUARD #78
BLOW-OFF W/2"
HORIZONTAL FIP INLET,
OR APPR'D EQUAL.

STABLE
SUBGRADE

BRASS PIPE,
LENGTH AS REQ'D.

EPOXY COATED RESILIENT
WEDGE GATE VALVE (2" MIN)
WITH 2" SQUARE OPERATING
NUT

MJ CAP & RETAINER
GLAND (TAPPED TO
BLOWOFF SIZE)

FINISHED
GRADE

6"
TYP

6"

BRASS
NIPPLE

LOOP TONER WIRE UP INTO VALVE
BOX (ROUTE WIRE OUTSIDE OF RISER
PIPE & INSIDE OF VALVE BOX AS
SHOWN)

6" & 8"
WATER MAIN

STRADDLE
BLOCK PER
DTL 511

ALL CONCRETE SHALL BE 3300 PSI @ 28
DAYS, MAX 5" SLUMP, 4.5% AIR (±1.5%).

LAST REVISION DATE:

JUNE 2021

COPYRIGHT 1996
WESTECH ENGINEERING, INC.

STANDARD BLOWOFF
WITH PLUGGED END

(NTS)

DETAIL NO.

AUMSVILLE, OR

507

NOTES:

1. BACKFILL WITH GRANULAR BACKFILL.
2. ALLOWED ONLY ON PERMANENT DEAD END LINES IN CUL-DE-SACS WHICH CANNOT BE EXTENDED IN THE FUTURE.
3. ALL CONCRETE TO BE 3300 PSI @ 28 DAYS.
4. 2" BLOWOFF SIZE ASSUMES 40 PSI RESIDUAL PRESSURE.

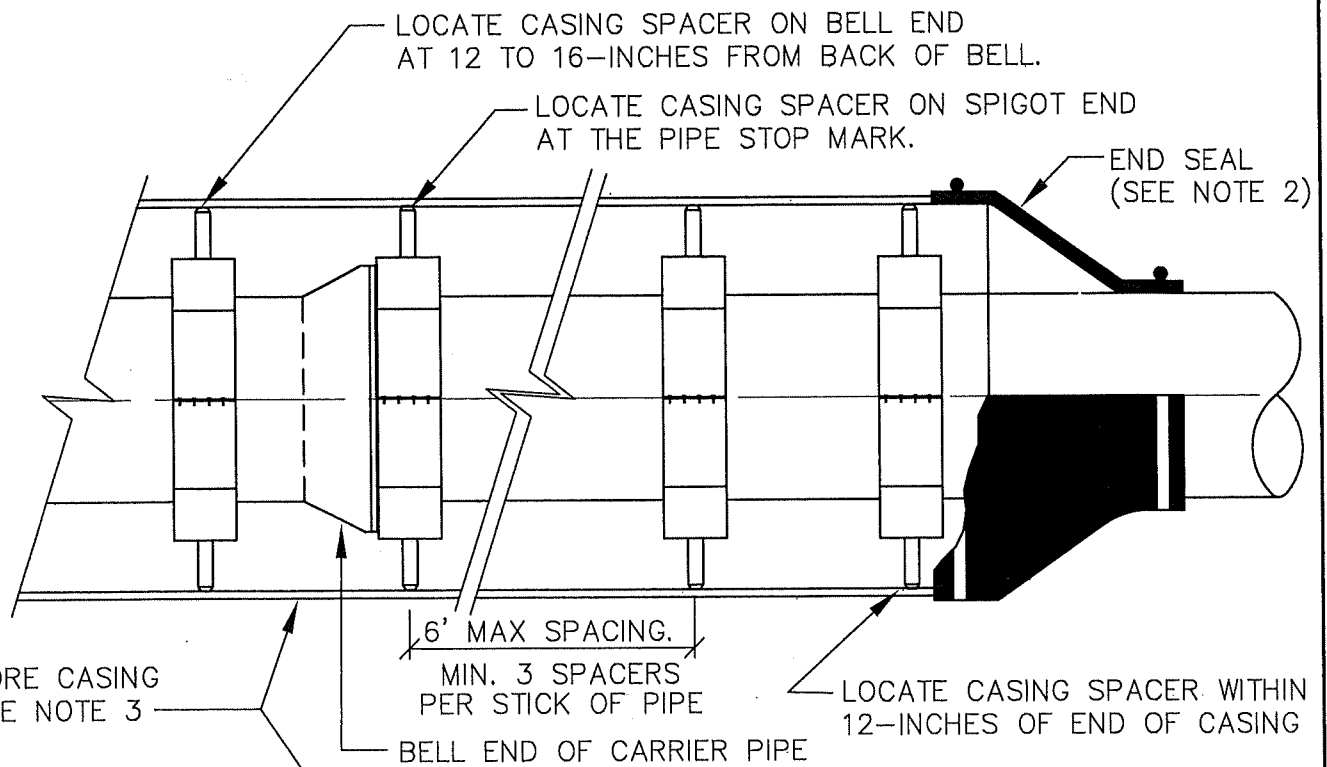

BORE CASING
SEE NOTE 3

CASING SPACER WITH
STAINLESS STEEL BAND
& STAINLESS STEEL
FASTENERS.

STAINLESS STEEL
RISER

UHMW POLYMER
PLASTIC RUNNER

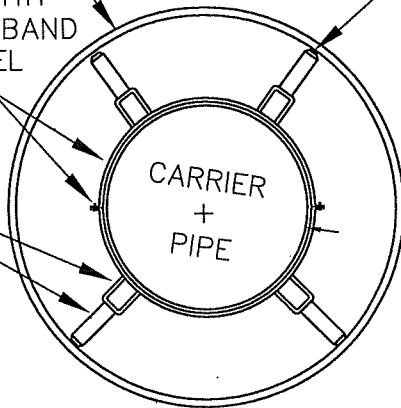

SEE NOTE 5 FOR RUNNER TO BORE
CLEARANCE REQUIREMENTS FOR GRAVITY
CARRIER PIPES.

CARRIER PIPE DIAMETER	MIN. DIA. CASING (*1, *2)	MIN CASING WALL THICKNESS (INCH)
6"	12"	0.25 (1/4)
8"	14"	0.25 (1/4)
10"	16"	0.312 (5/16)
12"	18"	0.375 (3/8)

*1: CASING SIZE LISTED IS FOR PRESSURE PIPE. LARGER DIA CASING REQ'D FOR GRAVITY PIPE.
*2: SEE PWDS 5.8.m FOR GRAVITY PIPE CASING SIZE REQUIREMENTS OR LARGER CASING SIZES.

NOTES:

- CASING SPACERS - APS MODEL SSI, CALPICO M-SS SERIES OR APPROVED EQUIV. 4"-18" CARRIER PIPE, USE 8" WIDE BAND. >18" CARRIER PIPE, USE 12" WIDE BAND.
- SEAL BOTH ENDS OF BORE CASING WITH END SEALS. WITHOUT SAND FILL, USE APS MODEL AZ OR APPROVED EQUIV. FASTEN TO CASING AND CARRIER PIPE WITH ST. STEEL BANDS. WITH SAND FILL, USE GROUT END CAPS (PLUG VENT TUBES AFTER SAND FILL)
- CASING SHALL BE WELDED SMOOTH STEEL PIPE CONFORMING TO ASTM A-53, GRADE B OR APPROVED EQUIVALENT ($F_y = 35,000$ psi).
- CARRIER PIPE DIAMETER & MATERIAL AS PER DWGS.
- FOR GRAVITY SEWER OR STORM CARRIER PIPES, THE CASING ANNULAR SPACE SHALL BE COMPLETELY FILLED WITH SAND TO PREVENT FLOATION OF CARRIER PIPE BY GROUNDWATER.
- CARRIER PIPE SHALL BE COMPLETELY FILLED WITH WATER PRIOR TO INSTALLING OR BLOWING SAND.
- INCREASE CASING DIA AS REQ'D TO ALLOW TRIMMING OF CASING SPACERS ON GRADE CRITICAL BORES

LAST REVISION DATE:
FEB 2021

COPYRIGHT 1996
WESTECH ENGINEERING, INC.

**BORE CASING, CARRIER
PIPE AND CASING SPACER
DETAIL**

(NTS)

AUMSVILLE, OR

DETAIL NO.

508

FITTING SIZE (Inches)	TEE, WYE, & ① HYDRANTS	90° BEND ② PLUGGED CROSS TEE PLUGGED-RUNS	45° BEND ③	22 1/2° BEND ③	11 1/4° BEND ③
2	*	*	*	*	*
4	1.7	2.4	1.3	*	*
6	3.7	5.3	2.9	1.5	*
8	6.7	9.5	5.1	2.7	1.3
10	10.5	14.8	8	4.1	2
12	15.1	21.3	11.6	5.9	2.9
16	26.8	37.9	20.5	10.4	5.2
18	33.9	47.9	25.9	12.8	6.7
LARGER	* *	* *	* *	* *	* *
BEARING AREA OF THRUST BLOCKS (sq. ft.)					

- ALL VALUES ARE BASED ON THE FOLLOWING ASSUMPTIONS:
AVG. PRESSURE = 100 PSI x 2 (safety factor); 1500 PSF SOIL BEARING CAPACITY;
NORMAL DISTRIBUTION SYSTEM DESIGN VELOCITY NOT TO EXCEED 5 FPS.
- ALL FITTINGS SHALL BE WRAPPED IN PLASTIC PRIOR TO PLACEMENT OF CONCRETE.**
- BEARING SURFACE OF THRUST BLOCKING SHALL BE AGAINST UNDISTURBED SOIL.
- TRUCK-MIXED CONCRETE MIX SHALL HAVE A MIN. 28 DAY STRENGTH OF 3300 PSI (5" MAX SLUMP). USE OF HAND-MIXED SACK-CRETE TYPE CONCRETE REQUIRES WRITTEN CITY APPROVAL PRIOR TO USE, AND SHALL BE 4000 PSI MIX, MIXED WITH MIN AMOUNT OF WATER NECESSARY FOR WORKABILITY (5" MAX SLUMP). USE OF DRY SACK-CRETE MIX (BAGS OR LOOSE MIX) IS PROHIBITED FOR PERMANENT THRUST RESTRAINT.
- ALL PIPE ZONES SHALL BE BACKFILLED WITH GRANULAR BACKFILL AND COMPACTED.
- THRUST BLOCKS FOR PLUGGED CROSS AND PLUGGED TEE SHALL HAVE #4 REBAR LIFTING LOOPS INSTALLED AS SHOWN.
- VERTICAL THRUST DETAILS-SEE DWG. 512.
- STRADDLE BLOCK DETAILS-SEE DWG. 511.
 - * BLOCK TO UNDISTURBED TRENCH WALLS
 - * * THRUST BLOCKS FOR PIPES LARGER THAN 18" WILL BE INDIVIDUALLY DESIGNED BY THE ENGINEER.

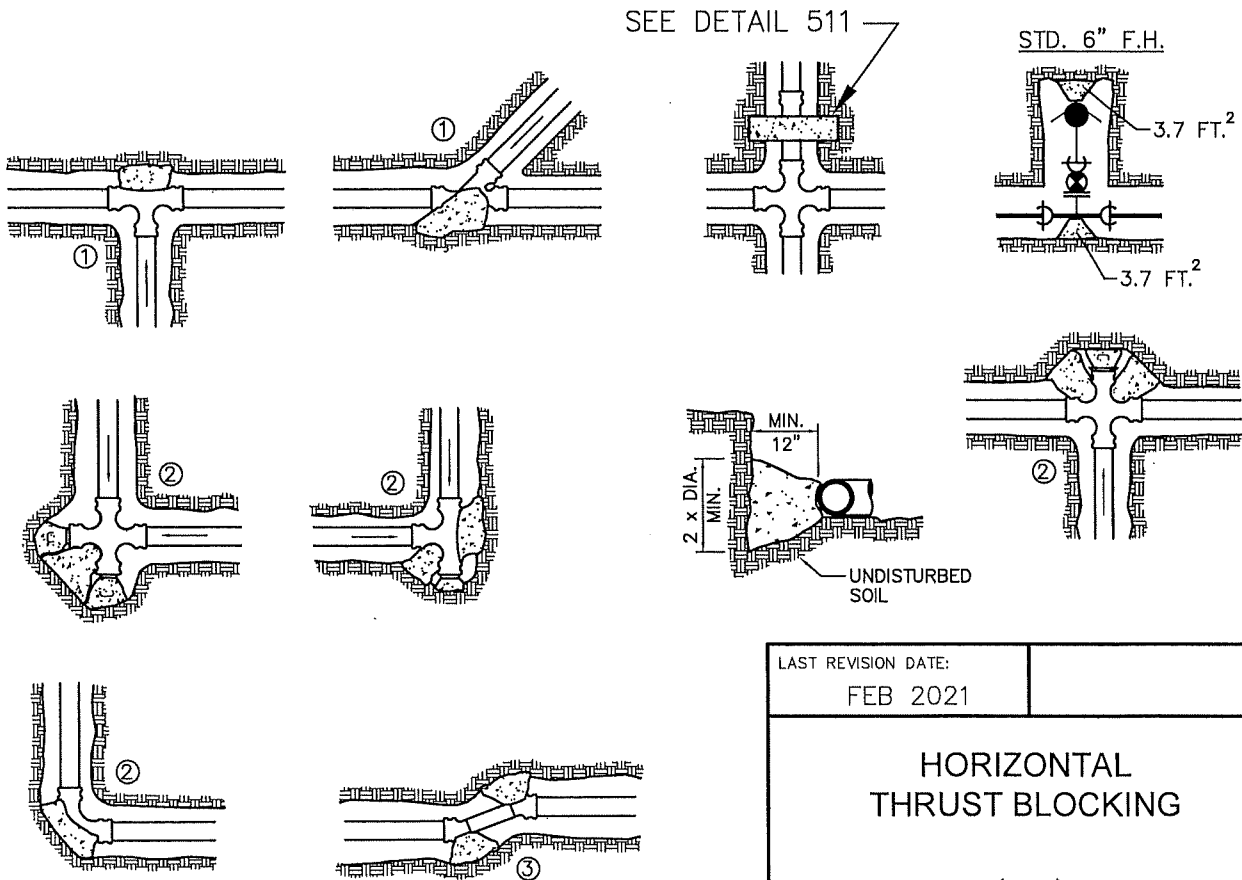

LAST REVISION DATE: FEB 2021	
HORIZONTAL THRUST BLOCKING	
(NTS)	
AUMSVILLE, OR	DETAIL NO. 510

MATERIALS

- ① CONCRETE STRADDLE BLOCK.
- ② - EITHER (2a) ONE SERRATED-LOCK STYLE SPLIT-RING RESTRAINT HARNESS (ROMAC 600 OR EQUAL), OR (2b) TWO RETAINER GLAND WEDGE-STYLE RESTRAINTS, SET OPPOSED (EBBA MEGA-LUG OR EQUAL).
- WEDGE STYLE RESTRAINTS SHALL BE WRAPPED WITH PLASTIC PRIOR TO CONCRETE PLACEMENT.
- ③ ≤12" PIPE, #4 REBAR @12" O.C. E.W., (3a) INSTALL REBAR EACH SIDE OF RESTRAINT FITTING INSIDE CONCRETE AS SHOWN. (3b) INSTALL 3 MATS OF REBAR FOR PIPE LARGER THAN 12" DIAMETER.
- ④ RETAINER GLAND, ON ADJACENT FITTING.
- ⑤ MJ FITTING, BEND, VALVE OR BLOWOFF.

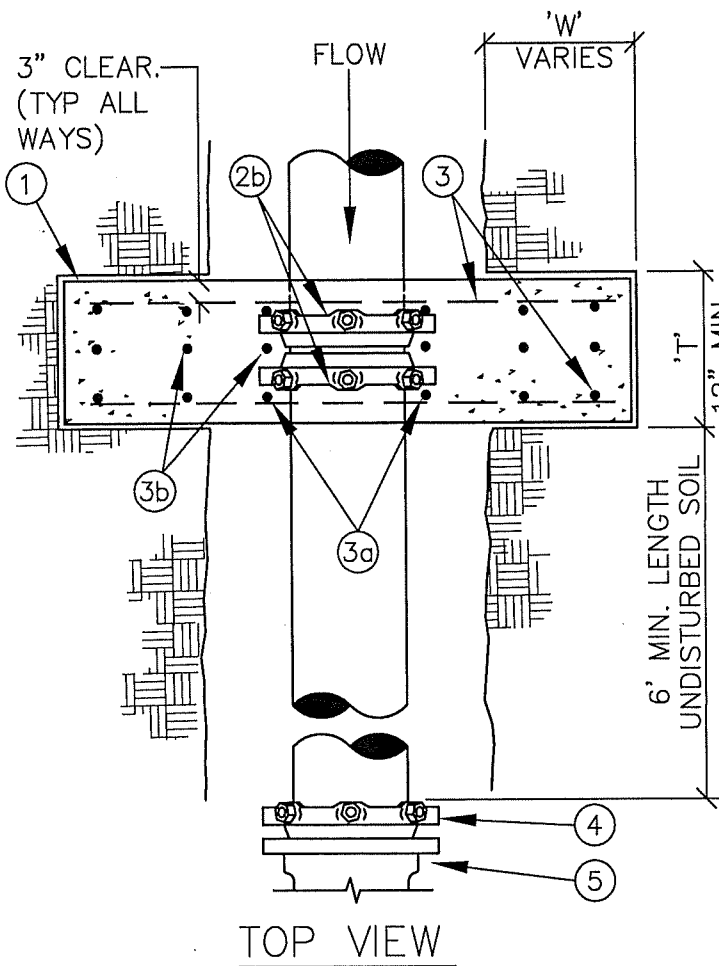

PIPE SIZE	'W'	'D'	'T'
6"	12"	8"	12"
8"	16"	10"	12"
10"	20"	12"	12"
12"	24"	18"	18"
14"&16"	28"	24"	18"
18"	32"	30"	18"
>12"	SIZE TO BE VERIFIED BY DESIGN ENG (NOTE 1).		

NOTES:

1. STRADDLE BLOCKS FOR >12" PIPE SHALL BE VERIFIED INDIVIDUALLY FOR APPLICATION BY THE DESIGN ENGINEER AND SHALL BE BASED ON THE FOLLOWING:
 - a.) 200 PSI WATER TEST PRESSURE.
 - b.) SOIL BEARING CAPACITY, REBAR SIZE & SPACING VERIFIED BY THE ENGINEER.
2. BEARING AREA OF BLOCK SHALL BE AGAINST UNDISTURBED SOIL.
3. STRADDLE BLOCK SHALL HAVE A MINIMUM OF 18" COVER.
4. CONCRETE SHALL HAVE A MIN. 28 DAY STRENGTH OF 3300 PSI.

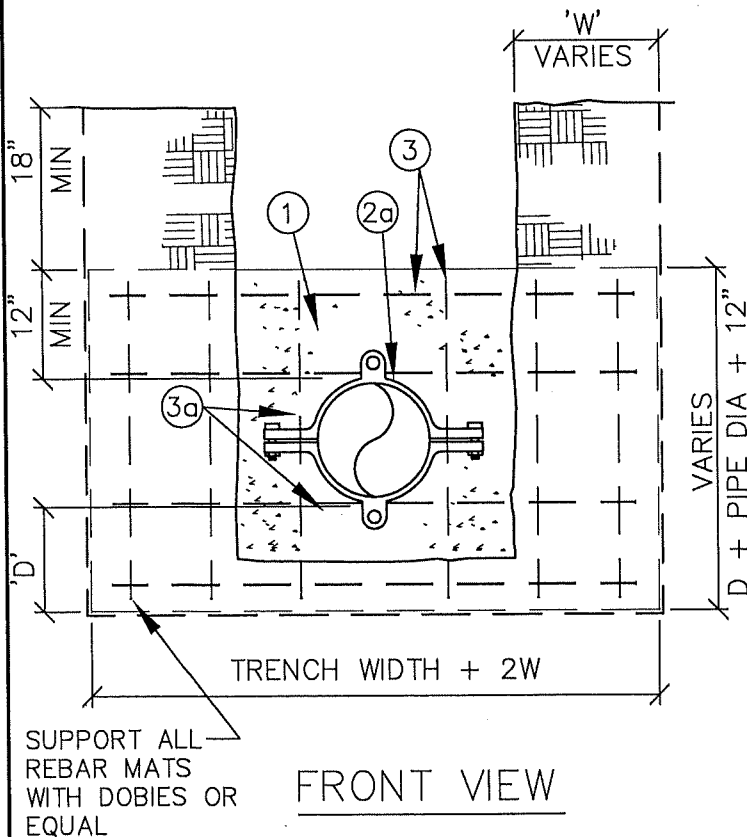

LAST REVISION DATE:
DEC 2021

COPYRIGHT 1996
WESTECH ENGINEERING, INC.

STRADDLE BLOCK FOR
WATERLINE PIPE &
PRESSURE SEWER PIPE

(NTS)

AUMSVILLE, OR

DETAIL NO.

511

NOTES:

1. GRAVITY VERTICAL THRUST BLOCKS SHALL BE DESIGNED BY THE ENGINEER.
2. **KEEP CONCRETE CLEAR OF JOINT AND JOINT ACCESSORIES. FITTINGS SHALL BE WRAPPED IN PLASTIC PRIOR TO PLACEMENT OF CONCRETE.**
3. CONCRETE THRUST BLOCKING SHALL BE POURED AGAINST UNDISTURBED EARTH.
4. CONCRETE MIX SHALL HAVE A MIN. 28 DAY STRENGTH OF 3000 P.S.I.
5. THRUST BLOCK VOLUMES FOR VERTICAL BENDS HAVING UPWARD RESULTANT THRUSTS ARE BASED ON TEST PRESSURE OF 150 P.S.I.G. AND THE WEIGHT OF CONCRETE = 4050 LBS./CU.YD.
6. VERTICAL BENDS THAT REQUIRE A THRUST BLOCK VOLUME EXCEEDING 5 CUBIC YARDS REQUIRE SPECIAL BLOCKING DETAILS. SEE PLANS FOR VOLUMES SHOWN INSIDE HEAVY LINE IN TABLE.
7. ALL REBAR SHALL BE GALVANIZED IN ACCORDANCE WITH ASTM-123 (MIN. 3.4 MIL). REBAR SHALL BE BENT BEFORE GALVANIZATION, AND LAST 4" OF BAR SHALL BE BENT 90 DEGREES WITH A 1/2" RADIUS BEND. REBAR SHALL BE TIGHTLY FIT TO RESTRAINED FITTING.
8. FOR HORIZONTAL THRUST BLOCK DETAILS SEE DRAWING NO. 510.

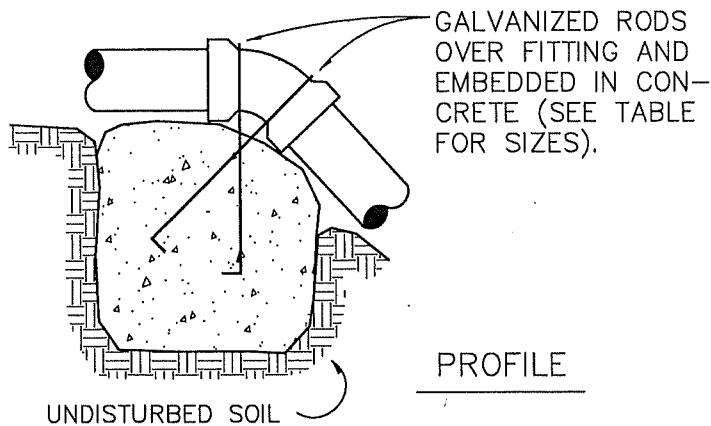

GRAVITY VERTICAL THRUST BLOCK

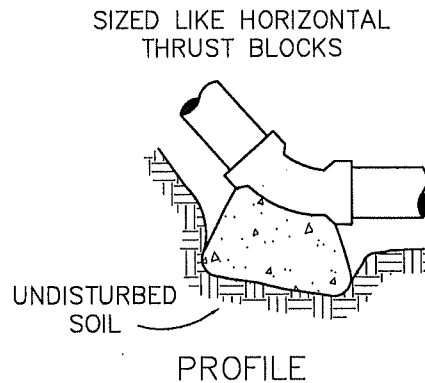

NORMAL VERTICAL THRUST BLOCK

VOLUME OF THRUST BLOCK IN CUBIC YARDS (VERTICAL BENDS)			
FITTING SIZE	BEND ANGLE		
	45°	22 1/2°	11 1/4°
4	1.1	0.4	0.2
6	2.7	1.0	0.4
8	4.0	1.5	0.6
10	6.0	2.3	0.9
12	8.5	3.2	1.3
14	11.5	4.3	1.8
16	14.8	5.6	2.3

FITTING SIZE	ROD SIZE	EMBEDMENT
12" AND LESS	#6	30"
14" - 16"	#8	36"

LAST REVISION DATE: FEB 2021	
VERTICAL THRUST BLOCKING	
(NTS)	
AUMSVILLE, OR	DETAIL NO. 512

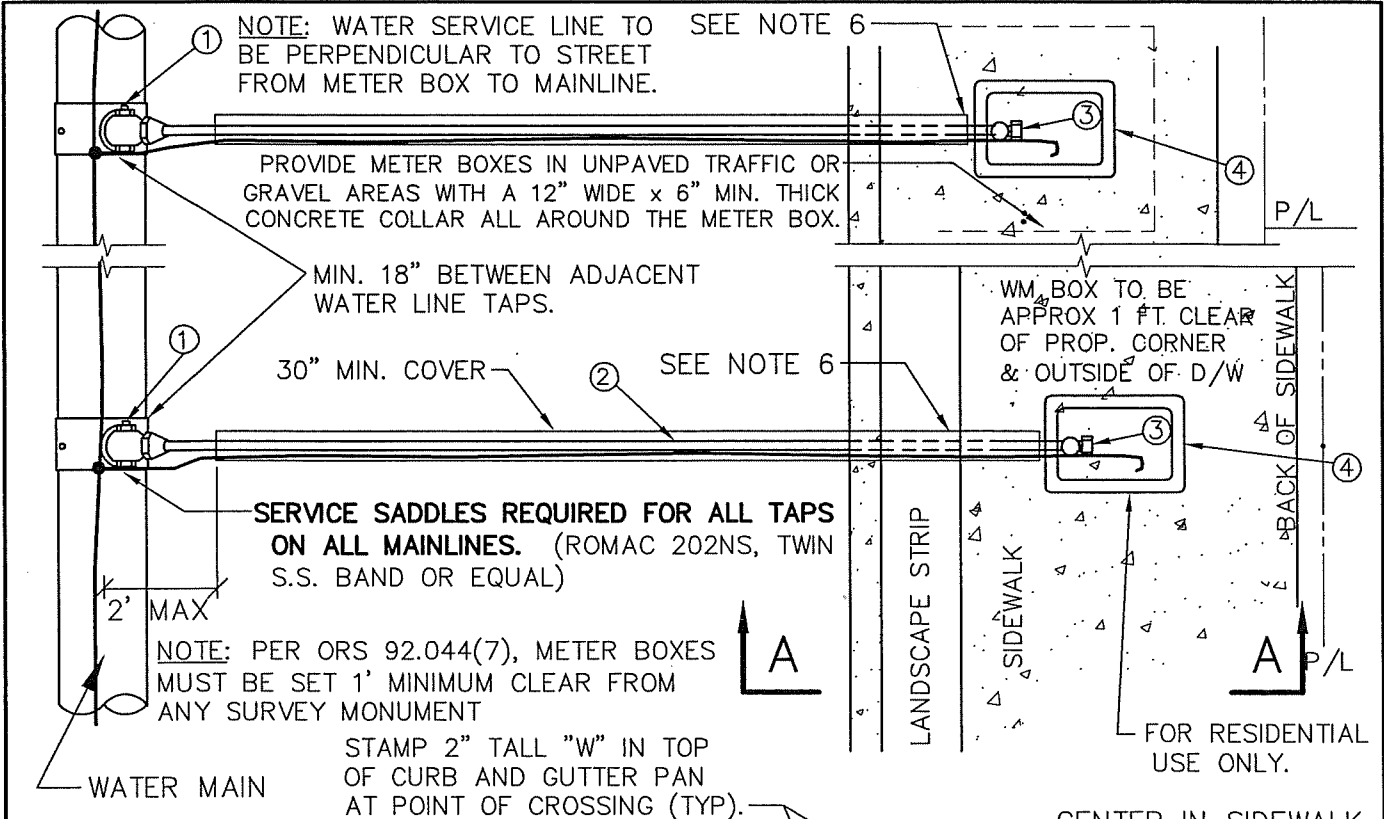

MATERIALS:

- ① 1" BALL STYLE CORPORATION STOP MUELLER 300 SERIES. SET AT 30° ANGLE UP FROM HORIZONTAL.
- ② 1" MUNIPEX BLUE XL-PE (CTS OD, SDR 9, 200 PSI) CONFORMING TO AWWA C904, USE 2-3/8" LONG INSERTS ON COMPRESSION FITTINGS (McDONALD 6133T). SINGLE RESIDENTIAL SERVICE: 1" TYP
- ③ 1" BALL STYLE LOCKING ANGLE METER STOP, MUELLER 300 SERIES OR EQUAL. PROVIDE ALL METER STOPS WITH 1" x 3/4" METER ADAPTER (FORD A24 OR EQUAL).
- ④ WATER METER BOX PER PWDS 5.8.h.1 (13"x24" ID, H20, GREY): -ARMORCAST A6001946PCX12 BODY W/A6001866 LID. PROVIDE METER BOXES WITH KNOCKOUTS FOR SENSOR HEADS.

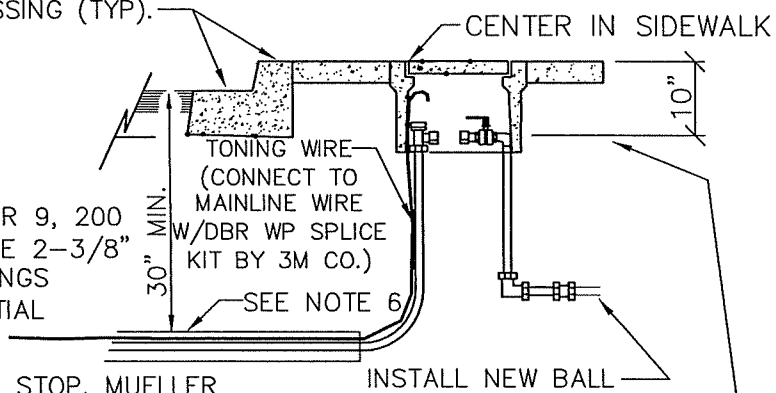

INSTALL NEW BALL VALVE, RISER & COUPLING FOR RELOCATED/REPLACED METER ASSEMBLIES.

SECTION A-A

NOTES:

- 1. SUBSTITUTES FOR ANY MATERIALS SHOWN SHALL BE APPROVED BY THE PUBLIC WORKS DIRECTOR.
- 2. ALL PIPE AND BACKFILL ZONES SHALL BE BACKFILLED USING 3/4" MINUS GRANULAR MATERIAL AND COMPACTED TO 92% MAX. DENSITY DETERMINED BY AASHTO T-180.
- 3. SET FRONT OF METER BOX BEHIND BACK OF SIDEWALK LOCATION AS SHOWN.
- 4. METER BOX SHALL BE CENTERED OVER THE COMPLETED METER ASSEMBLY.
- 5. 1 1/2"-INCH MIN. PIPE SIZE FOR COMMERCIAL SERVICES.
- 6. FAR SIDE COMMERCIAL SERVICES SHALL BE INSTALLED IN A 4" MIN DIA SCHED 40 PVC SLEEVE WHICH BEGINS 2' FROM MAIN AND EXTENDS TO BACK OF FAR SIDE SIDEWALK.
- 7. TRACER WIRE SPLICES SHALL USE USE WATERTIGHT CONNECTION, TYPE DBR DIRECT BURY SPLICE KIT BY 3M COMPANY (OR EQUAL).

METER COUPLING (TAIL), BALL VALVE W/HANDLE, COMPRESSION OUTLET & 90° ELBOW. PROVIDE PRIOR TO WATER METER INSTALLATION.

LAST REVISION DATE: JUNE 2023	COPYRIGHT 1986 WESTECH ENGINEERING, INC.
TYPICAL 1" WATER SERVICE (HDPE SERVICE LINE) (NTS)	
AUMSVILLE, OR	DETAIL NO. 515

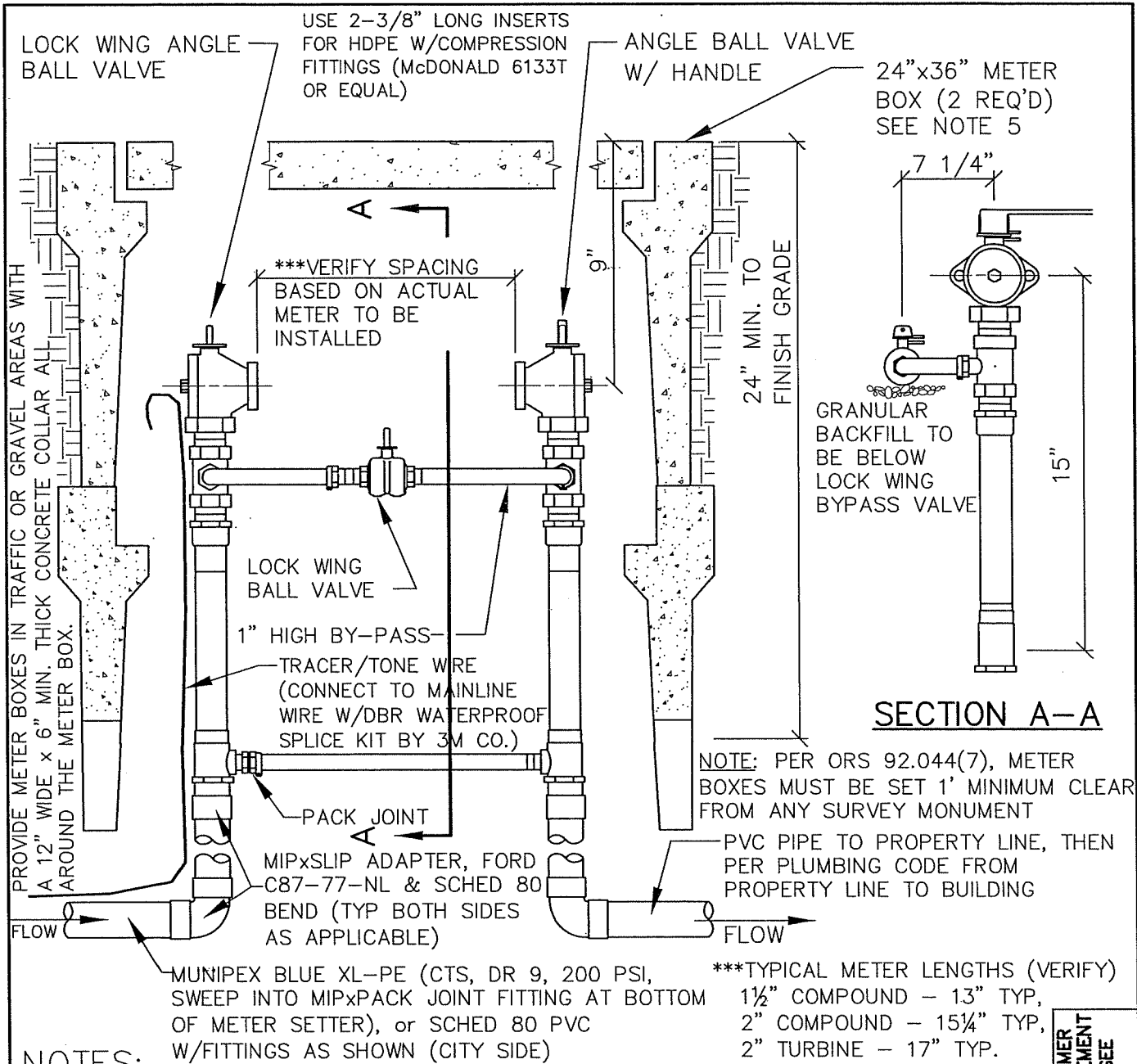

NOTES:

1. METERS SET TO BE FORD 70 SERIES COPPERSETTER, #VBB86-15HB-11-66 (1 1/2") OR #VBB87-15HB-11-77 (2") WITH RAISED LOCKING BYPASS OR APPROVED EQUAL.
2. SUBSTITUTES FOR ANY MATERIALS SHOWN SHALL BE APPROVED BY THE CITY ENGINEER.
3. ALL PIPE AND BACKFILL ZONES SHALL BE BACKFILLED USING 3/4" MINUS GRANULAR MATERIAL AND COMPACTED TO 92% OPTIMUM DENSITY PER AASHTO T-180.
4. SET FRONT OF METER BOX 3-INCHES BEHIND SIDEWALK (TYPICAL) FOR CURBLINE WALKS. NO METERS ON PRIVATE PROPERTY WITHOUT A RECORDED EASEMENT.
5. METER BOX SHALL BE CENTERED OVER THE COMPLETED METER ASSEMBLY. METER BOX PER PWDS 5.8.H.1 (24"x36" ID, H20, GREY)
 - ARMORCAST A6001974PCX12 BODY W/ A6001975 LID.
 - PROVIDE WITH KNOCKOUTS FOR SENSOR HEADS.
6. COPPERSETTER, METER BOX, & ALL FITTINGS PROVIDED BY CONTRACTOR. CONTRACTOR TO VERIFY DIMENSIONS & CLEARANCE BASED ON ACTUAL METER TO BE PROVIDED BY THE CITY. WATER METER INSTALLED BY CONTRACTOR UNDER CITY INSPECTION & APPROVAL.
7. SEE DETAIL 517 FOR TAPPING REQUIREMENTS.
8. **THREADED FEMALE PVC FITTINGS ARE NOT ALLOWED.**

***TYPICAL METER LENGTHS (VERIFY)
 1 1/2" COMPOUND - 13" TYP,
 2" COMPOUND - 15 1/4" TYP,
 2" TURBINE - 17" TYP.

USE OF PURPLE PVC PRIMER ON ALL PVC SOLVENT CEMENT JOINTS IS MANDATORY (SEE ALSO OPSC 605.12.2).

LAST REVISION DATE: DEC 2022	COPYRIGHT HESTECH ENGINEERING, INC.
1-1/2" AND 2" METER SET W/1" HIGH BY-PASS (HDPE or PVC SERVICE LINE) (NTS)	
AUMSVILLE, OR	DETAIL NO. 516

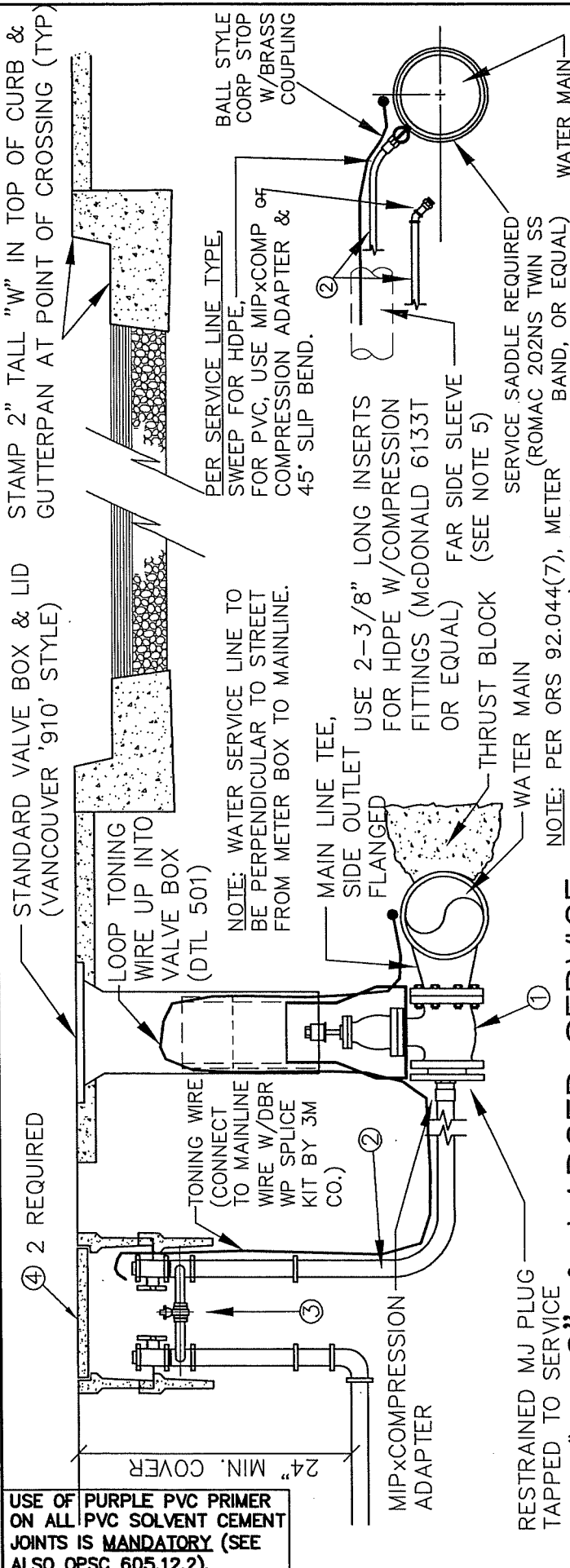

USE OF PURPLE PVC PRIMER ON ALL PVC SOLVENT CEMENT JOINTS IS MANDATORY (SEE ALSO OPSC 605.12.2).

NOTE: WATER SERVICE LINE TO BE PERPENDICULAR TO STREET FROM METER BOX TO MAINLINE.

NOTE: PER ORS 92.044(7), METER BOXES MUST BE SET 1' MINIMUM CLEAR FROM ANY SURVEY MONUMENT

2" & LARGER SERVICE

MATERIALS

- ① FLG X MJ RESILIENT WEDGE GATE VALVE PER AWWA C-509. 4" DIA. OR SERVICE SIZE, WHICHEVER IS LARGER. EPOXY COATED PER AWWA C-550.
- ② MUNIPEX BLUE XL-PE (CTS, DR 9, 200 PSI, ≤2"φ) W/OUT JOINTS OR SCHEDULE 80 PVC PIPE & FITTINGS PER DETAIL 516 (30" MIN COVER TO METER). **FEMALE THREADED PVC FITTINGS ARE NOT ALLOWED.** FOR SERVICES >2"φ, USE CL 52 DI PIPE. FOR SERVICES ≤2"φ, SEE DTL 516 FOR CONFIG. AT METER BOX.
- ③ METER STOP ASSEMBLY W/BYPASS PER PUBLIC WORKS REQUIREMENTS. SEE DETAIL 516 FOR 1-1/2" & 2" SERVICES (DTL 523-526 FOR LARGER).
- ④ METER BOX FOR 1-1/2" AND 2" SHALL BE PER DETAIL 516. USE TRAFFIC RATED VERSION OF BOX/LID FOR TRAFFIC AREAS. METER VAULT FOR LARGER SERVICE PER PUBLIC WORKS REQUIREMENTS. PROVIDE WITH KNOCKOUT FOR SENSOR HEADS.

1-1/2" SERVICE

NOTES

- 1. SUBSTITUTES FOR ANY MATERIAL SHOWN SHALL BE APPROVED BY THE CITY ENGINEER.
- 2. ALL PIPE AND STRUCTURE ZONES SHALL BE BACKFILLED USING 3/4" MINUS GRANULAR MATERIAL AND COMPACTED TO 95% MAX DENSITY AS DETERMINED BY ASHTO T-180.
- 3. METER BOX SHALL BE CENTERED OVER THE COMPLETED METER AND FITTING ASSEMBLY. CUSTOMER SHALL INSTALL AN APPROVED BACKFLOW PREVENTION DEVICE ON PRIVATE PROPERTY IMMEDIATELY DOWNSTREAM OF WATER METER IF REQUIRED BY PUBLIC WORKS.
- 5. FAR SIDE COMMERCIAL SERVICES SHALL BE INSTALLED IN A 4" MIN DIA SCHED 40 PVC SLEEVE WHICH BEGINS 2' FROM MAIN AND EXTENDS TO BACK OF FAR SIDE SIDEWALK.
- 7. METER BOXES IN TRAFFIC OR GRAVEL AREAS SHALL PROVIDED WITH A 12" WIDE x 6" MIN. THICK CONCRETE COLLAR ALL AROUND THE METER BOX.

LAST REVISION DATE: MAY 2023	COPYRIGHT WESTECH ENGINEERING, INC.
TAPPING REQUIREMENTS, 1-1/2" AND LARGER SERVICE (HDPE or PVC SERVICE LINE)	
(NTS)	
AUMSVILLE, OR	DETAIL NO. 517

1" ALUMINUM SCREENED TEE VENT
(DOWN ORIENTED DOUBLE OUTLET)
(MORRISON MR 155 OR EQUAL),
MOUNT WITH SCREEN 12" MINIMUM
ABOVE GRADE.

17"X30" ARMORCAST
METER BOX W/LID

1"x3" BRASS NIPPLE

1/2"x1" 90° BEND.

1" A.R.I D-040-C
COMB. AIR/VAC
VALVE (DUCTILE IRON
BODY) OR EQUAL

17"X30" ARMORCAST
METER BOX W/OUT LID

1" XL-PE PIPE W/OUT
JOINTS, SEE NOTE BELOW

90° ELL,
BRASS OR
BRONZE

5% MIN.
SLOPE

SERVICE
SADDLE PER
DETAIL 515

1" BALL STYLE
CORPORATION STOP
MUELLER 300 SERIES OR
APPROVED EQUAL (ORIENT
NUT ON HORIZONTAL CORP
STOP TO FACE UPWARD)

1" BRASS OR
COPPER PIPE,
LENGTH VARIES

1" BRASS
UNION

4" or 6" φ PIPE BOLLARD
PER DTIL 226. LOCATION PER
PLANS (2 WHERE REQ'D TO
PROTECT METER BOX,
PAINT BLUE FOR POTABLE
WATER, SEE NOTE 2).

SECURE TO BOLLARD
WITH 1"x1/8" STAINLESS
STEEL CLAMP & BOLT
PER DETAIL @ LEFT.

PYLWOOD FORM &
PLASTIC AS REQUIRED
TO AVOID CONCRETE
ENCASEMENT OF RISER
PIPE.

ORIENTATION OF VENT PIPE
THROUGH BOX WALL AS
SHOWN ON PLANS OR AS
DIRECTED (ORIENTATION ON
DETAIL IS FOR CLARITY).

1" BRASS
90° ELL

1" BRASS OR
COPPER PIPE

1" BRASS NIPPLE &
COUPLING

1" BRASS 90° ELL

1"x3" BRASS NIPPLE

1" BRASS COUPLING

CONCRETE SUPPORT BLOCK

COMPACTED 3/4"-0
GRAVEL, 12" THICK (MIN)

PIPE NOTE. MUNIPEX BLUE XL-PE (CTS OD, SDR 9,
200 PSI) CONFORMING TO AWWA C904, USE 2-3/8"
LONG INSERTS ON COMPRESSION FITTINGS (McDONALD
6133T).

NOTES:

1. RISER SHALL BE PROTECTED FROM VEHICULAR OR PEDESTRIAN TRAFFIC AS APPROVED BY THE CITY ENGINEER & PUBLIC WORKS.
2. PAINT BOLLARD & TOP SAFETY BLUE FOR POTABLE WATER APPLICATIONS.
3. WHERE ARV ASSEMBLIES ARE INSTALLED ADJACENT TO FENCES, BOLLARDS SHALL BE SET 3" MIN CLEAR FROM FENCE UNLESS OTHERWISE APPROVED BY PROPERTY OWNER.
4. EXACT LOCATION OF RISER PENTRATION THROUGH BOX & BOLLARDS TO BE VERIFIED IN FIELD WITH CITY ENGINEER & PUBLIC WORKS PRIOR TO RISER & BOLLARD INSTALLATION.

LAST REVISION DATE:

JULY 2021

JO #

1" COMBINATION AIR
RELEASE VALVE
(CARV)
(NTS)

DETAIL NO.

AUMSVILLE, OR

518

NOTES:

- METER VAULT & PIPING SHALL CONFORM TO REQUIREMENTS OF ALL PUBLIC/PRIVATE AGENCIES HAVING JURISDICTION.
- METER VAULT SHALL BE PLACED WITHIN RIGHT-OF-WAY UNLESS OTHERWISE APPROVED (RECORDED EASEMENT TO THE CITY REQUIRED FOR ANY METER ON PRIVATE PROPERTY).
- ALL MATERIALS (EXCEPT THE METER) SHALL BE FURNISHED & INSTALLED BY THE CONTRACTOR. THE CONTRACTOR SHALL INSTALL A TEMPORARY SPACER SPOOL BETWEEN METER ISOLATION VALVES FOR TESTING. THE TEMPORARY SPACER SPOOL SHALL MATCH THE LENGTH OF THE ACTUAL METER TO BE PROVIDED BY THE CITY.
- PIPING INSIDE VAULT & THROUGH WALLS TO BE CL 52 DUCTILE IRON, EXCEPT AS OTHERWISE SHOWN.
- METER WILL BE SUPPLIED BY THE CITY, BUT SHALL BE INSTALLED (AFTER PRESSURE & OTHER TESTING OF METER VAULT PIPING) BY THE CONTRACTOR UNDER CITY INSPECTION AND APPROVAL.
- ISOLATION VALVES IN METER VAULT SHALL BE NON-RISING STEM GATE VALVE (EPOXY COATED) WITH 2-INCH SQUARE OPERATING NUT.
- ALL MJ CONNECTIONS (INCLUDING BYPASS LINE FITTINGS) SHALL BE ASSEMBLED WITH RETAINER GLANDS (EBBA MEGA-LUGS OR APPROVED EQUAL). ROMAC ALPHA FC ALLOWED AS EQUAL FOR HYMAX GRIP FC.
- ALL PIPE OPENINGS SHALL BE CORE DRILLED (REGARDLESS OF PRESENCE OF 'KNOCKOUTS'), AND SEALED WATERTIGHT WITH NON-SHRINK GROUT.
- PIPE SUPPORTS SHALL BE GALVANIZED STANDON S89 OR APPROVED EQUAL AT EACH ISOLATION VALVE AND AT BYPASS VALVE.
- METER VAULT TO BE UTILITY VAULT 687-WA OR APPROVED EQUAL, CONFORMING WITH ASTM C-857. PROVIDE ALUMINUM ANGLE FRAME HATCH (48"x 72" MIN) BY USF FABRICATION OR APPROVED EQUAL (HATCH COVER TOP TO BE SAND BLASTED NON-SLIP).
 - TO BE 300 PSF PEDESTRIAN RATED WHERE LID IS SET MIN. OF 9" ABOVE GRADE.
 - TO BE H-20 RATED IF LID IS LESS THAN 9" ABOVE GRADE, OR IF LOCATED IN TRAFFIC AREA.
- METER VAULT SHALL BE PROVIDED WITH AN OSHA APPROVED GALVANIZED STEEL LADDER AND ALUMINUM LADDER SAFETY EXTENSION. ATTACH TO VAULT WITH STAINLESS STEEL BOLTS.
- CONTRACTOR TO INSTALL SUMP PUMP (5 GPM MIN) WITH 120V POWER SUPPLY, ALONG WITH PRIVATE POWER SOURCE (RESPONSIBILITY OF CONTRACTOR INSTALLING VAULT). SCHED 40 CONDUIT, WIRE, ETC. FOR SUMP PUMP POWER SHALL CONFORM WITH NEC REQUIREMENTS.
- SUMP PUMP DISCHARGE PIPE SHALL BE 1½-INCH SCHEDULE 40 PVC, PROVIDED WITH UNION (FOR PUMP REMOVAL), CHECK VALVE AND ISOLATION BALL VALVE. CONNECT DISCHARGE TO GRAVITY STORM DRAIN OR CURB WEEP HOLE (AT LOCATION APPROVED BY PUBLIC WORKS).
- SUMP TO BE 18" ROUND CONCRETE PIPE OR EQUAL. PROVIDE FRP GRATE (OR SLOTTED MH LID) WITH COPED CUTOUT FOR DISCHARGE PIPING (IE. LID TO BE REMOVABLE WITHOUT DISASSEMBLING DISCHARGE PIPING). SUMP TO BE LARGE ENOUGH & DEEP ENOUGH TO HOUSE PUMP & FLOAT, AND KEEP WATER LEVEL BELOW SLOPED FLOOR.

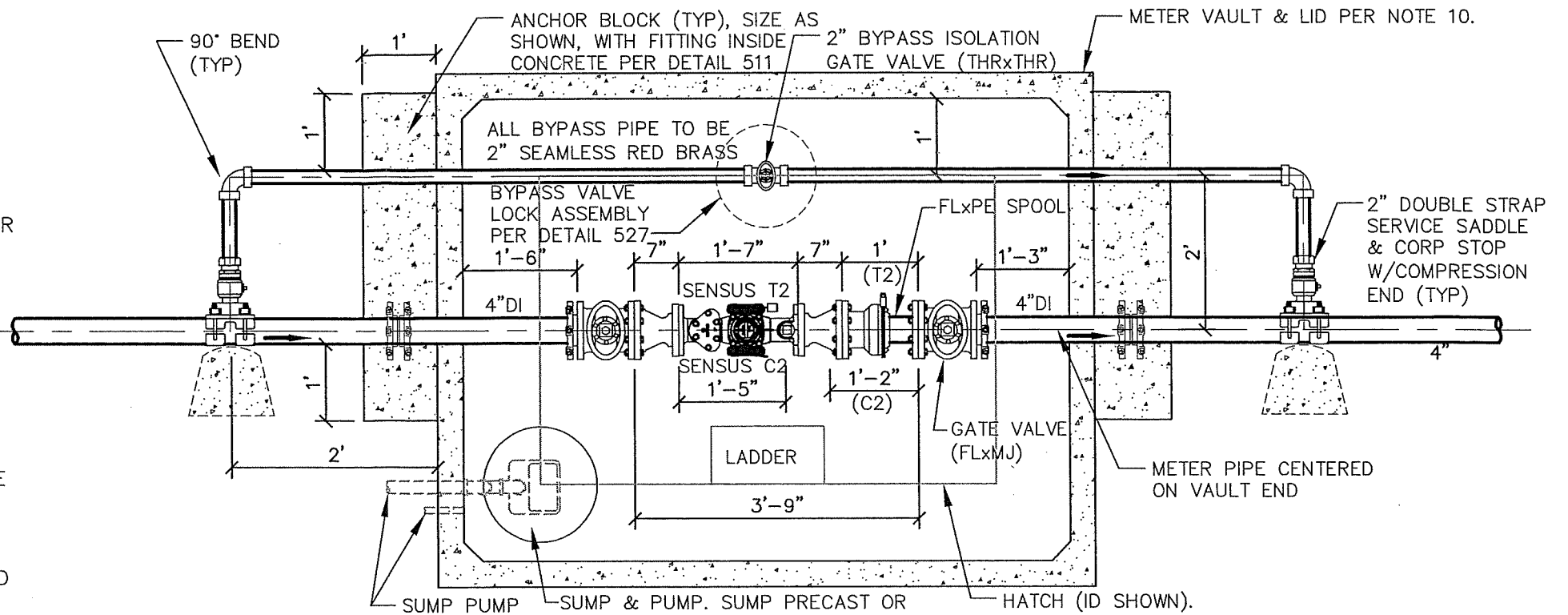

PLAN
NTS

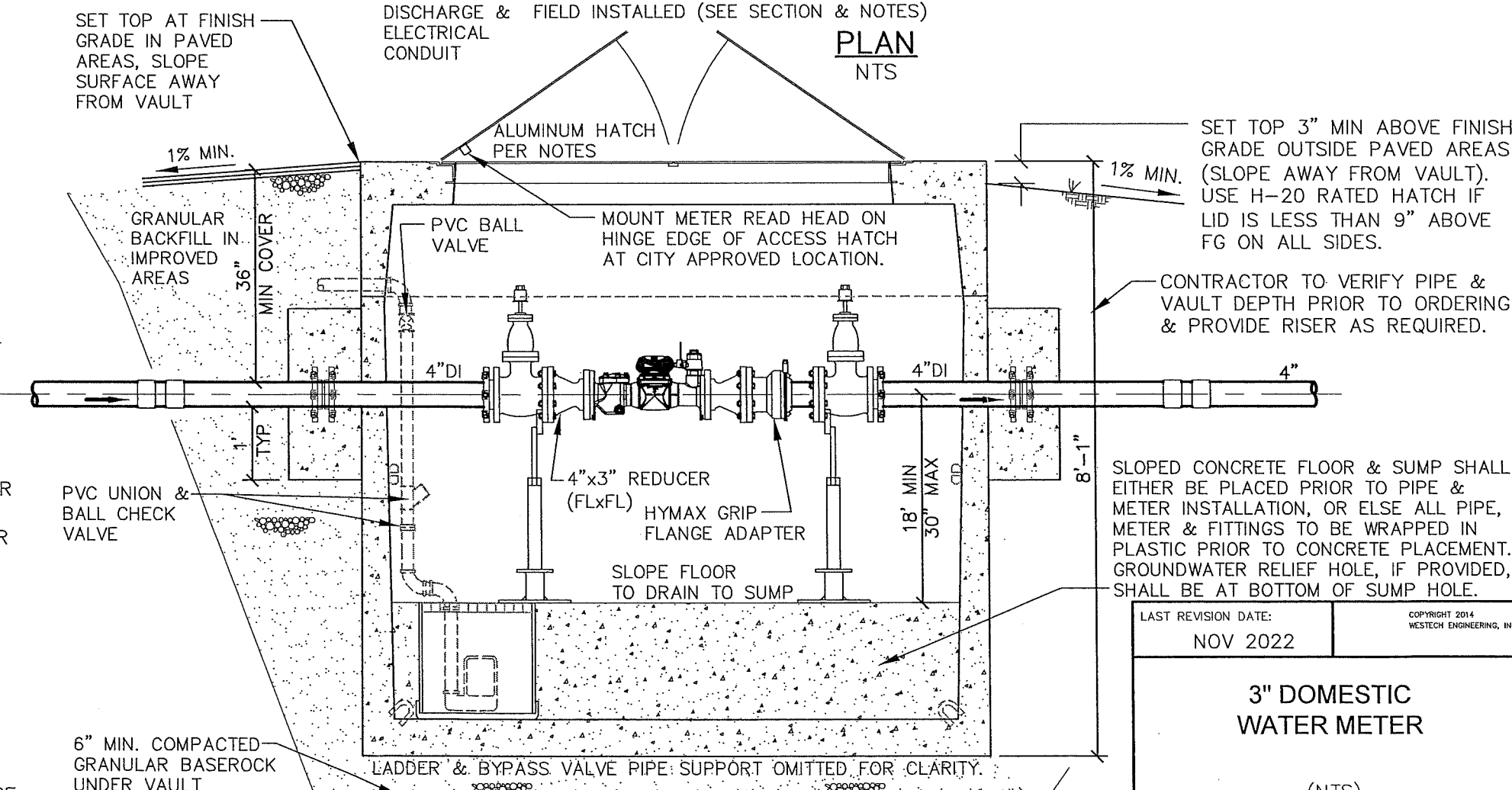

SECTION
NTS

LAST REVISION DATE: NOV 2022	COPYRIGHT 2014 WESTECH ENGINEERING, INC.
3" DOMESTIC WATER METER	
(NTS)	
AUMSVILLE, OR	DETAIL NO. 523

NOTES:

1. METER VAULT & PIPING SHALL CONFORM TO REQUIREMENTS OF ALL PUBLIC/PRIVATE AGENCIES HAVING JURISDICTION.
2. METER VAULT SHALL BE PLACED WITHIN RIGHT-OF-WAY UNLESS OTHERWISE APPROVED (RECORDED EASEMENT TO THE CITY REQUIRED FOR ANY METER ON PRIVATE PROPERTY).
3. ALL MATERIALS (EXCEPT THE METER) SHALL BE FURNISHED & INSTALLED BY THE CONTRACTOR. THE CONTRACTOR SHALL INSTALL A TEMPORARY SPACER SPOOL BETWEEN METER ISOLATION VALVES FOR TESTING. THE TEMPORARY SPOOL SHALL MATCH THE LENGTH OF THE ACTUAL METER TO BE PROVIDED BY THE CITY.
4. PIPING INSIDE VAULT & THROUGH WALLS TO BE CL 52 DUCTILE IRON, EXCEPT AS OTHERWISE SHOWN.
5. METER WILL BE SUPPLIED BY THE CITY, BUT SHALL BE INSTALLED (AFTER PRESSURE & OTHER TESTING OF METER VAULT PIPING) BY THE CONTRACTOR UNDER CITY INSPECTION AND APPROVAL.
6. ISOLATION VALVES IN METER VAULT SHALL BE NON-RISING STEM GATE VALVE (EPOXY COATED) WITH 2-INCH SQUARE OPERATING NUT.
7. ALL MJ CONNECTIONS (INCLUDING BYPASS LINE FITTINGS) SHALL BE ASSEMBLED WITH RETAINER GLANDS (EBBA MEGA-LUGS OR APPROVED EQUAL). ROMAC ALPHA FC ALLOWED AS EQUAL FOR HYMAX GRIP FC.
8. ALL PIPE OPENINGS SHALL BE CORE DRILLED (REGARDLESS OF PRESENCE OF 'KNOCKOUTS'), AND SEALED WATERTIGHT WITH NON-SHRINK GROUT.
9. PIPE SUPPORTS SHALL BE GALVANIZED STANDON S89 OR APPROVED EQUAL AT EACH ISOLATION VALVE AND AT BYPASS VALVE.
10. METER VAULT TO BE UTILITY VAULT 687-WA OR APPROVED EQUAL, CONFORMING WITH ASTM C-857. PROVIDE ALUMINUM ANGLE FRAME HATCH (48"x 72" MIN) BY USF FABRICATION OR APPROVED EQUAL (HATCH COVER TOP TO BE SAND BLASTED NON-SLIP).
 - (1) TO BE 300 PSF PEDESTRIAN RATED WHERE LID IS SET MIN. OF 9" ABOVE GRADE.
 - (2) TO BE H-20 RATED IF LID IS LESS THAN 9" ABOVE GRADE, OR IF LOCATED IN TRAFFIC AREA.
11. METER VAULT SHALL BE PROVIDED WITH AN OSHA APPROVED GALVANIZED STEEL LADDER AND ALUMINUM LADDER SAFETY EXTENSION. ATTACH TO VAULT WITH STAINLESS STEEL BOLTS.
12. CONTRACTOR TO INSTALL SUMP PUMP (5 GPM MIN) WITH 120V POWER SUPPLY, ALONG WITH PRIVATE POWER SOURCE (RESPONSIBILITY OF CONTRACTOR INSTALLING VAULT). SCHED 40 CONDUIT, WIRE, ETC. FOR SUMP PUMP POWER SHALL CONFORM WITH NEC REQUIREMENTS.
13. SUMP PUMP DISCHARGE PIPE SHALL BE 1½-INCH SCHEDULE 40 PVC, PROVIDED WITH UNION (FOR PUMP REMOVAL), CHECK VALVE AND ISOLATION BALL VALVE. CONNECT DISCHARGE TO GRAVITY STORM DRAIN OR CURB WEEP HOLE (AT LOCATION APPROVED BY PUBLIC WORKS).
14. SUMP TO BE 18" ROUND CONCRETE PIPE OR EQUAL. PROVIDE FRP GRATE (OR SLOTTED MH LID) WITH COPED CUTOUT FOR DISCHARGE PIPING (IE. LID TO BE REMOVABLE WITHOUT DISASSEMBLING DISCHARGE PIPING). SUMP TO BE LARGE ENOUGH & DEEP ENOUGH TO HOUSE PUMP & FLOAT, AND KEEP WATER LEVEL BELOW SLOPED FLOOR.

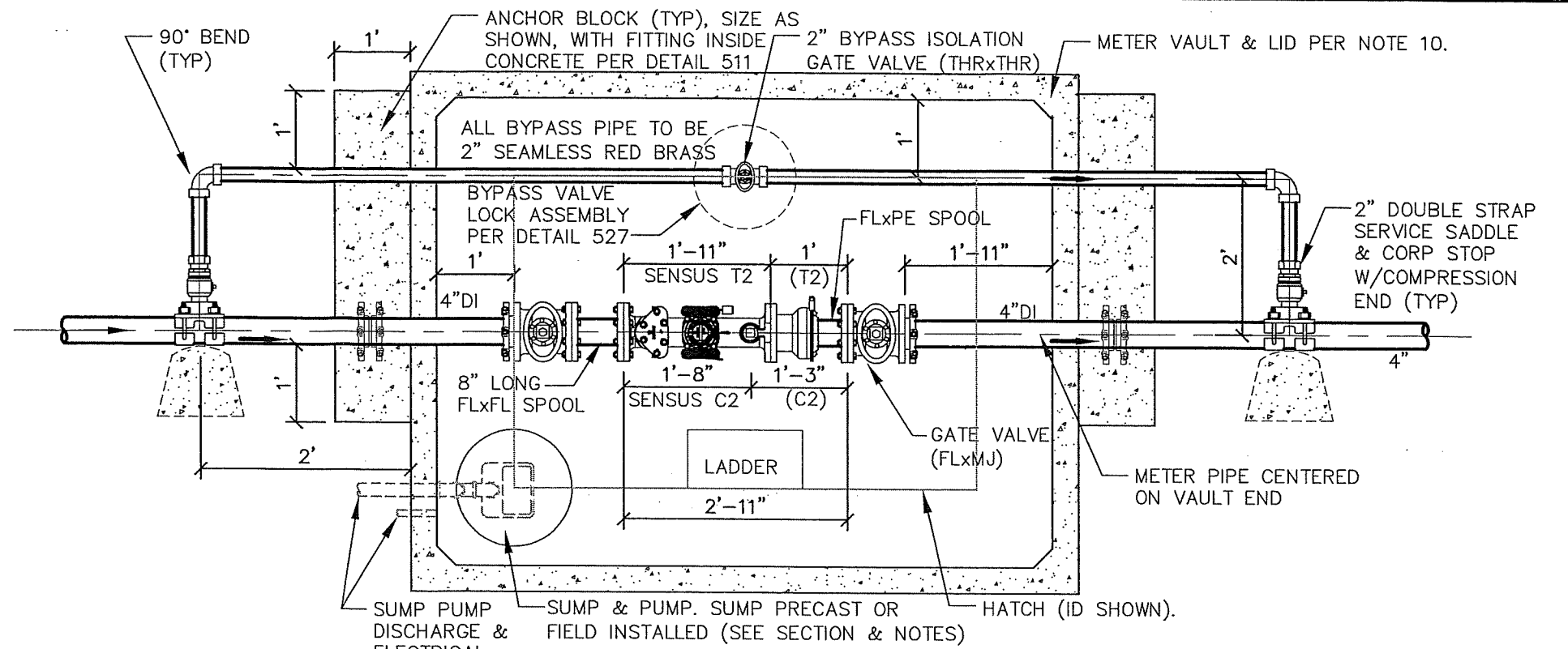

PLAN
NTS

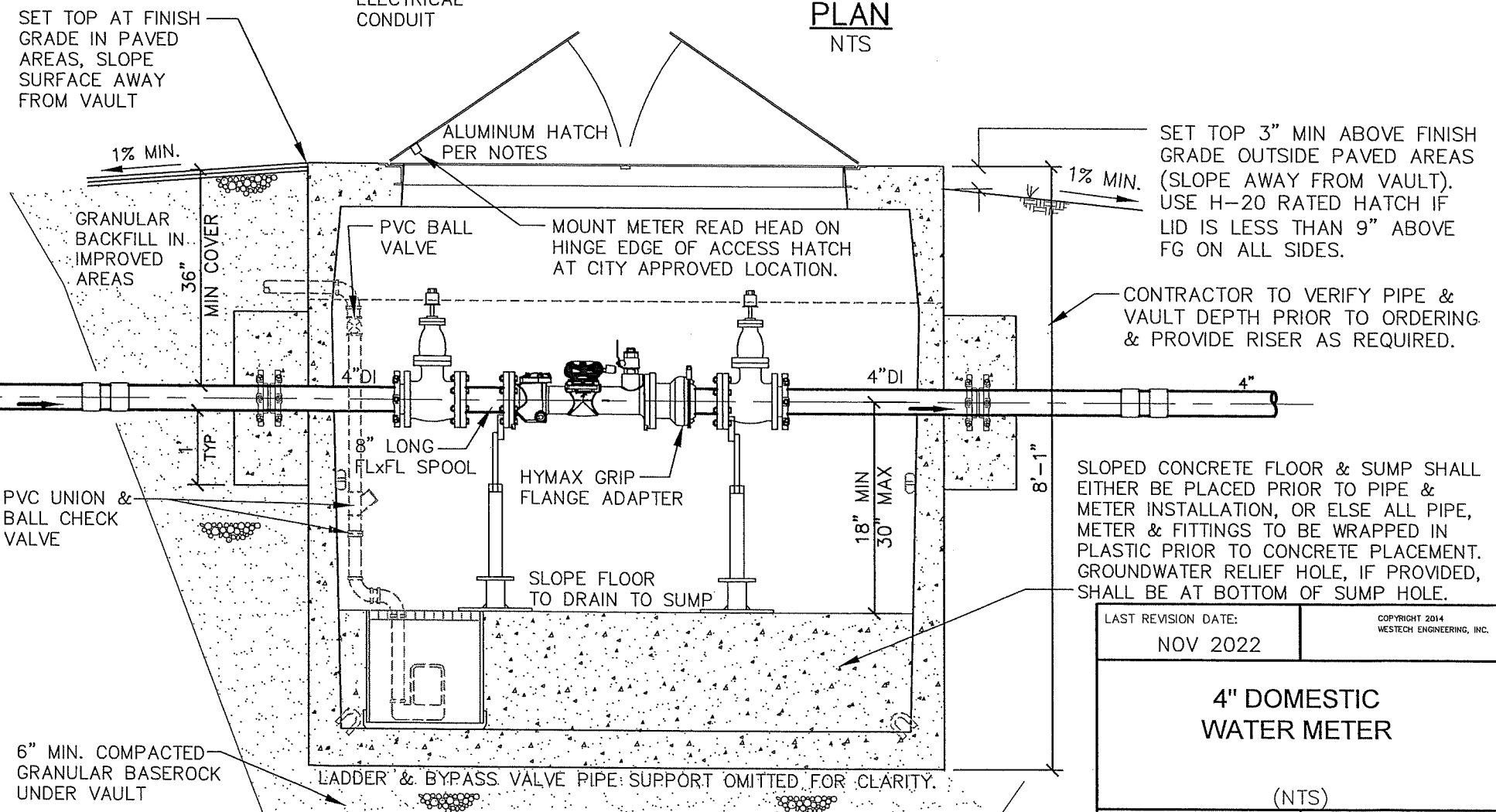

SECTION
NTS

LAST REVISION DATE: NOV 2022	COPYRIGHT 2014 WESTECH ENGINEERING, INC.
4" DOMESTIC WATER METER	
(NTS)	
AUMSVILLE, OR	DETAIL NO. 524

NOTES:

1. METER VAULT & PIPING SHALL CONFORM TO REQUIREMENTS OF ALL PUBLIC/PRIVATE AGENCIES HAVING JURISDICTION.
2. METER VAULT SHALL BE PLACED WITHIN RIGHT-OF-WAY UNLESS OTHERWISE APPROVED (RECORDED EASEMENT TO THE CITY REQUIRED FOR ANY METER ON PRIVATE PROPERTY).
3. ALL MATERIALS (EXCEPT THE METER) SHALL BE FURNISHED & INSTALLED BY THE CONTRACTOR. THE CONTRACTOR SHALL INSTALL A TEMPORARY SPACER SPOOL BETWEEN METER ISOLATION VALVES FOR TESTING. THE TEMPORARY SPOOL SHALL MATCH THE LENGTH OF THE ACTUAL METER TO BE PROVIDED BY THE CITY.
4. PIPING INSIDE VAULT & THROUGH WALLS TO BE CL 52 DUCTILE IRON, EXCEPT AS OTHERWISE SHOWN.
5. METER WILL BE SUPPLIED BY THE CITY, BUT SHALL BE INSTALLED (AFTER PRESSURE & OTHER TESTING OF METER VAULT PIPING) BY THE CONTRACTOR UNDER CITY INSPECTION AND APPROVAL.
6. ISOLATION VALVES IN METER VAULT SHALL BE NON-RISING STEM GATE VALVE (EPOXY COATED) WITH 2-INCH SQUARE OPERATING NUT.
7. ALL MJ CONNECTIONS (INCLUDING BYPASS LINE FITTINGS) SHALL BE ASSEMBLED WITH RETAINER GLANDS (EBBA MEGA-LUGS OR APPROVED EQUAL). ROMAC ALPHA FC ALLOWED AS EQUAL FOR HYMAX GRIP FC.
8. ALL PIPE OPENINGS SHALL BE CORE DRILLED (REGARDLESS OF PRESENCE OF 'KNOCKOUTS'), AND SEALED WATERTIGHT WITH NON-SHRINK GROUT.
9. PIPE SUPPORTS SHALL BE GALVANIZED STANDON S89 OR APPROVED EQUAL AT EACH ISOLATION VALVE AND AT BYPASS VALVE.
10. METER VAULT TO BE UTILITY VAULT 687-WA OR APPROVED EQUAL, CONFORMING WITH ASTM C-857. PROVIDE ALUMINUM ANGLE FRAME HATCH (48"x 72" MIN) BY USF FABRICATION OR APPROVED EQUAL (HATCH COVER TOP TO BE SAND BLASTED NON-SLIP).
 - (1) TO BE 300 PSF PEDESTRIAN RATED WHERE LID IS SET MIN. OF 9" ABOVE GRADE.
 - (2) TO BE H-20 RATED IF LID IS LESS THAN 9" ABOVE GRADE, OR IF LOCATED IN TRAFFIC AREA.
11. METER VAULT SHALL BE PROVIDED WITH AN OSHA APPROVED GALVANIZED STEEL LADDER AND ALUMINUM LADDER SAFETY EXTENSION. ATTACH TO VAULT WITH STAINLESS STEEL BOLTS.
12. CONTRACTOR TO INSTALL SUMP PUMP (5 GPM MIN) WITH 120V POWER SUPPLY, ALONG WITH PRIVATE POWER SOURCE (RESPONSIBILITY OF CONTRACTOR INSTALLING VAULT). SCHED 40 CONDUIT, WIRE, ETC. FOR SUMP PUMP POWER SHALL CONFORM WITH NEC REQUIREMENTS.
13. SUMP PUMP DISCHARGE PIPE SHALL BE 1½-INCH SCHEDULE 40 PVC, PROVIDED WITH UNION (FOR PUMP REMOVAL), CHECK VALVE AND ISOLATION BALL VALVE. CONNECT DISCHARGE TO GRAVITY STORM DRAIN OR CURB WEEP HOLE (AT LOCATION APPROVED BY PUBLIC WORKS).
14. SUMP TO BE 18" ROUND CONCRETE PIPE OR EQUAL. PROVIDE FRP GRATE (OR SLOTTED MH LID) WITH COPED CUTOUT FOR DISCHARGE PIPING (IE. LID TO BE REMOVABLE WITHOUT DISASSEMBLING DISCHARGE PIPING). SUMP TO BE LARGE ENOUGH & DEEP ENOUGH TO HOUSE PUMP & FLOAT, AND KEEP WATER LEVEL BELOW SLOPED FLOOR.

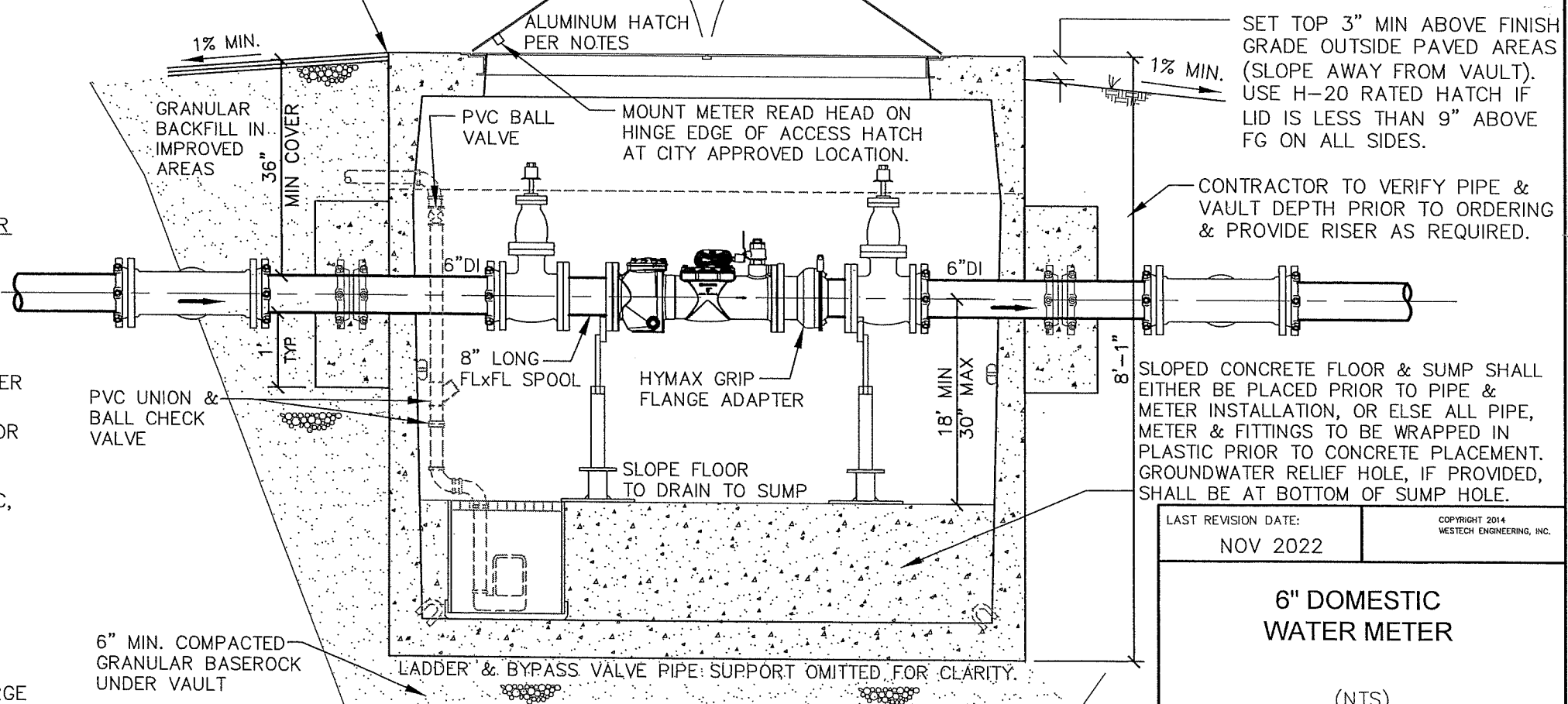
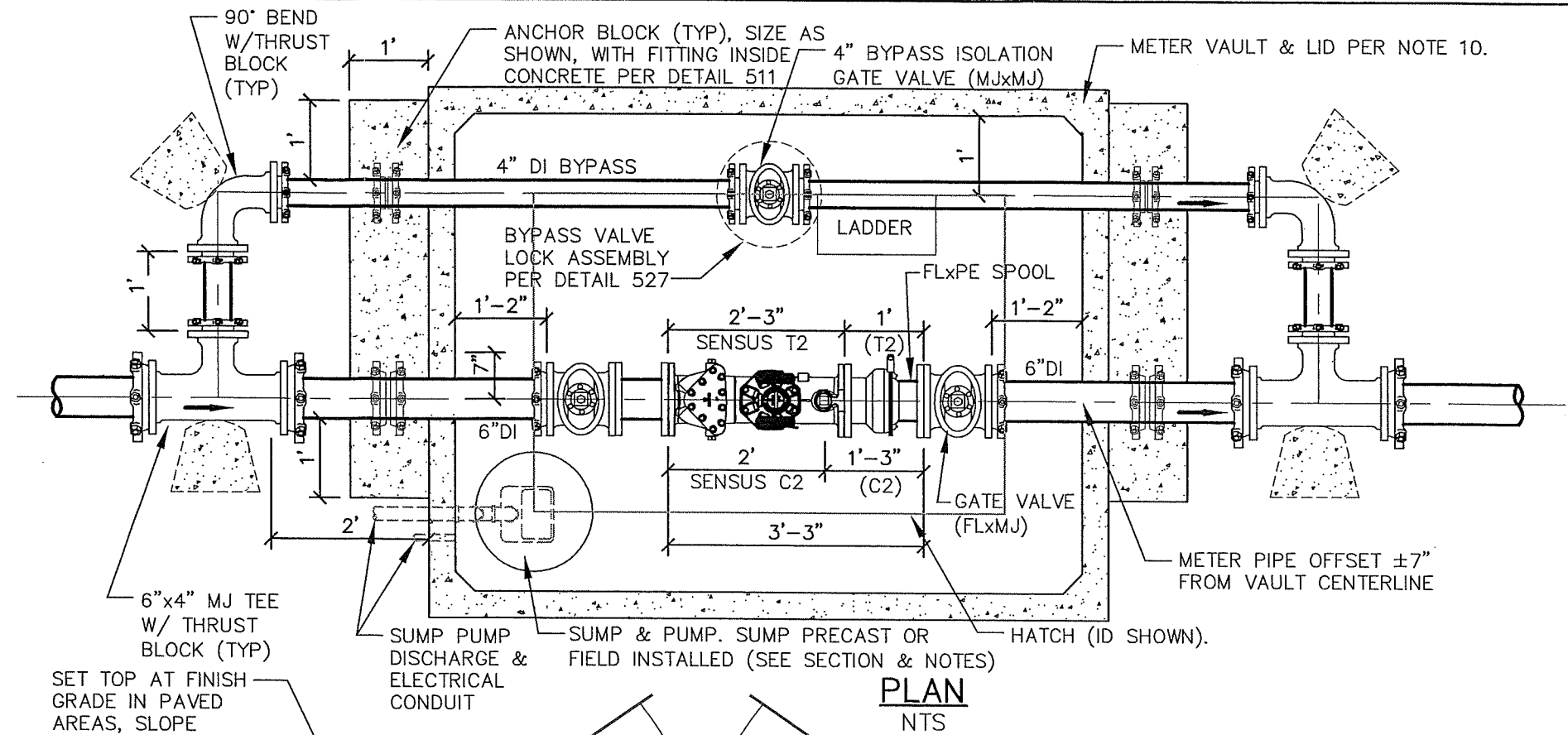

SECTION
NTS

PLAN
NTS

LAST REVISION DATE: NOV 2022	COPYRIGHT 2014 WESTECH ENGINEERING, INC.
6" DOMESTIC WATER METER	
(NTS)	
AUMSVILLE, OR	DETAIL NO. 525

NOTES:

1. METER VAULT & PIPING SHALL CONFORM TO REQUIREMENTS OF ALL PUBLIC/PRIVATE AGENCIES HAVING JURISDICTION.
2. METER VAULT SHALL BE PLACED WITHIN RIGHT-OF-WAY UNLESS OTHERWISE APPROVED (RECORDED EASEMENT TO THE CITY REQUIRED FOR ANY METER ON PRIVATE PROPERTY).
3. ALL MATERIALS (EXCEPT THE METER) SHALL BE FURNISHED & INSTALLED BY THE CONTRACTOR. THE CONTRACTOR SHALL INSTALL A TEMPORARY SPACER SPOOL BETWEEN METER ISOLATION VALVES FOR TESTING. THE TEMPORARY SPOOL SHALL MATCH THE LENGTH OF THE ACTUAL METER TO BE PROVIDED BY THE CITY.
4. PIPING INSIDE VAULT & THROUGH WALLS TO BE CL 52 DUCTILE IRON, EXCEPT AS OTHERWISE SHOWN.
5. METER WILL BE SUPPLIED BY THE CITY, BUT SHALL BE INSTALLED (AFTER PRESSURE & OTHER TESTING OF METER VAULT PIPING) BY THE CONTRACTOR UNDER CITY INSPECTION AND APPROVAL.
6. ISOLATION VALVES IN METER VAULT SHALL BE NON-RISING STEM GATE VALVE (EPOXY COATED) WITH 2-INCH SQUARE OPERATING NUT.
7. ALL MJ CONNECTIONS (INCLUDING BYPASS LINE FITTINGS) SHALL BE ASSEMBLED WITH RETAINER GLANDS (EBBA MEGA-LUGS OR APPROVED EQUAL). ROMAC ALPHA FC ALLOWED AS EQUAL FOR HYMAX GRIP FC.
8. ALL PIPE OPENINGS SHALL BE CORE DRILLED (REGARDLESS OF PRESENCE OF 'KNOCKOUTS'), AND SEALED WATERTIGHT WITH NON-SHRINK GROUT.
9. PIPE SUPPORTS SHALL BE GALVANIZED STANDON S89 OR APPROVED EQUAL AT EACH ISOLATION VALVE AND AT BYPASS VALVE.
10. METER VAULT TO BE UTILITY VAULT 687-WA OR APPROVED EQUAL, CONFORMING WITH ASTM C-857. PROVIDE ALUMINUM ANGLE FRAME HATCH (48"x 72" MIN) BY USF FABRICATION OR APPROVED EQUAL (HATCH COVER TOP TO BE SAND BLASTED NON-SLIP).
 - (1) TO BE 300 PSF PEDESTRIAN RATED WHERE LID IS SET MIN. OF 9" ABOVE GRADE.
 - (2) TO BE H-20 RATED IF LID IS LESS THAN 9" ABOVE GRADE, OR IF LOCATED IN TRAFFIC AREA.
11. METER VAULT SHALL BE PROVIDED WITH AN OSHA APPROVED GALVANIZED STEEL LADDER AND ALUMINUM LADDER SAFETY EXTENSION. ATTACH TO VAULT WITH STAINLESS STEEL BOLTS.
12. CONTRACTOR TO INSTALL SUMP PUMP (5 GPM MIN) WITH 120V POWER SUPPLY, ALONG WITH PRIVATE POWER SOURCE (RESPONSIBILITY OF CONTRACTOR INSTALLING VAULT). SCHED 40 CONDUIT, WIRE, ETC. FOR SUMP PUMP POWER SHALL CONFORM WITH NEC REQUIREMENTS.
13. SUMP PUMP DISCHARGE PIPE SHALL BE 1½-INCH SCHEDULE 40 PVC, PROVIDED WITH UNION (FOR PUMP REMOVAL), CHECK VALVE AND ISOLATION BALL VALVE. CONNECT DISCHARGE TO GRAVITY STORM DRAIN OR CURB WEEP HOLE (AT LOCATION APPROVED BY PUBLIC WORKS).
14. SUMP TO BE 18" ROUND CONCRETE PIPE OR EQUAL. PROVIDE FRP GRATE (OR SLOTTED MH LID) WITH COPED CUTOUT FOR DISCHARGE PIPING (IE. LID TO BE REMOVABLE WITHOUT DISASSEMBLING DISCHARGE PIPING). SUMP TO BE LARGE ENOUGH & DEEP ENOUGH TO HOUSE PUMP & FLOAT, AND KEEP WATER LEVEL BELOW SLOPED FLOOR.

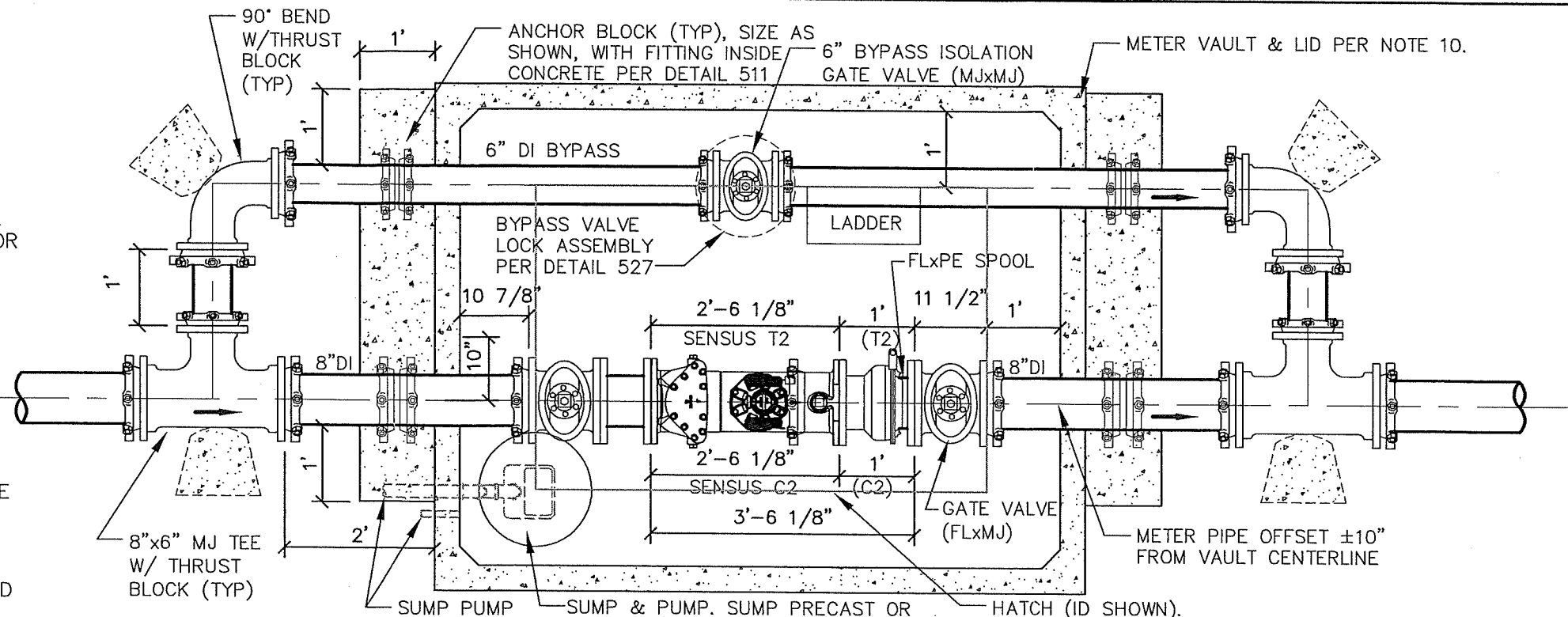

SET TOP AT FINISH GRADE IN PAVED AREAS, SLOPE SURFACE AWAY FROM VAULT

PLAN
NTS

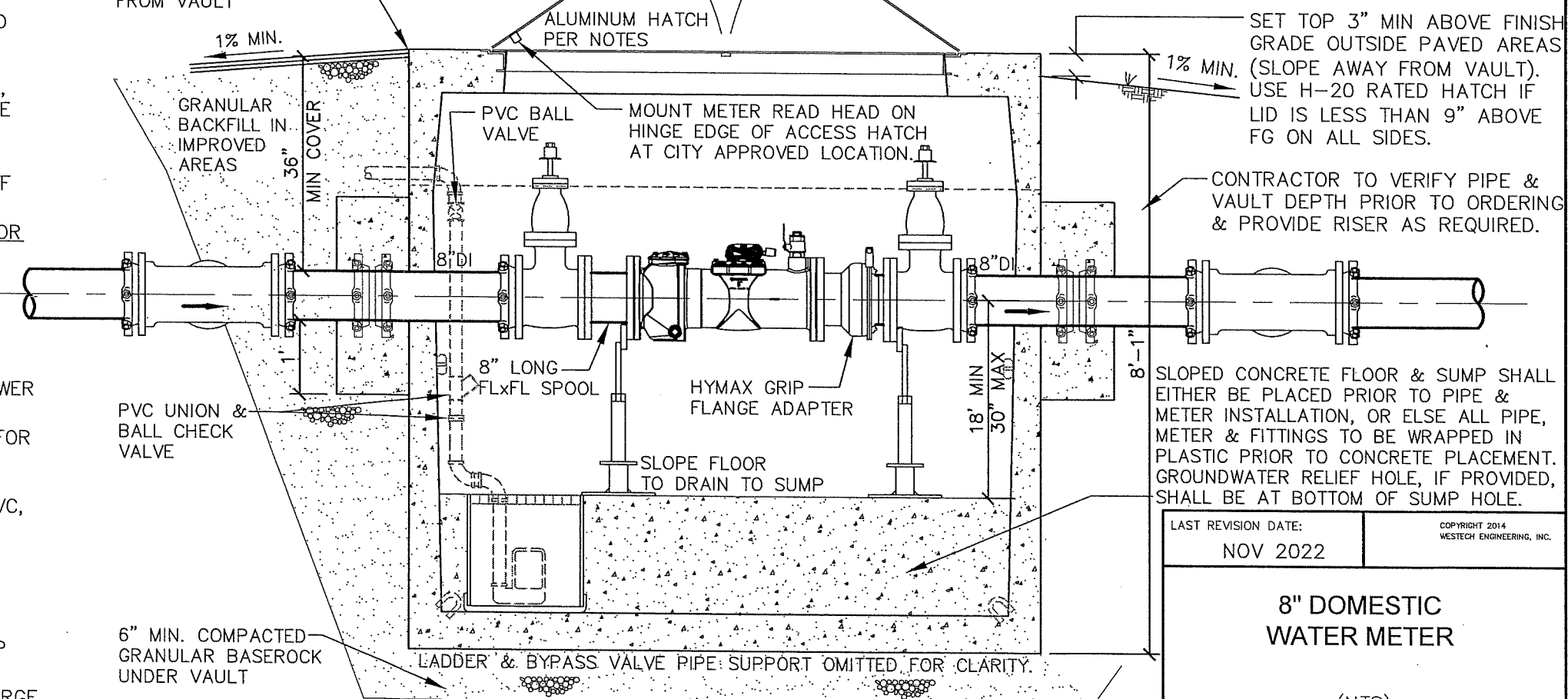

SECTION
NTS

SET TOP 3" MIN ABOVE FINISH GRADE OUTSIDE PAVED AREAS (SLOPE AWAY FROM VAULT). USE H-20 RATED HATCH IF LID IS LESS THAN 9" ABOVE FG ON ALL SIDES.

CONTRACTOR TO VERIFY PIPE & VAULT DEPTH PRIOR TO ORDERING & PROVIDE RISER AS REQUIRED.

SLOPED CONCRETE FLOOR & SUMP SHALL EITHER BE PLACED PRIOR TO PIPE & METER INSTALLATION, OR ELSE ALL PIPE, METER & FITTINGS TO BE WRAPPED IN PLASTIC PRIOR TO CONCRETE PLACEMENT. GROUNDWATER RELIEF HOLE, IF PROVIDED, SHALL BE AT BOTTOM OF SUMP HOLE.

LAST REVISION DATE: NOV 2022	COPYRIGHT 2014 WESTECH ENGINEERING, INC.
8" DOMESTIC WATER METER	
(NTS)	
AUMSVILLE, OR	DETAIL NO. 526

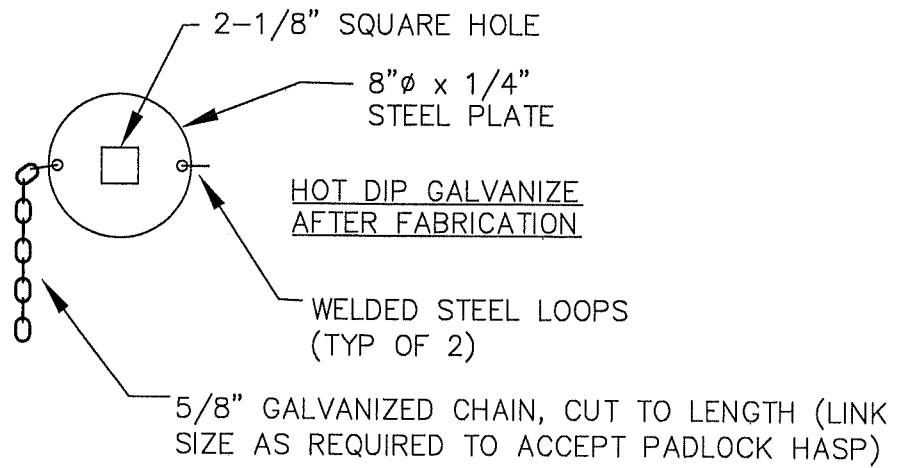

TOP VIEW

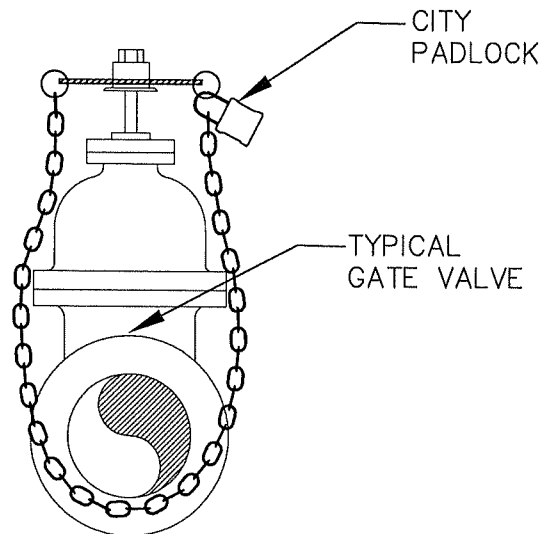

SIDE VIEW

NOTES:

1. UNLESS OTHERWISE REQUIRED BY PUBLIC WORKS, PROVIDE ONE LOCK ASSEMBLY PER VAULT.
2. VALVE LOCK ASSEMBLY TO BE HOT DIP GALVANIZED AFTER FABRICATION.

LAST REVISION DATE: FEB 2021	JO #
WATER METER VAULT BYPASS VALVE LOCK	
(NTS)	
AUMSVILLE, OR	DETAIL NO. 527

METER TEST PORT CONSISTING OF SHORT BRASS NIPPLE, BRASS BALL VALVE PROVISIONS FOR LOCKING HANDLE, & BRASS PLUG IN TOP OF BALL VALVE (SIZE TO MATCH TEST PORT ON METER).

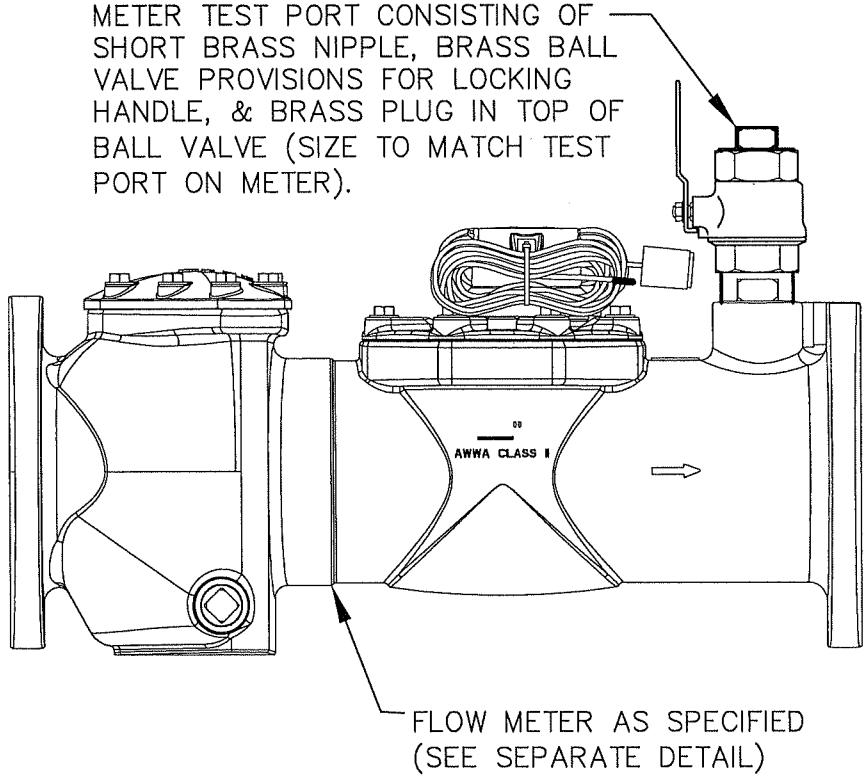

FLOW METER AS SPECIFIED (SEE SEPARATE DETAIL)

NOTES:

1. UNLESS NOTED OTHERWISE ON DRAWINGS, ALL METERS 3" & LARGER SHALL BE PROVIDED WITH A TEST PORT ASSEMBLY CONSISTING OF NIPPLE, BALL VALVE AND PLUG AS NOTED.

LAST REVISION DATE: FEB 2021	
WATER METER TEST PORT ASSEMBLY	
(NTS)	
AUMSVILLE, OR	DETAIL NO. 528

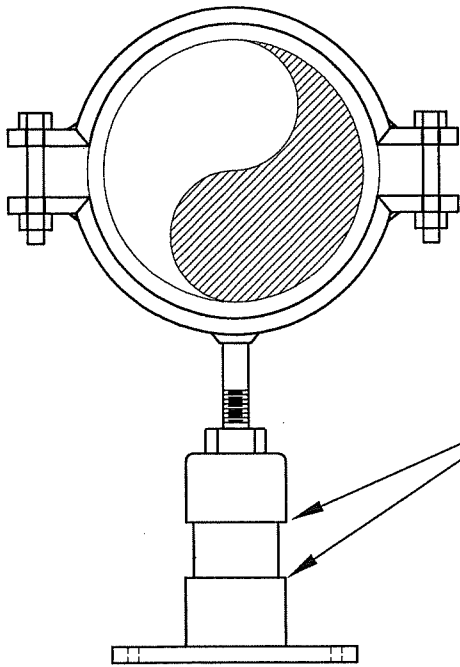

STANDON MODEL C92 ADJUSTABLE PIPE SUPPORT (GALVANIZED STEEL TOP & BASE) OR EQUAL (PROVIDE NEOPRENE LINER FOR STEEL OR PVC PIPE)

WHERE FULLY RESTAINED SUPPORTS ARE SPECIFIED OR NOTED ON THE DRAWING, FILLET TACK WELD SUPPORT PIPE TO BASE AND TOP COLLARS AFTER INSTALLATION (E70XX ELECTRODES FOR WELDS). COAT WELDS WITH HIGH ZINC PAINT (2 COATS), TYP ALL.

FULL CIRCLE CLAMP STYLE SUPPORT

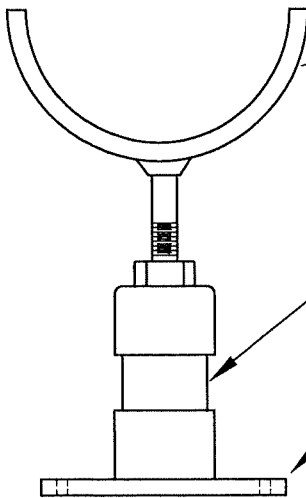

STANDON MODEL S92 ADJUSTABLE PIPE SUPPORT (GALVANIZED STEEL TOP & BASE) OR EQUAL (PROVIDE NEOPRENE LINER FOR STEEL OR PVC PIPE)

SCHEDULE 40 GALVANIZED STEEL PIPE (TYP ALL STYLES, LENGTH AS REQUIRED), DIA. PER MANUFACTURER'S RECOMMENDATIONS

INSTALL (4) EACH 1/2" X 4" STAINLESS STEEL CONCRETE ANCHORS OR STUD ANCHORS WITH NUTS (TYP ALL STYLES).

SADDLE STYLE SUPPORT

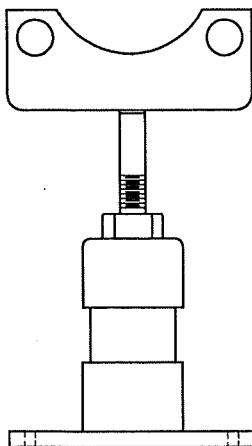

STANDON MODEL C89 ADJUSTABLE PIPE SUPPORT (GALVANIZED STEEL TOP & BASE) OR EQUAL

12" SQUARE CONCRETE PIER BLOCK FOR SUPPORT IN AREAS WITHOUT SLAB OR PAVEMENT. ANCHOR BOLTS/STUDS AS NOTED ABOVE.

FLANGE STYLE SUPPORT

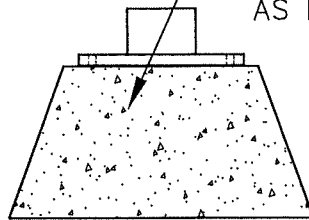

BASE IN AREA W/OUT HARD SURFACE

LAST REVISION DATE:
FEB 2021

COPYRIGHT 2018
WESTECH ENGINEERING, INC.

**GALVANIZED PIPE SUPPORTS
W/GALVANIZED EXT. PIPE
(FLANGE, SADDLE & CLAMP)
(NTS)**

AUMSVILLE, OR

DETAIL NO.
529

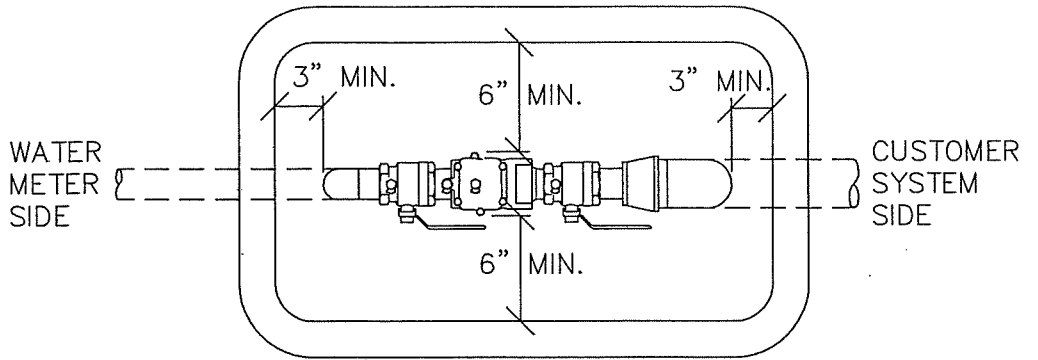

PLAN

PLASTIC OR POLYMER CONCRETE BOX, SIZE & DEPTH AS REQUIRED FOR CLEARANCES LISTED.

3/4"-2" FEBCO MODEL 850 DOUBLE CHECK ASSEMBLY (OR EQUAL) (SEE PLANS FOR SPECIFIED SIZE)

INCREASER ALLOWED ON DOWN STREAM SIDE (OPTIONAL)

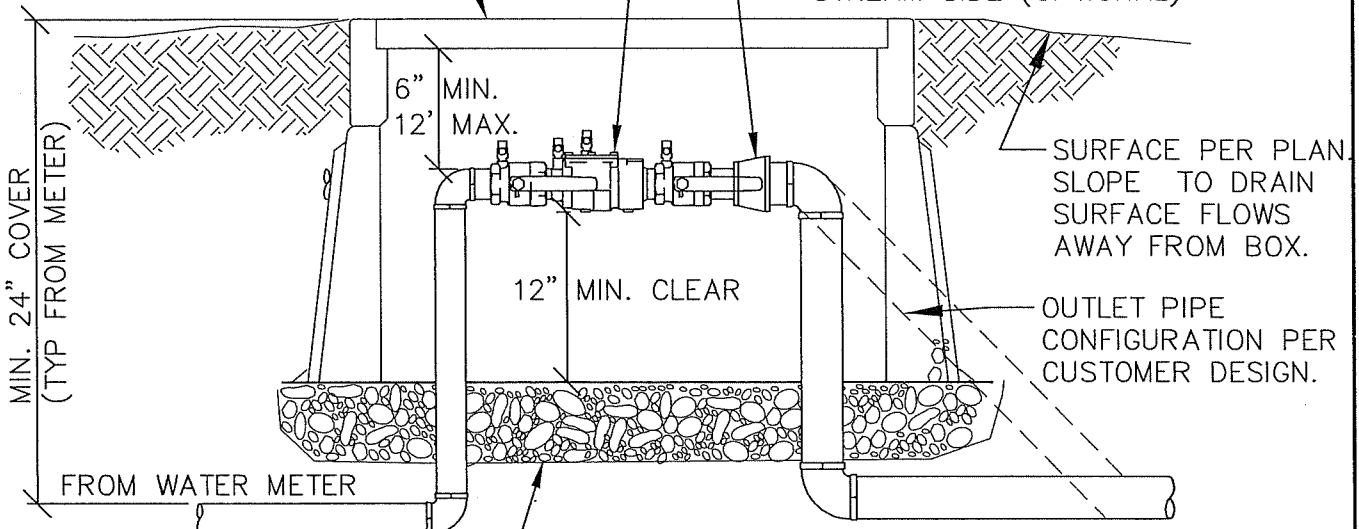

ELEVATION

MIN. 6" THICK PEA ROCK OR CLEAN GRANULAR ROCK UNDER BOX FOOTPRINT.

TO CUSTOMER SYSTEM (DEPTH PER CUSTOMER DESIGN)

USE OF PURPLE PVC PRIMER ON ALL PVC SOLVENT CEMENT JOINTS IS MANDATORY (SEE ALSO OPSC 605.12.2).

NOTES:

1. VERIFY THE ENCLOSURE/BOX DIMENSIONS & DEPTH ARE ADEQUATE FOR CLEARANCES SHOWN, BASED ON THE SIZE OF THE DCA AND FITTINGS ACTUALLY PROVIDED & INSTALLED.
2. ENCLOSURE/BOX SHALL BE CENTERED OVER THE COMPLETED DOUBLE CHECK ASSEMBLY.
3. PER OAR 333-61-0071, DCA SHALL NOT BE SUBJECT TO CONTINUOUS IMMERSION.
4. DCA's SHALL BE INSTALLED ABOVE THE 100 YEAR FLOOD LEVEL UNLESS OTHERWISE APPROVED IN WRITING BY THE PUBLIC WORKS DIRECTOR.
5. BYPASS LINES AROUND DOUBLE CHECK ASSEMBLIES ARE NOT ALLOWED.
6. DCA's SHALL BE PROVIDED WITH BRASS OR PLASTIC PLUGS IN ALL TEST PORTS.
7. DCA SHALL BE LOCATED ON PRIVATE PROPERTY, AND SHALL NOT BE INSTALLED IN SIDEWALKS OR AREAS SUBJECT TO VEHICULAR TRAFFIC.
8. THE PROPERTY OWNER IS RESPONSIBLE TO MAINTAIN A MINIMUM OF 3 FEET OF MAINTENANCE ACCESS WORKING CLEARANCE AROUND DCA ENCLOSURES/BOXES.
9. PRIOR TO REQUESTING APPROVAL OR FINAL INSPECTION BY THE CITY, CONTRACTOR SHALL HAVE DCA TESTED, AND COPIES OF TEST REPORTS PROVIDED TO PUBLIC WORKS.
10. PROPERTY OWNER SHALL BE RESPONSIBLE TO PROVIDE FREEZE PROTECTION DURING COLD WEATHER PERIODS AS NECESSARY.

LAST REVISION DATE: AUG 2022	JO # STANDARD
2" AND SMALLER DOUBLE CHECK VALVE ASSEMBLY (DCA) (NTS)	
AUMSVILLE, OR	DETAIL NO. 531

PAD MOUNTED FIBERGLASS INSULATED ENCLOSURE W/HEATER, HOT BOX MODEL AS SHOWN ON TABLE (OR APPROVED EQUIVALENT). ANCHOR ENCLOSURE TO CONCRETE PAD PER MANUFACTURER'S REQUIREMENTS.

RPBA DIAMETER	HOT BOX MODEL
1"	HB1
1½"	HB1
2"	HB1.5

NOTE: VERIFY HB SIZE FOR OTHER CONFIGURATION OR MODEL OF RPBA DEVICE, TO ENSURE 3" MIN CLEARANCE AT EACH END (OAR 333-061-0071).

ELECTRICAL RECEPTACLE FOR HEAT TAPE (GFI). PROVIDE HEAT TAPE OR ENCLOSURE HEATER FOR ALL ABOVE GRADE PIPING. MOUNT RECEPTACLE 18" ABOVE SLAB ON TOP OF RIGID CONDUIT OR ON UNI-STRUT.

REDUCED PRESSURE BACKFLOW ASSEMBLY (RPBA) MFR'D BY FEBCO, MODEL 825YA (OR APPROVED EQUAL)

DO NOT OBSTRUCT ENCLOSURE OPENINGS (TYP)

SCH 80 PVC PIPE, TYPICAL BOTH VERTICAL RISERS

4" CONCRETE PAD
SURFACE PER PLAN SLOPE TO DRAIN

WYE STRAINER
12" MIN
TYP (ALL WAYS)

3" PIPE SLEEVE
FIELD LOCATE (TYP 2)

MIN. 2" COMPACTED GRANULAR BASEROCK
COMPACTED SUBGRADE

ELECTRICAL CONDUIT & WIRE TO POWER SOURCE. COORDINATE AS REQ'D TO PROVIDE 120V POWER.

SCHEDULE 40 PVC FROM WATER SERVICE, SIZE AS SHOWN ON PLANS

USE OF PURPLE PVC PRIMER ON ALL PVC SOLVENT CEMENT JOINTS IS MANDATORY (SEE ALSO OPSC 605.12.2).

SCHEDULE 40 PVC TO BUILDING. SIZE AS SHOWN ON PLANS

NOTES:

1. RPBA- REDUCED PRESSURE BACKFLOW ASSEMBLY.
2. INSTALLATION OF RPBA & ENCLOSURE SHALL MEET OREGON HEALTH AUTHORITY, DRINKING WATER SERVICES REQUIREMENTS.
3. CONTRACTOR SHALL HAVE RPBA TESTED AND CERTIFIED PRIOR TO APPROVAL BY THE CITY, AND COPIES OF TEST REPORTS PROVIDED TO CITY.
4. RPBA & ENCLOSURE SHALL CONFORM TO REQUIREMENTS OF PUBLIC/PRIVATE AGENCIES HAVING JURISDICTION.
5. ENCLOSURES SHALL HAVE A MINIMUM OF 3' CLEARANCE FROM ALL OTHER VAULTS OR STRUCTURES.
6. VERIFY ENCLOSURE DIMENSIONS ARE ADEQUATE FOR CLEARANCE BASED ON HEIGHT OF REDUCED PRESSURE ASSEMBLY.
7. ENCLOSURE SHALL BE CENTERED OVER THE COMPLETED REDUCED PRESSURE BACKFLOW ASSEMBLY.
8. POWER SHALL BE INSTALLED IN SCHEDULE 40 RIGID CONDUIT PER NEC REQUIREMENTS.
9. ALL CONCRETE SHALL BE 3,300 PSI @ 28 DAYS, MAX 5" SLUMP, 4.5% AIR (±1.5%).
10. HOT BOX DRAINAGE OPENINGS SHALL NOT BE OBSTRUCTED BY GRADING OR PLANTINGS.
11. RPBA SHALL BE INSTALLED A MIN. OF 12 INCHES ABOVE THE 100-YEAR FLOOD ELEVATION AS DETERMINED BY FEMA.
12. FINISH GRADE TO SLOPE AWAY FROM ENCLOSURE SLAB AT 2% MIN. SLOPE.
13. AFTER CONSTRUCTION COMPLETION & ACCEPTANCE, PROPERTY OWNER IS RESPONSIBLE TO ENSURE FREEZE PROTECTION IS PLUGGED IN & WORKING DURING COLD WEATHER PERIODS AS NECESSARY.

LAST REVISION DATE: DEC 2022	JO # STANDARD
2" AND SMALLER REDUCED PRESSURE BACKFLOW ASSEMBLY (NTS)	
AUMSVILLE, OR	DETAIL NO. 541

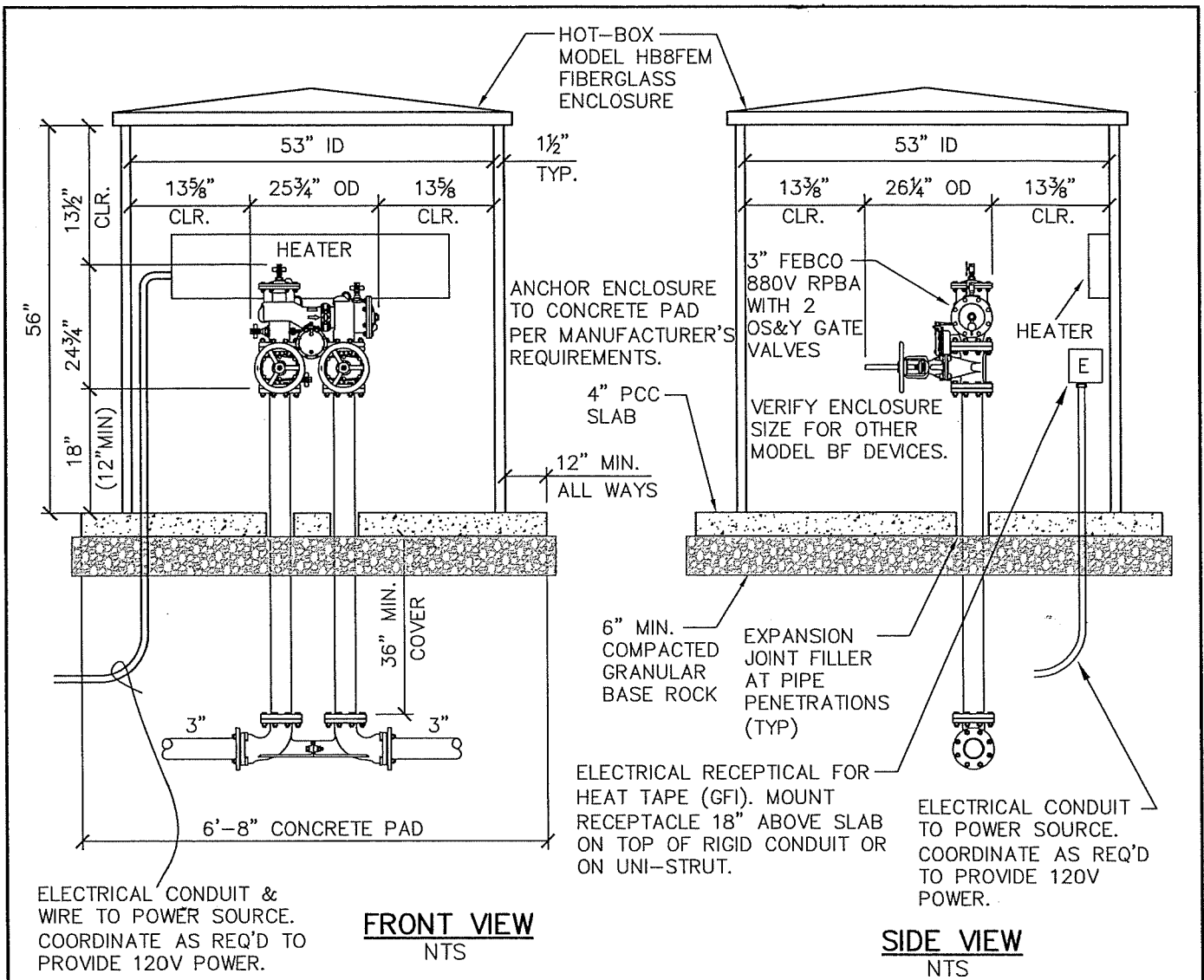

ELECTRICAL CONDUIT & WIRE TO POWER SOURCE. COORDINATE AS REQ'D TO PROVIDE 120V POWER.

FRONT VIEW
NTS

ELECTRICAL RECEPTACLE FOR HEAT TAPE (GFI). MOUNT RECEPTACLE 18" ABOVE SLAB ON TOP OF RIGID CONDUIT OR ON UNI-STRUT.

ELECTRICAL CONDUIT TO POWER SOURCE. COORDINATE AS REQ'D TO PROVIDE 120V POWER.

SIDE VIEW
NTS

NOTES:

1. RPBA- REDUCED PRESSURE BACKFLOW ASSEMBLY.
2. INSTALLATION OF RPBA & ENCLOSURE SHALL MEET OREGON HEALTH AUTHORITY, DRINKING WATER SERVICES REQUIREMENTS.
3. CONTRACTOR SHALL HAVE RPBA TESTED AND CERTIFIED PRIOR TO APPROVAL BY THE CITY, AND COPIES OF TEST REPORTS PROVIDED TO CITY.
4. RPBA & ENCLOSURE SHALL CONFORM TO REQUIREMENTS OF PUBLIC/PRIVATE AGENCIES HAVING JURISDICTION.
5. ENCLOSURES SHALL HAVE A MINIMUM OF 3' CLEARANCE FROM ALL OTHER VAULTS OR STRUCTURES.
6. VERIFY ENCLOSURE DIMENSIONS ARE ADEQUATE FOR CLEARANCE BASED ON HEIGHT OF REDUCED PRESSURE ASSEMBLY.
7. ENCLOSURE SHALL BE CENTERED OVER THE COMPLETED REDUCED PRESSURE BACKFLOW ASSEMBLY.
8. POWER SHALL BE INSTALLED IN SCHEDULE 40 RIGID CONDUIT PER NEC REQUIREMENTS.
9. ALL CONCRETE SHALL BE 3,300 PSI @ 28 DAYS, MAX 5" SLUMP, 4.5% AIR (±1.5%).
10. HOT BOX DRAINAGE OPENINGS SHALL NOT BE OBSTRUCTED BY GRADING OR PLANTINGS.
11. RPBA SHALL BE INSTALLED A MIN. OF 12 INCHES ABOVE THE 100-YEAR FLOOD ELEVATION AS DETERMINED BY FEMA.
12. FINISH GRADE TO SLOPE AWAY FROM ENCLOSURE SLAB AT 2% MIN. SLOPE.
13. RISER PIPES & ABOVE GRADE PIPING SHALL BE DUCTILE IRON (CL 52 MIN).

LAST REVISION DATE: SEPT 2021	JO #
3" REDUCED PRESSURE ASSEMBLY	
(NTS)	
AUMSVILLE, OR	DETAIL NO. 543

MODEL NO. HB4E AS
 MANUFACTURED BY HOT BOX
 (1-800-736-0238)
 ANCHOR ENCLOSURE
 TO CONCRETE PAD
 PER MANUFACTURER'S
 REQUIREMENTS.

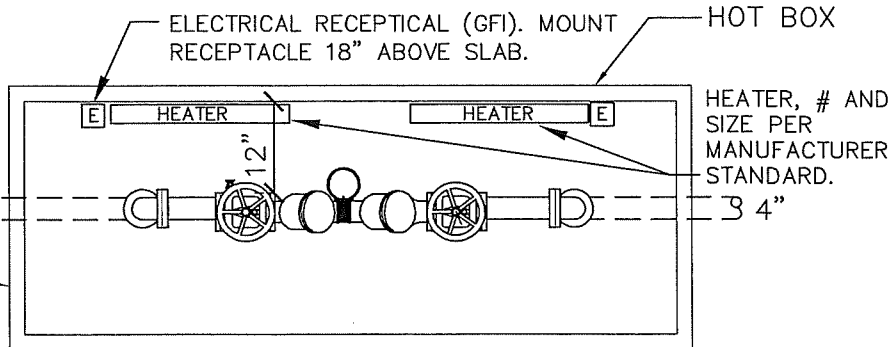

NOTE: VERIFY ENCLOSURE SIZE
 FOR ACTUAL PROVIDED BF DEVICE.

ACCESS OPENING
 (CENTERED ON RP ASSY)

PLAN
 NTS

4" FEBCO 860 REDUCED
 PRESSURE ASSEMBLY (OR
 APPROVED EQUAL) WITH 2
 OS&Y GATE VALVES (TYP)

90° VERT MJ BEND
 W/MEGALUGS
 (TYP EACH SIDE)

STANDON MODEL S89
 FLANGE SUPPORT OR
 APPROVED EQUAL (TYP).

6" MIN. COMPACTED
 GRANULAR BASEROCK

PROVIDE EXPANSION
 JOINT FILLER AT PIPE
 PENETRATIONS (TYP)

ELECTRICAL CONDUIT &
 WIRE TO POWER SOURCE.
 COORDINATE AS REQ'D TO
 PROVIDE 120V POWER.

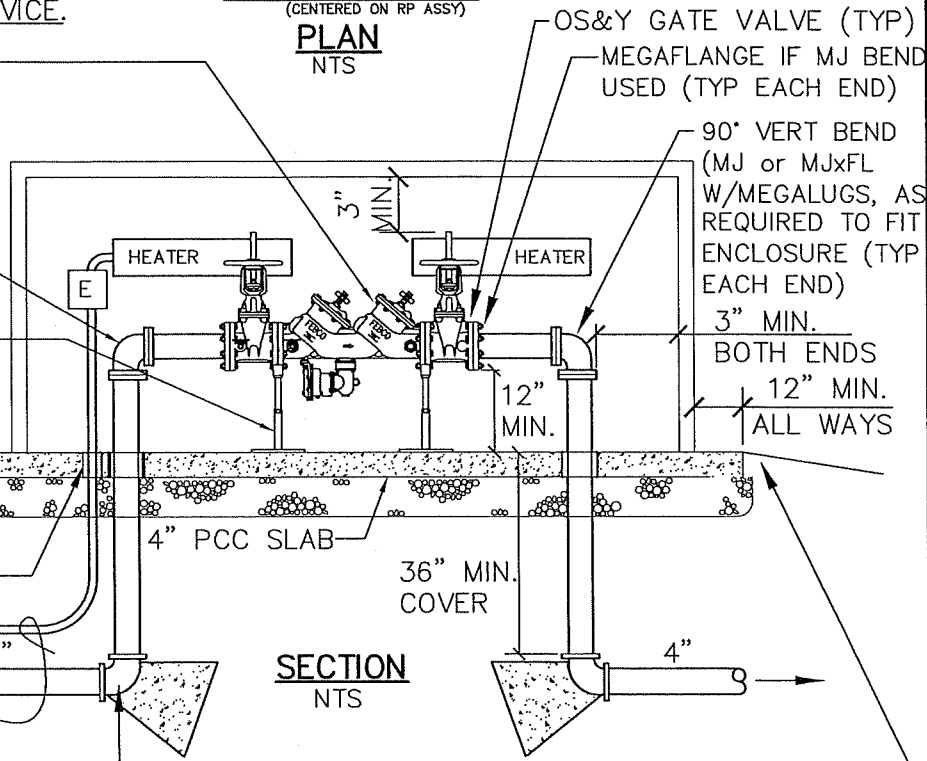

SECTION
 NTS

90° VERT MJ BEND
 W/THRUST BLOCK
 (TYP EACH SIDE)

FINISH GRADE TO SLOPE
 AWAY FROM VAULT AT
 MIN. SLOPE = 2%

NOTES:

1. RPA- REDUCED PRESSURE ASSEMBLY
2. INSTALLATION OF RPA & ENCLOSURE SHALL MEET OREGON HEALTH AUTHORITY, DRINKING WATER SERVICES REQUIREMENTS.
3. CONTRACTOR SHALL HAVE RPA TESTED AND CERTIFIED PRIOR TO APPROVAL BY THE CITY, AND COPIES OF TEST REPORTS PROVIDED TO CITY.
4. RPA & ENCLOSURE SHALL CONFORM TO REQUIREMENTS OF PUBLIC/PRIVATE AGENCIES HAVING JURISDICTION.
5. ENCLOSURE SHALL HAVE A MINIMUM OF 3' CLEARANCE FROM ALL OTHER VAULTS OR STRUCTURES.
6. VERIFY ENCLOSURE DIMENSIONS ARE ADEQUATE FOR CLEARANCE BASED ON DIMENSIONS OF REDUCED PRESSURE ASSEMBLY PROVIDED.
7. ENCLOSURE SHALL BE CENTERED OVER THE COMPLETED REDUCED PRESSURE ASSEMBLY (LENGTH-WISE).
8. POWER SHALL BE INSTALLED IN SCHEDULE 40 RIGID CONDUIT PER NEC REQUIREMENTS.
9. 'E' INDICATES THE ELECTRICAL RECEPTACLE. IT SHALL BE MOUNTED A MIN. OF 18" ABOVE THE SLAB.
10. ALL CONCRETE SHALL BE 3,300 PSI @ 28 DAYS, MAX 5" SLUMP, 4.5% AIR (±1.5%).
11. HOT BOX DRAINAGE OPENINGS SHALL NOT BE OBSTRUCTED BY GRADING OR PLANTINGS.
12. RPA SHALL BE INSTALLED A MIN. OF 12 INCHES ABOVE THE 100-YEAR FLOOD ELEVATION AS DETERMINED BY FEMA.
13. RISER PIPES & ABOVE GRADE PIPING SHALL BE DUCTILE IRON (CL 52 MIN).

LAST REVISION DATE: SEPT 2021	JO # STANDARD
4" REDUCED PRESSURE ASSEMBLY	
(NTS)	
AUMSVILLE, OR	DETAIL NO. 544

MODEL NO. HB4E AS MANUFACTURED BY HOT BOX (1-800-736-0238) ANCHOR ENCLOSURE TO CONCRETE PAD PER MANUFACTURER'S REQUIREMENTS.

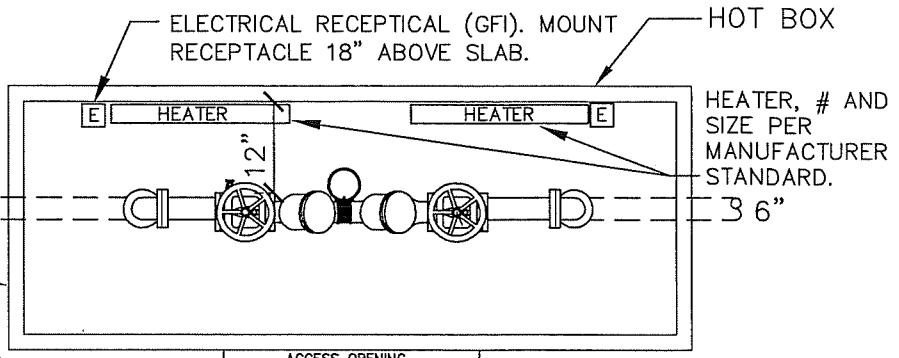

NOTE: VERIFY ENCLOSURE SIZE FOR ACTUAL PROVIDED BF DEVICE.

ACCESS OPENING (CENTERED ON RP ASSY)

PLAN
NTS

6" FEBCO 860 REDUCED PRESSURE ASSEMBLY WITH 2 OS&Y GATE VALVES (TYP)

90° VERT MJ BEND W/MEGALUGS (TYP EACH SIDE)

STANDON MODEL S89 FLANGE SUPPORT OR APPROVED EQUAL (TYP).

6" MIN. COMPACTED GRANULAR BASEROCK

PROVIDE EXPANSION JOINT FILLER AT PIPE PENETRATIONS (TYP)

ELECTRICAL CONDUIT & WIRE TO POWER SOURCE. COORDINATE AS REQ'D TO PROVIDE 120V POWER.

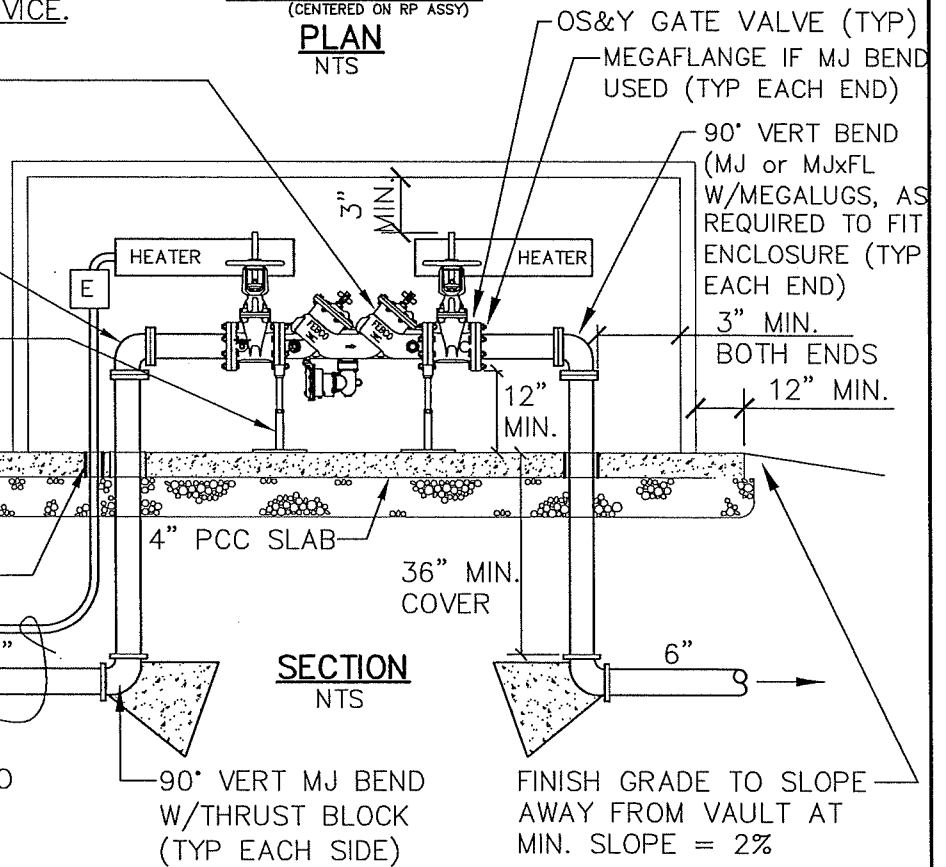

SECTION
NTS

FINISH GRADE TO SLOPE AWAY FROM VAULT AT MIN. SLOPE = 2%

NOTES:

1. RPA- REDUCED PRESSURE ASSEMBLY
2. INSTALLATION OF RPA & ENCLOSURE SHALL MEET OREGON HEALTH AUTHORITY, DRINKING WATER SERVICES REQUIREMENTS.
3. CONTRACTOR SHALL HAVE RPA TESTED AND CERTIFIED PRIOR TO APPROVAL BY THE CITY, AND COPIES OF TEST REPORTS PROVIDED TO CITY.
4. RPA & ENCLOSURE SHALL CONFORM TO REQUIREMENTS OF PUBLIC/PRIVATE AGENCIES HAVING JURISDICTION.
5. ENCLOSURE SHALL HAVE A MINIMUM OF 3' CLEARANCE FROM ALL OTHER VAULTS OR STRUCTURES.
6. VERIFY ENCLOSURE DIMENSIONS ARE ADEQUATE FOR CLEARANCE BASED ON DIMENSIONS OF REDUCED PRESSURE ASSEMBLY PROVIDED.
7. ENCLOSURE SHALL BE CENTERED OVER THE COMPLETED REDUCED PRESSURE ASSEMBLY (LENGTH-WISE).
8. POWER SHALL BE INSTALLED IN SCHEDULE 40 RIGID CONDUIT PER NEC REQUIREMENTS.
9. 'E' INDICATES THE ELECTRICAL RECEPTACLE. IT SHALL BE MOUNTED A MIN. OF 18" ABOVE THE SLAB.
10. ALL CONCRETE SHALL BE 3,300 PSI @ 28 DAYS, MAX 5" SLUMP, 4.5% AIR (±1.5%).
11. HOT BOX DRAINAGE OPENINGS SHALL NOT BE OBSTRUCTED BY GRADING OR PLANTINGS.
12. RPA SHALL BE INSTALLED A MIN. OF 12 INCHES ABOVE THE 100-YEAR FLOOD ELEVATION AS DETERMINED BY FEMA.
13. RISER PIPES & ABOVE GRADE PIPING SHALL BE DUCTILE IRON (CL 52 MIN).

LAST REVISION DATE: SEPT 2021	JO # STANDARD
6" REDUCED PRESSURE ASSEMBLY	
(NTS)	
AUMSVILLE, OR	DETAIL NO. 545

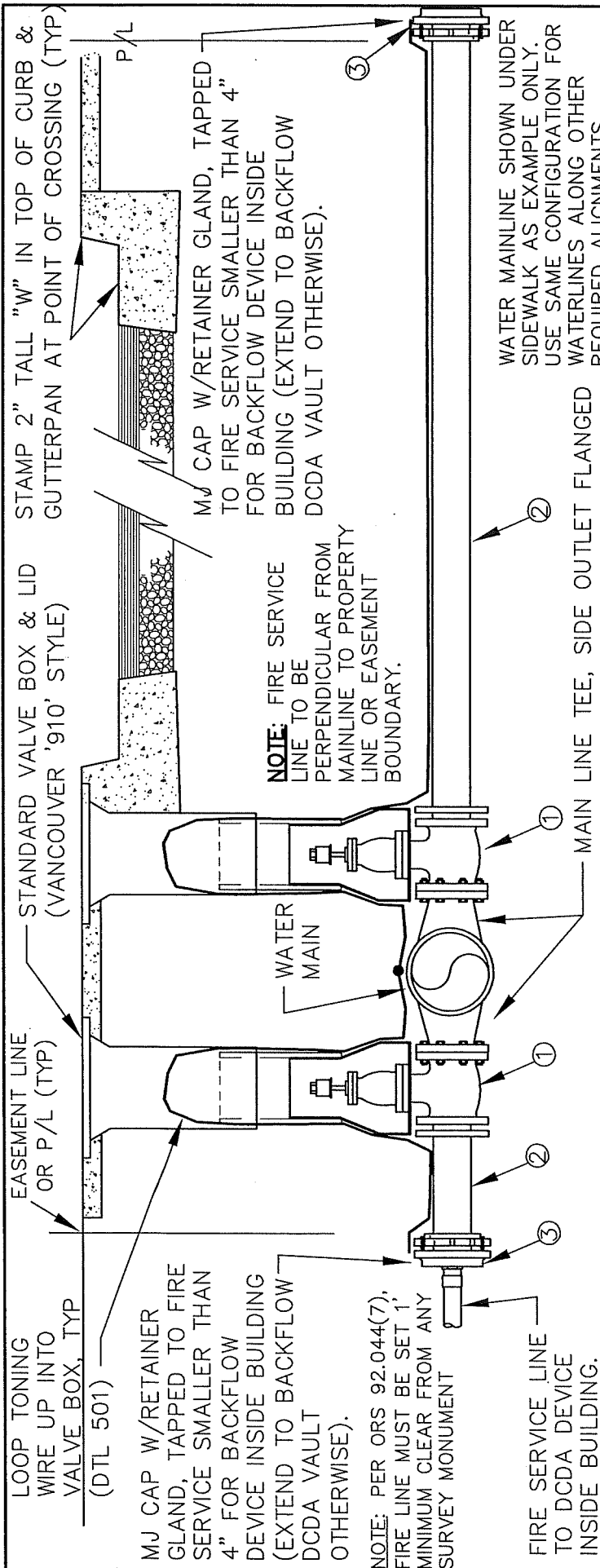

WATER MAINLINE SHOWN UNDER SIDEWALK AS EXAMPLE ONLY. USE SAME CONFIGURATION FOR WATERLINES ALONG OTHER REQUIRED ALIGNMENTS.

NOTE: FIRE SERVICE LINE TO BE PERPENDICULAR FROM MAINLINE TO PROPERTY LINE OR EASEMENT BOUNDARY.

NOTE: PER ORS 92.044(7), FIRE LINE MUST BE SET 1' MINIMUM CLEAR FROM ANY SURVEY MONUMENT

NOTE: FIRE SERVICE LINE TO BE PERPENDICULAR FROM MAINLINE TO PROPERTY LINE OR EASEMENT BOUNDARY.

NOTE: FIRE SERVICE LINE TO BE PERPENDICULAR FROM MAINLINE TO PROPERTY LINE OR EASEMENT BOUNDARY.

MATERIALS

- ① FLG X MJ RESILIENT WEDGE GATE VALVE (PER AWWA C-509), 4" DIA. MINIMUM OR FIRE SERVICE SIZE, WHICHEVER IS LARGER. VALVE TO BE EPOXY COATED PER AWWA C-550. PROVIDE APPROVED RETAINER GLAND ON MJ JOINT.
- ② CLASS 52 DUCTILE IRON PIPE REQUIRED WITHIN RIGHT-OF-WAY OR EASEMENT BOUNDARY OR TO DCDA VAULT (WHERE DCDA NOT INSTALLED IN BUILDING), TYP. 4" DIA OR FIRE SERVICE SIZE, WHICHEVER IS LARGER. FIELD-LOK STYLE GASKETS REQUIRED ON ALL PUSH-ON JOINTS BETWEEN MAINLINE VALVE AND DCDA VAULT.
- ③ CONTRACTOR SHALL INSTALL TEMPORARY BLOWOFF TO PROVIDE FOR BLOWOFF, PRESSURE TESTING, DISINFECTION & BACTERIOLOGICAL TESTING PER CITY STANDARDS.

NOTES

- 1. SUBSTITUTES FOR ANY MATERIAL SHOWN SHALL BE APPROVED BY THE CITY ENGINEER.
- 2. ALL PIPE AND BACKFILL ZONES SHALL BE BACKFILLED USING 3/4" MINUS GRANULAR MATERIAL AND COMPACTED TO 92% MAX DENSITY AS DETERMINED BY ASHTO T-180.
- 3. FIRE SERVICE LINE BEYOND PROPERTY OR EASEMENT LINE (TO BACKFLOW DEVICE) TO BE NFPA & NSF 61 APPROVED.
- 4. CUSTOMER SHALL INSTALL AN APPROVED BACKFLOW PREVENTION DEVICE ON PRIVATE PROPERTY AT A LOCATION APPROVED BY PUBLIC WORKS.

LAST REVISION DATE: MAY 2023		COPYRIGHT WESTECH ENGINEERING, INC.	
FIRE SERVICE LINE CONNECTION REQUIREMENTS (1-1/2" AND LARGER SERVICE)			
(NTS)			
AUMSVILLE, OR		DETAIL NO. 550	

4" FEBCO 856 DOUBLE CHECK DETECTOR ASSEMBLY WITH 2 OS&Y GATE VALVES, OR APPROVED EQUAL, W/CITY APPR'D METER ON DETECTOR LOOP (ALSO SEE NOTE 13).

36" WIDE CAST-IN-PLACE CONCRETE THRUST COLLAR WITH RETAINER GLAND CENTERED IN CONCRETE (TYPICAL BOTH ENDS)

PROVIDE BALL DRIP DRAIN VALVE TO DRAIN FDC, EITHER ON CHECK VALVE OR WITH HORIZONTAL TAPPING SADDLE

INSTALL "FORWARD FLOW TEST PORT" PER DTL 559 UNLESS ALT. LOCATION APPROVED.

UTILITY VAULT 676-WA (5'6" x 7'0" ID) W/H-20 RATED LID, OR EQUIVALENT. CONTRACTOR TO VERIFY ALL DIMENSIONS PRIOR TO ORDERING & PROVIDE RISER IF REQUIRED.

POWER CONDUIT FOR SUMP PUMP & CONTROL CONDUIT TO CONNECT OS&Y VALVE TAMPER SWITCHES TO FIRE ALARM CONTROL UNIT.

F.D.C. PER FIRE DEPT. REQUIREMENTS, LOCATE AS SHOWN ON PLANS.

CONTRACTOR TO PROVIDE FDC SIGNS PER OFC 912. LOCATION PER FIRE CHIEF.

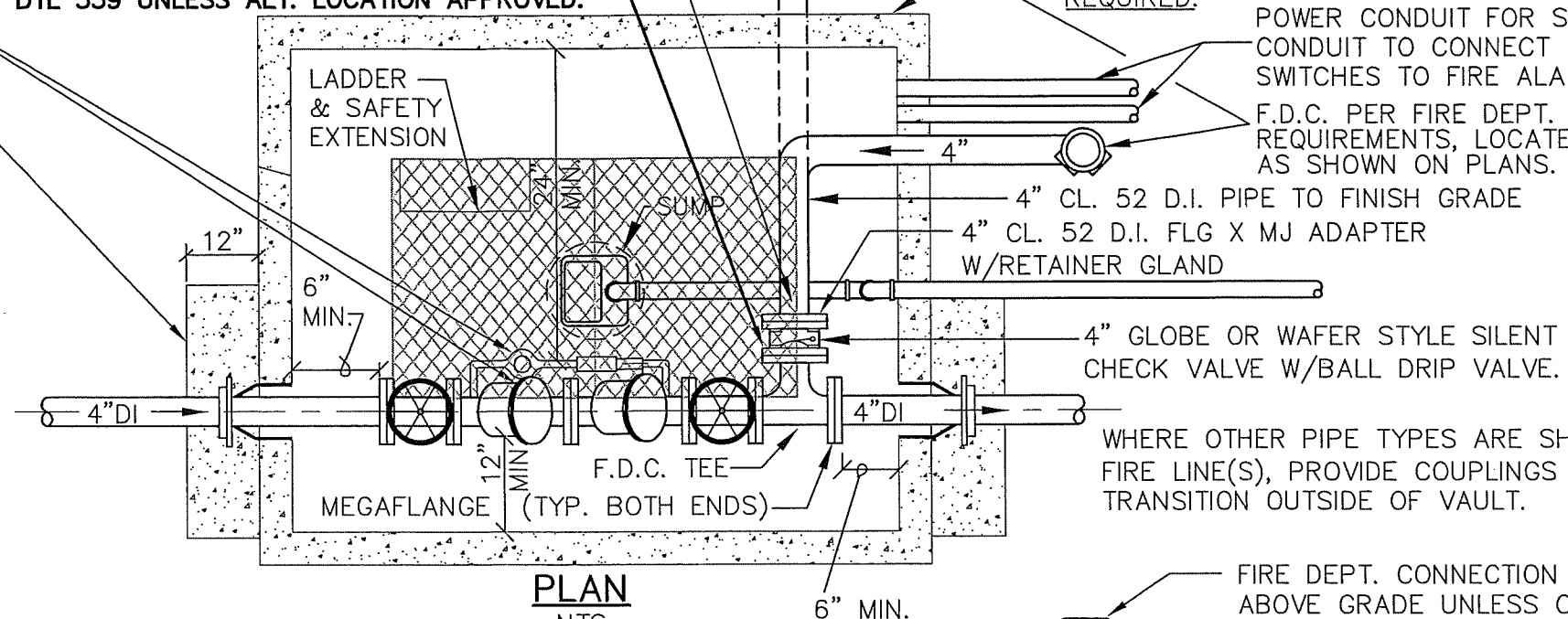

PLAN NTS

ALUMINUM HATCH (SEE NOTE 14)
 SET TOP 1" MIN. ABOVE FG. OUTSIDE PAVED AREAS. USE H-20 RATED HATCH IF LID IS LESS THAN 9" ABOVE FG ON ALL SIDES.
 SET TOP AT FINISH GRADE IN PAVED AREAS

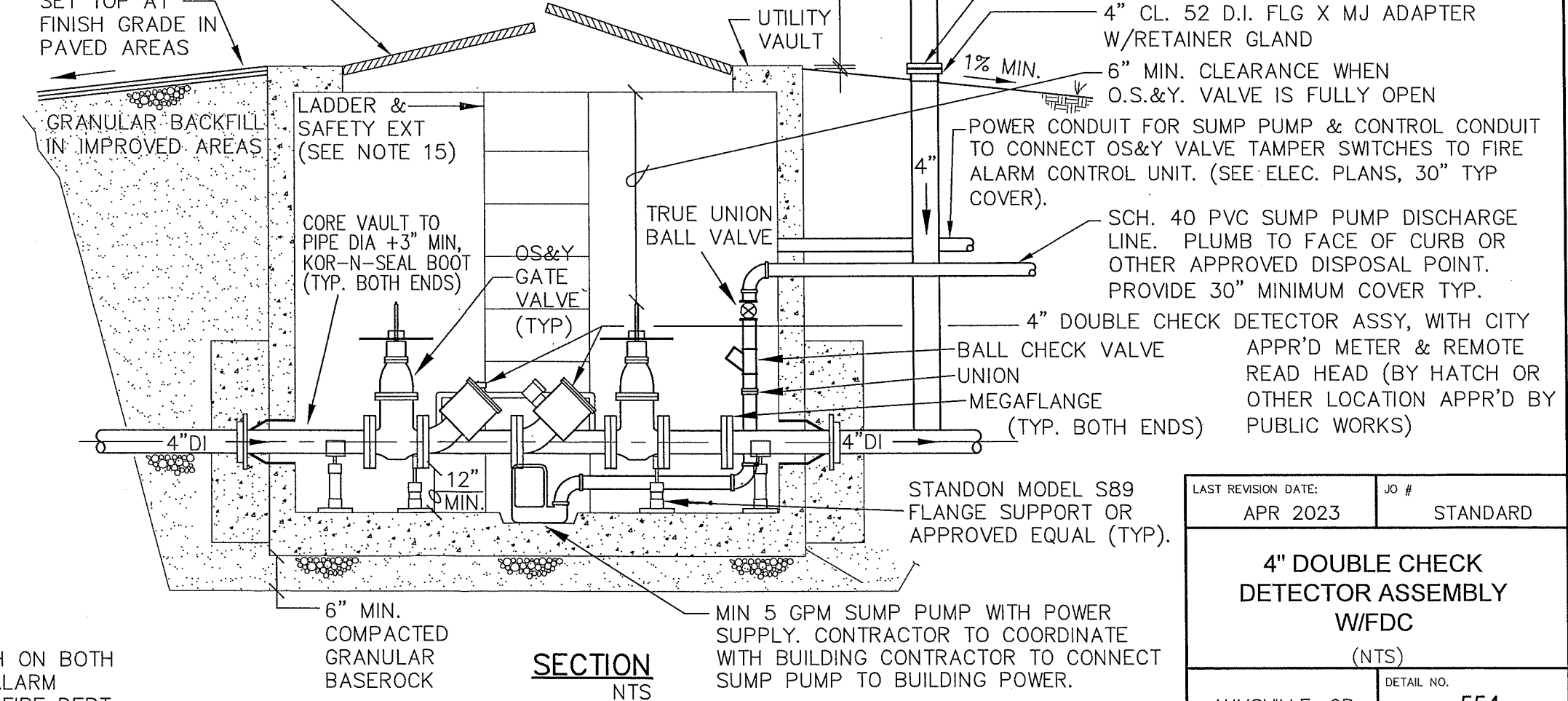

SECTION NTS

FIRE DEPT. CONNECTION SET MIN. 36" ABOVE GRADE UNLESS OTHERWISE REQUIRED BY FIRE DEPT.

4" SCH, 80 GALV. STEEL NIPPLE
 4" GALV. CI or GALV. STEEL COMPANION FLANGE
 4" CL. 52 D.I. FLG X MJ ADAPTER W/RETAINER GLAND
 6" MIN. CLEARANCE WHEN O.S.&Y. VALVE IS FULLY OPEN

POWER CONDUIT FOR SUMP PUMP & CONTROL CONDUIT TO CONNECT OS&Y VALVE TAMPER SWITCHES TO FIRE ALARM CONTROL UNIT. (SEE ELEC. PLANS, 30" TYP COVER).
 SCH. 40 PVC SUMP PUMP DISCHARGE LINE. PLUMB TO FACE OF CURB OR OTHER APPROVED DISPOSAL POINT. PROVIDE 30" MINIMUM COVER TYP.

4" DOUBLE CHECK DETECTOR ASSY, WITH CITY APPR'D METER & REMOTE READ HEAD (BY HATCH OR OTHER LOCATION APPR'D BY PUBLIC WORKS)
 BALL CHECK VALVE
 UNION
 MEGAFLANGE (TYP. BOTH ENDS)

STANDON MODEL S89 FLANGE SUPPORT OR APPROVED EQUAL (TYP.)

MIN 5 GPM SUMP PUMP WITH POWER SUPPLY. CONTRACTOR TO COORDINATE WITH BUILDING CONTRACTOR TO CONNECT SUMP PUMP TO BUILDING POWER.

NOTES:

- DCDA- DOUBLE CHECK DETECTOR ASSEMBLY FDC-FIRE DEPARTMENT CONNECTION.
- DCDA SHALL CONFORM TO REQUIREMENTS OF PUBLIC/PRIVATE AGENCIES HAVING JURISDICTION.
- DCDA & VAULT INSTALLATION SHALL MEET REQUIREMENTS OF OREGON HEALTH AUTHORITY, DRINKING WATER SERVICES (DWS).
- CONTRACTOR SHALL HAVE DCDA TESTED AND CERTIFIED PRIOR TO ACCEPTANCE BY OWNER.
- FDC SHALL NOT EXIT THROUGH THE TOP OF THE VAULT.
- ALL PIPE OPENINGS SHALL BE SEALED WITH NON-SHRINK WATERTIGHT GROUT.
- BENDS, CROSSES AND TEES SHALL NOT BE INSTALLED WITHIN 5 FEET OF THE OUTSIDE VAULT WALL.
- ALL VAULTS SHALL MEET OR EXCEED ASTM C-857. ALL VAULT CONCRETE TO BE 4500 PSI @ 28 DAYS. REBAR TO BE ASTM A-615 GRADE 60.
- SUMP PUMP WITH POWER SUPPLY SHALL BE INSTALLED UNLESS OTHERWISE APPROVED BY PUBLIC WORKS.
- SUMP PUMP DISCHARGE PIPE TO BE 1 1/2-INCH SCHED 40 PVC SHALL BE PLUMBED TO FACE OF STREET CURB OR OTHER DISPOSAL POINT APPROVED BY LOCAL JURISDICTION (SEE OAR 333-061-0071.3.f).
- CONTRACTOR TO INSTALL SUMP PUMP (5 GPM MIN) WITH 120V POWER SUPPLY, ALONG WITH PRIVATE POWER SOURCE (RESPONSIBILITY OF CONTRACTOR INSTALLING VAULT). SCHED 40 CONDUIT, WIRE, ETC. FOR SUMP PUMP POWER SHALL CONFORM WITH NEC REQUIREMENTS.
- THRUST COLLAR CONCRETE SHALL BE 3300 PSI @ 28 DAYS.
- PROVIDE REMOTE READER (RADIO READ HEAD) FOR DETECTOR LOOP METER PER LOCAL JURISDICTION REQUIREMENTS, MOUNTED ON HINGE EDGE OF HATCH.
- ALUMINUM ANGLE FRAME HATCH (3'0"x 5'6" MIN) SHALL BE BY USF FABRICATION OR APPROVED EQUAL (SAND BLASTED NON-SLIP).
 (1) TO BE 300 PSF PEDESTRIAN RATED WHERE LID IS SET MIN. OF 9" ABOVE GRADE.
 (2) TO BE H-20 RATED IF LID IS LESS THAN 9" ABOVE GRADE, OR IF LOCATED IN TRAFFIC AREA.
- OSHA APPROVED GALVANIZED STEEL LADDER & ALUMINUM LADDER SAFETY EXTENSION.
- PER OFC 903.4, INSTALL APPROVED TAMPER SWITCH ON BOTH OS&Y VALVES IN VAULT, WIRED TO A LISTED FIRE ALARM CONTROL UNIT, UNLESS EXEMPTION IS GRANTED BY FIRE DEPT.

LAST REVISION DATE: APR 2023	JO # STANDARD
4" DOUBLE CHECK DETECTOR ASSEMBLY W/FDC (NTS)	
AUMSVILLE, OR	DETAIL NO. 554

6" FEBCO 856 DOUBLE CHECK DETECTOR ASSEMBLY WITH 2 OS&Y GATE VALVES, OR APPROVED EQUAL, W/CITY APPR'D METER ON DETECTOR LOOP (ALSO SEE NOTE 13).

36" WIDE CAST-IN-PLACE CONCRETE THRUST COLLAR WITH RETAINER GLAND CENTERED IN CONCRETE (TYPICAL BOTH ENDS)

PROVIDE BALL DRIP DRAIN VALVE TO DRAIN FDC, EITHER ON CHECK VALVE OR WITH HORIZONTAL TAPPING SADDLE

UTILITY VAULT 687-WA (6'0" x 8'0" ID) W/H-20 RATED LID, OR EQUIVALENT. CONTRACTOR TO VERIFY ALL DIMENSIONS PRIOR TO ORDERING & PROVIDE RISER IF REQUIRED.

POWER CONDUIT FOR SUMP PUMP & CONTROL CONDUIT TO CONNECT OS&Y VALVE TAMPER SWITCHES TO FIRE ALARM CONTROL UNIT. F.D.C. PER FIRE DEPT. REQUIREMENTS, LOCATE AS SHOWN ON PLANS.

INSTALL "FORWARD FLOW TEST PORT" PER DTL 559 UNLESS ALT. LOCATION APPROVED.

NOTES:

1. DCDA- DOUBLE CHECK DETECTOR ASSEMBLY
- FDC-FIRE DEPARTMENT CONNECTION.
2. DCDA SHALL CONFORM TO REQUIREMENTS OF PUBLIC/PRIVATE AGENCIES HAVING JURISDICTION.
3. DCDA & VAULT INSTALLATION SHALL MEET REQUIREMENTS OF OREGON HEALTH AUTHORITY, DRINKING WATER SERVICES (DWS).
4. CONTRACTOR SHALL HAVE DCDA TESTED AND CERTIFIED PRIOR TO ACCEPTANCE BY OWNER.
5. FDC SHALL NOT EXIT THROUGH THE TOP OF THE VAULT.
6. ALL PIPE OPENINGS SHALL BE SEALED WITH NON-SHRINK WATERTIGHT GROUT.
7. BENDS, CROSSES AND TEES SHALL NOT BE INSTALLED WITHIN 5 FEET OF THE OUTSIDE VAULT WALL.
8. ALL VAULTS SHALL MEET OR EXCEED ASTM C-857. ALL VAULT CONCRETE TO BE 4500 PSI @ 28 DAYS. REBAR TO BE ASTM A-615 GRADE 60.
9. SUMP PUMP WITH POWER SUPPLY SHALL BE INSTALLED UNLESS OTHERWISE APPROVED BY PUBLIC WORKS.
10. SUMP PUMP DISCHARGE PIPE TO BE 1 1/2-INCH SCHED 40 PVC SHALL BE PLUMBED TO FACE OF STREET CURB OR OTHER DISPOSAL POINT APPROVED BY LOCAL JURISDICTION (SEE OAR 333-061-0071.3.f).
11. CONTRACTOR TO INSTALL SUMP PUMP (5 GPM MIN) WITH 120V POWER SUPPLY, ALONG WITH PRIVATE POWER SOURCE (RESPONSIBILITY OF CONTRACTOR INSTALLING VAULT). SCHED 40 CONDUIT, WIRE, ETC. FOR SUMP PUMP POWER SHALL CONFORM WITH NEC REQUIREMENTS.
12. THRUST COLLAR CONCRETE SHALL BE 3300 PSI @ 28 DAYS.
13. PROVIDE REMOTE READER (RADIO READ HEAD) FOR DETECTOR LOOP METER PER LOCAL JURISDICTION REQUIREMENTS, MOUNTED ON HINGE EDGE OF HATCH.
14. ALUMINUM ANGLE FRAME HATCH (3'0" x 5'6" MIN) SHALL BE BY USF FABRICATION OR APPROVED EQUAL (SAND BLASTED NON-SLIP).
 - (1) TO BE 300 PSF PEDESTRIAN RATED WHERE LID IS SET MIN. OF 9" ABOVE GRADE.
 - (2) TO BE H-20 RATED IF LID IS LESS THAN 9" ABOVE GRADE, OR IF LOCATED IN TRAFFIC AREA.
15. OSHA APPROVED GALVANIZED STEEL LADDER & ALUMINUM LADDER SAFETY EXTENSION.
16. PER OFC 903.4, INSTALL APPROVED TAMPER SWITCH ON BOTH OS&Y VALVES IN VAULT, WIRED TO A LISTED FIRE ALARM CONTROL UNIT, UNLESS EXEMPTION IS GRANTED BY FIRE DEPT.

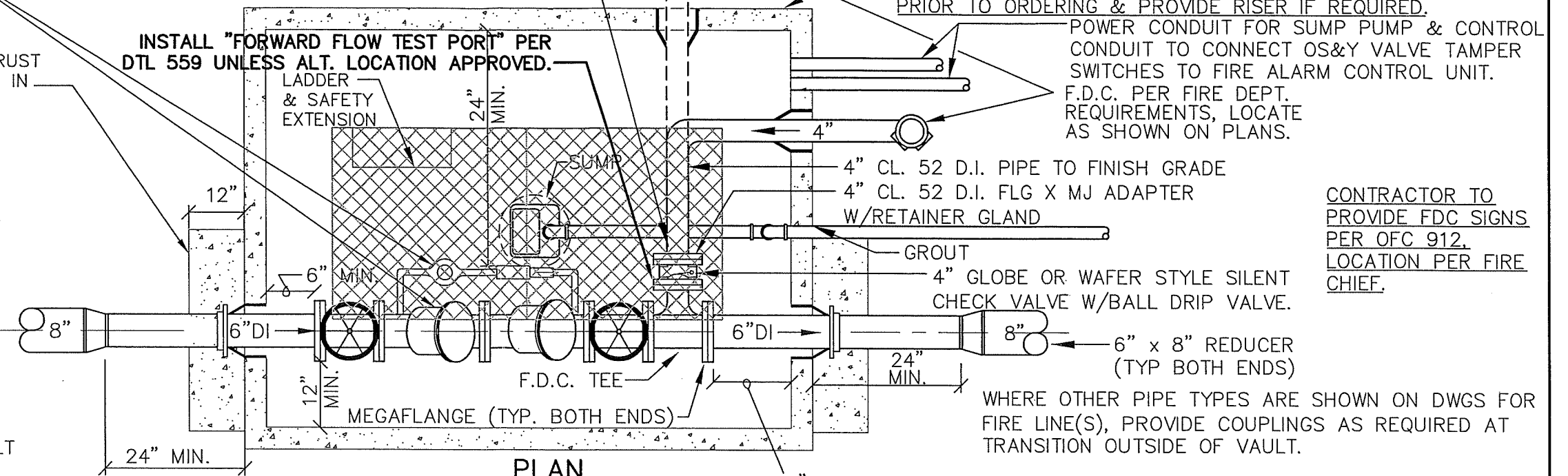

PLAN
NTS

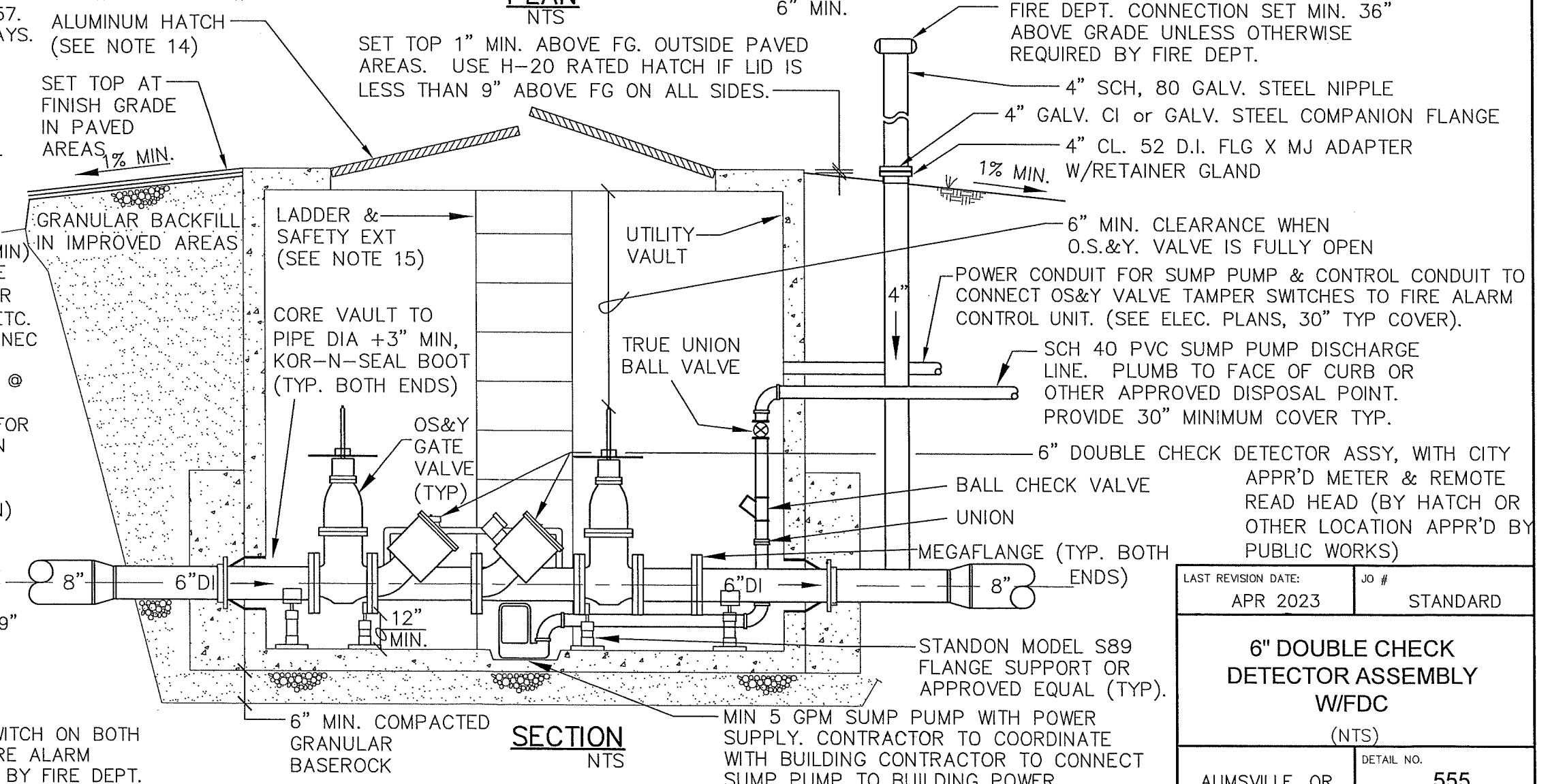

SECTION
NTS

CONTRACTOR TO PROVIDE FDC SIGNS PER OFC 912. LOCATION PER FIRE CHIEF.

WHERE OTHER PIPE TYPES ARE SHOWN ON DWGS FOR FIRE LINE(S), PROVIDE COUPLINGS AS REQUIRED AT TRANSITION OUTSIDE OF VAULT.

FIRE DEPT. CONNECTION SET MIN. 36" ABOVE GRADE UNLESS OTHERWISE REQUIRED BY FIRE DEPT.

4" SCH, 80 GALV. STEEL NIPPLE
4" GALV. CI or GALV. STEEL COMPANION FLANGE
4" CL. 52 D.I. FLG X MJ ADAPTER W/RETAINER GLAND

6" MIN. CLEARANCE WHEN O.S.&Y. VALVE IS FULLY OPEN

POWER CONDUIT FOR SUMP PUMP & CONTROL CONDUIT TO CONNECT OS&Y VALVE TAMPER SWITCHES TO FIRE ALARM CONTROL UNIT. (SEE ELEC. PLANS, 30" TYP COVER).

SCH 40 PVC SUMP PUMP DISCHARGE LINE. PLUMB TO FACE OF CURB OR OTHER APPROVED DISPOSAL POINT. PROVIDE 30" MINIMUM COVER TYP.

6" DOUBLE CHECK DETECTOR ASSY, WITH CITY APPR'D METER & REMOTE READ HEAD (BY HATCH OR OTHER LOCATION APPR'D BY PUBLIC WORKS)

LAST REVISION DATE: APR 2023	JO # STANDARD
6" DOUBLE CHECK DETECTOR ASSEMBLY W/FDC (NTS)	
AUMSVILLE, OR	DETAIL NO. 555

8" FEBCO 856 DOUBLE CHECK DETECTOR ASSEMBLY WITH 2 OS&Y GATE VALVES, OR APPROVED EQUAL, W/CITY APPR'D METER ON DETECTOR LOOP (ALSO SEE NOTE 13).

36" WIDE CAST-IN-PLACE CONCRETE THRUST COLLAR WITH RETAINER GLAND CENTERED IN CONCRETE (TYPICAL BOTH ENDS)

PROVIDE BALL DRIP DRAIN VALVE TO DRAIN FDC, EITHER ON CHECK VALVE OR WITH HORIZONTAL TAPPING SADDLE

UTILITY VAULT 5106-WA (5'0" x 10'6" ID) W/H-20 RATED LID, OR EQUIVALENT. CONTRACTOR TO VERIFY ALL DIMENSIONS PRIOR TO ORDERING & PROVIDE RISER IF REQUIRED.

POWER CONDUIT FOR SUMP PUMP & CONTROL CONDUIT TO CONNECT OS&Y VALVE TAMPER SWITCHES TO FIRE ALARM CONTROL UNIT.

F.D.C. PER FIRE DEPT. REQMNTS. LOCATE AS SHOWN ON PLANS.

CONTRACTOR TO PROVIDE FDC SIGNS PER OFC 912. LOCATION PER FIRE CHIEF.

4" CL. 52 D.I. PIPE TO FINISH GRADE
4" CL. 52 D.I. FLG X MJ ADAPTER W/RETAINER GLAND
4" GLOBE OR WAFER STYLE SILENT CHECK VALVE W/BALL DRIP VALVE.

WHERE OTHER PIPE TYPES ARE SHOWN ON DWGS FOR FIRE LINE(S), PROVIDE COUPLINGS AS REQUIRED AT TRANSITION OUTSIDE OF VAULT.

FIRE DEPT. CONNECTION SET MIN. 36" ABOVE GRADE UNLESS OTHERWISE REQUIRED BY FIRE DEPT.

4" SCH. 80 GALV. STEEL NIPPLE
4" GALV. CI or GALV. STEEL COMPANION FLANGE
4" CL. 52 D.I. FLG X MJ ADAPTER W/RETAINER GLAND

6" MIN. CLEARANCE WHEN O.S.&Y. VALVE IS FULLY OPEN

POWER CONDUIT FOR SUMP PUMP & CONTROL CONDUIT TO CONNECT OS&Y VALVE TAMPER SWITCHES TO FIRE ALARM CONTROL UNIT. (SEE ELEC. PLANS, 30" TYP COVER).
SCH 40 PVC SUMP PUMP DISCHARGE LINE. PLUMB TO FACE STREET CURB OR OTHER APPROVED DISPOSAL POINT. PROVIDE 30" MINIMUM COVER TYP.

8" DOUBLE CHECK DETECTOR ASSY, WITH CITY APPR'D METER & REMOTE READ HEAD (BY HATCH OR OTHER LOCATION APPR'D BY PUBLIC WORKS)
BALL CHECK VALVE
UNION
MEGAFLANGE (TYP. BOTH ENDS)

NOTES:

- DCDA- DOUBLE CHECK DETECTOR ASSEMBLY
FDC-FIRE DEPARTMENT CONNECTION.
- DCDA SHALL CONFORM TO REQUIREMENTS OF PUBLIC/PRIVATE AGENCIES HAVING JURISDICTION.
- DCDA & VAULT INSTALLATION SHALL MEET REQUIREMENTS OF OREGON HEALTH AUTHORITY, DRINKING WATER SERVICES (DWS).
- CONTRACTOR SHALL HAVE DCDA TESTED AND CERTIFIED PRIOR TO ACCEPTANCE BY OWNER.
- FDC SHALL NOT EXIT THROUGH THE TOP OF THE VAULT.
- ALL PIPE OPENINGS SHALL BE SEALED WITH NON-SHRINK WATERTIGHT GROUT.
- BENDS, CROSSES AND TEES SHALL NOT BE INSTALLED WITHIN 5 FEET OF THE OUTSIDE VAULT WALL.
- ALL VAULTS SHALL MEET OR EXCEED ASTM C-857. ALL VAULT CONCRETE TO BE 4500 PSI @ 28 DAYS. REBAR TO BE ASTM A-615 GRADE 60.
- SUMP PUMP WITH POWER SUPPLY SHALL BE INSTALLED UNLESS OTHERWISE APPROVED BY PUBLIC WORKS.
- SUMP PUMP DISCHARGE PIPE TO BE 1½-INCH SCHED 40 PVC SHALL BE PLUMBED TO FACE OF STREET CURB OR OTHER DISPOSAL POINT APPROVED BY LOCAL JURISDICTION (SEE OAR 333-061-0071.3.f).
- CONTRACTOR TO INSTALL SUMP PUMP (5 GPM MIN) WITH 120V POWER SUPPLY, ALONG WITH PRIVATE POWER SOURCE (RESPONSIBILITY OF CONTRACTOR INSTALLING VAULT). SCHED 40 CONDUIT, WIRE, ETC. FOR SUMP PUMP POWER SHALL CONFORM WITH NEC REQUIREMENTS.
- THRUST COLLAR CONCRETE SHALL BE 3300 PSI @ 28 DAYS.
- PROVIDE REMOTE READER (RADIO READ HEAD) FOR DETECTOR LOOP METER PER LOCAL JURISDICTION REQUIREMENTS, MOUNTED ON HINGE EDGE OF HATCH.
- ALUMINUM ANGLE FRAME HATCH (3'0"x 5'6" MIN) SHALL BE BY USF FABRICATION OR APPROVED EQUAL (SAND BLASTED NON-SLIP).
(1) TO BE 300 PSF PEDESTRIAN RATED WHERE LID IS SET MIN. OF 9" ABOVE GRADE.
(2) TO BE H-20 RATED IF LID IS LESS THAN 9" ABOVE GRADE, OR IF LOCATED IN TRAFFIC AREA.
- OSHA APPROVED GALVANIZED STEEL LADDER & ALUMINUM LADDER SAFETY EXTENSION.
- PER OFC 903.4, INSTALL APPROVED TAMPER SWITCH ON BOTH OS&Y VALVES IN VAULT, WIRED TO A LISTED FIRE ALARM CONTROL UNIT, UNLESS EXEMPTION IS GRANTED BY FIRE DEPT.

INSTALL "FORWARD FLOW TEST PORT" PER DTL 559 UNLESS ALT. LOCATION APPROVED.

LADDER & SAFETY EXTENSION

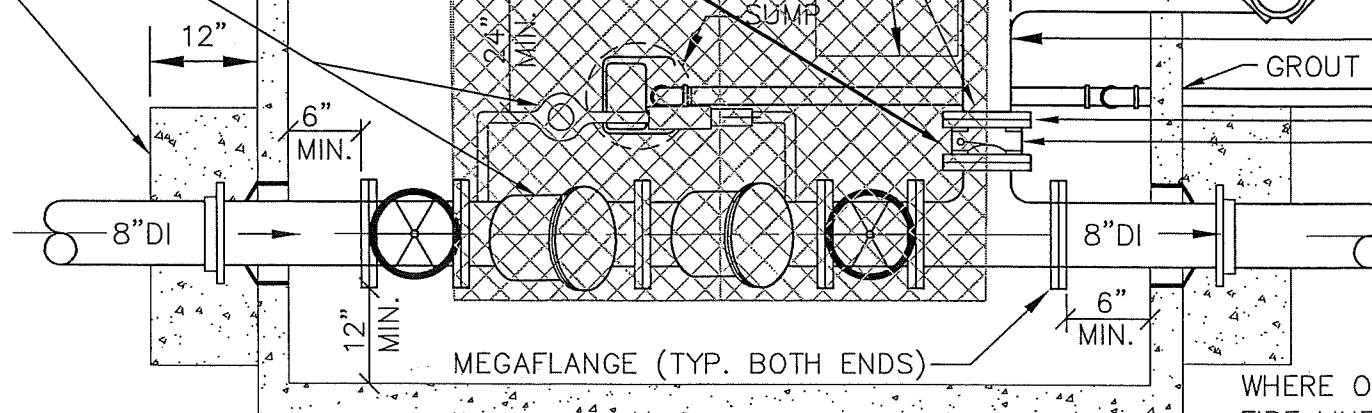

PLAN
NTS

SET TOP 1" MIN. ABOVE FG. OUTSIDE PAVED AREAS. USE H-20 RATED HATCH IF LID IS LESS THAN 9" ABOVE FG ON ALL SIDES.

ALUMINUM HATCH (SEE NOTE 14)

SET TOP AT FINISH GRADE IN PAVED AREAS

UTILITY VAULT

GRANULAR BACKFILL IN IMPROVED AREAS

CORE VAULT TO PIPE DIA +3" MIN, KOR-N-SEAL BOOT (TYP. BOTH ENDS)

TRUE UNION BALL VALVE

LADDER & SAFETY EXT. (SEE NOTE 15)

OS&Y GATE VALVE (TYP.)

8" DI

8" DI

12" MIN.

6" MIN. COMPACTED GRANULAR BASEROCK

STANDON MODEL S89 FLANGE SUPPORT OR APPROVED EQUAL (TYP).

SECTION
NTS

MIN 5 GPM SUMP PUMP WITH POWER SUPPLY. CONTRACTOR TO COORDINATE WITH BUILDING CONTRACTOR TO CONNECT SUMP PUMP TO BUILDING POWER.

LAST REVISION DATE: APR 2023	JO # STANDARD
---------------------------------	------------------

8" DOUBLE CHECK DETECTOR ASSEMBLY W/FDC
(NTS)

AUMSVILLE, OR	DETAIL NO. 556
---------------	-------------------

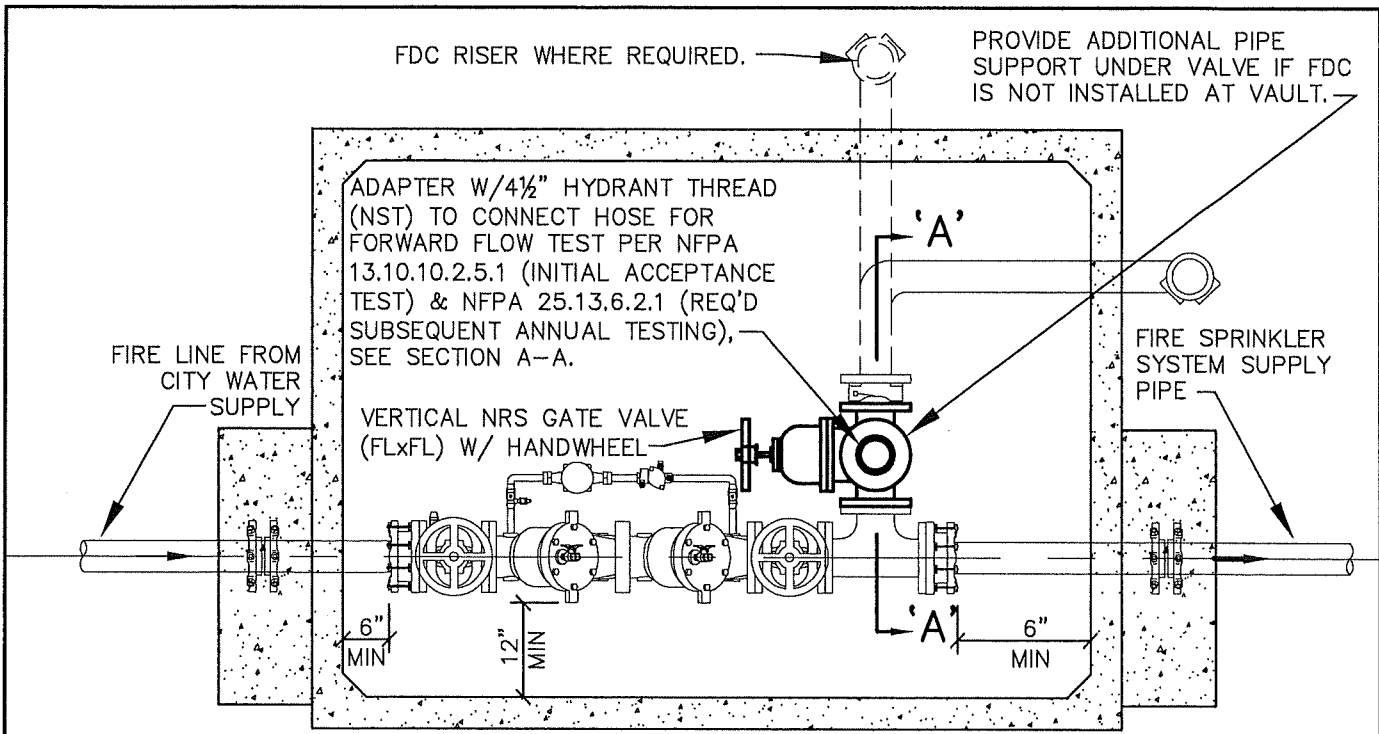

PLAN
NTS

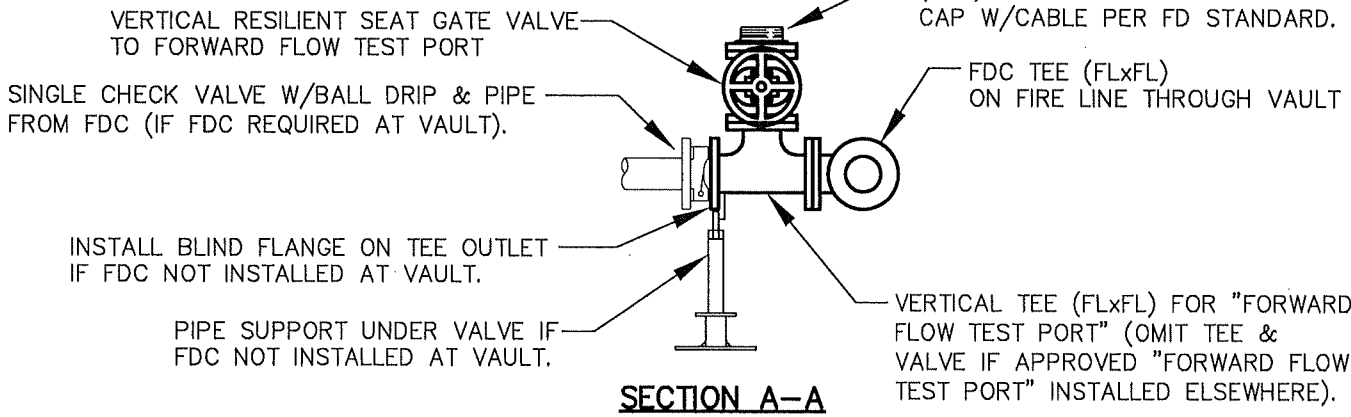

SECTION A-A
NTS

NOTES:

1. THE "FORWARD FLOW TEST PORT" SHALL BE INSTALLED IN THE DCDA VAULT AS SHOWN AND SPECIFIED BY THIS DETAIL, UNLESS AN ALTERNATE PERMANENT "FORWARD FLOW TEST PORT" LOCATION IS APPROVED IN WRITING BY THE OWNER'S REPRESENTATIVE AND AN AUTHORIZED FIRE DEPT REPRESENTATIVE, OR IF A PRIVATE FIRE HYDRANT DOWNSTREAM OF THE DCDA VAULT IS DESIGNATED AS THE REQUIRED "FORWARD FLOW TEST PORT".
2. CONTRACTOR IS RESPONSIBLE FOR COORDINATING WITH THE FIRE SPRINKLER SYSTEM DESIGNER/INSTALLER TO VERIFY THE FLOWRATE REQUIRED FOR THE "FORWARD FLOW TEST" OF THE BACKFLOW DEVICE, AND SHALL COORDINATE TO ENSURE THAT ALL HOSE & FLOW MEASUREMENT EQUIPMENT (HOSE MONSTER OR EQUAL) IS PROVIDED AS REQUIRED TO CONDUCT THE ACCEPTANCE "FORWARD FLOW TEST" AS REQUIRED BY NFPA 13.10.10.2.5.1.
3. ALL COMPONENTS OF THE FORWARD FLOW TEST PORT (EXCLUDING THE FIRE HOSES & FLOW MEASUREMENT EQUIPMENT) SHALL REMAIN IN PLACE TO ALLOW SUBSEQUENT "FORWARD FLOW TESTS" TO BE CONDUCTED WITHOUT ANY SYSTEM MODIFICATIONS (IE. ANNUAL FLOW TESTS AS REQUIRED PER NFPA 25.13.6.2.1).
4. CONFORM TO ALL OTHER REQUIREMENTS OF APPLICABLE DOUBLE CHECK DETECTOR ASSEMBLY DETAIL(S), NOTES & SPECIFICATIONS.

LAST REVISION DATE: FEB 2021	JO #
4" FORWARD FLOW TEST PORT INSIDE DCDA VAULT (FOR NFPA 13 & 25 TESTS) (NTS)	
AUMSVILLE, OR	DETAIL NO. 559

FIRE CONTRACTOR TO PROVIDE FDC SIGNS PER OFC 912, LOCATION PER FIRE CHIEF.

-FDC LINE CHECK VALVE & BALL DRIP VALVE TO BE INSTALLED IN AN ACCESSIBLE LOCATION (NFPA 13, 16.12.6.1 & NFPA 13, 16.12.7).

-CONTRACTOR TO VERIFY THAT BALL DRIP VALVE INSTALLED IS DESIGNED & LISTED FOR THE ORIENTATION USED (VERTICAL OR HORIZONTAL).

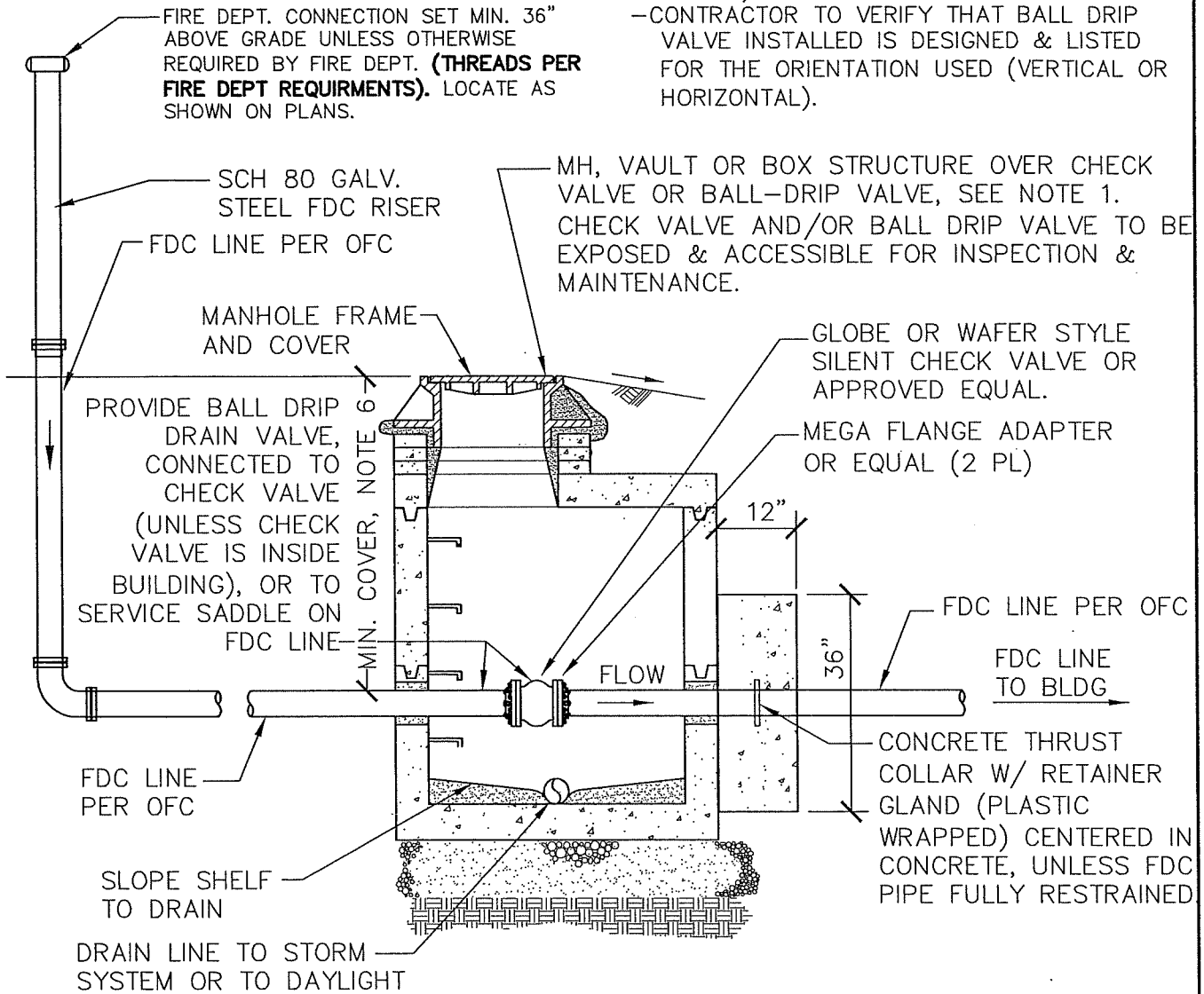

FIRE DEPT. CONNECTION SET MIN. 36" ABOVE GRADE UNLESS OTHERWISE REQUIRED BY FIRE DEPT. **(THREADS PER FIRE DEPT REQUIRMENTS)**. LOCATE AS SHOWN ON PLANS.

PROVIDE BALL DRIP DRAIN VALVE, CONNECTED TO CHECK VALVE (UNLESS CHECK VALVE IS INSIDE BUILDING), OR TO SERVICE SADDLE ON FDC LINE

MH, VAULT OR BOX STRUCTURE OVER CHECK VALVE OR BALL-DRIP VALVE, SEE NOTE 1. CHECK VALVE AND/OR BALL DRIP VALVE TO BE EXPOSED & ACCESSIBLE FOR INSPECTION & MAINTENANCE.

GLOBE OR WAFER STYLE SILENT CHECK VALVE OR APPROVED EQUAL.

MEGA FLANGE ADAPTER OR EQUAL (2 PL)

FDC LINE TO BLDG

FDC LINE PER OFC

SLOPE SHELF TO DRAIN

DRAIN LINE TO STORM SYSTEM OR TO DAYLIGHT

NOTES:

1. INSTALL 48" PRECAST MANHOLE PER DETAIL 402, UNLESS OTHER APPROVED VAULT OR BOX IS SHOWN OR NOTED ON DWGS.
2. ALL PIPE OPENINGS SHALL BE SEALED WITH NON-SHRINK WATERTIGHT GROUT.
3. WHERE REQUIRED, THRUST COLLAR CONCRETE SHALL BE 3300 PSI @ 28 DAYS.
4. IF AN FDC LINE CHECK VALVE IS PROVIDED INSIDE BUILDING, AN EXTERIOR FDC LINE CHECK VALVE IS NOT REQUIRED UNLESS OTHERWISE DIRECTED IN WRITING BY FIRE CODE OFFICIAL. A BALL DRIP AUTOMATIC DRAIN VALVE SHALL BE INSTALLED ON CHECK VALVE OR AT THE LOW POINT ON FDC LINE (DETAIL 562), TO DRAIN HORIZONTAL FDC LINE BETWEEN CHECK VALVE & FDC RISER.
5. PER NFPA 13, A10.4.2, 40" MIN COVER IS REQUIRED FOR "WET" FIRE LINES & FDC LINES (ANY PORTION OF LINES WHICH REMAIN FILLED WHEN NOT IN USE AND SUBJECT TO FREEZING). COVER DEPTH MAY BE REDUCED TO 30" MIN ON "DRY" FDC LINE WHICH IS DRAINED COMPLETELY WHEN NOT IN USE (NFPA 13, 6.4.2.2.2 & NFPA 24, 10.4.2.2.2).
6. THIS DETAIL PROVIDES GUIDANCE ONLY, AND DOES NOT SUPERCEDE REQUIREMENTS UNDER THE OREGON FIRE CODE, NFPA STANDARDS OR DIRECTION FROM FIRE CODE OFFICIAL.

LAST REVISION DATE: AUG 2022	JO # STANDARD
BELOW GRADE CHECK VALVE & BALL DRIP VALVE, IN CLOSE BOTTOM DRAIN STRUCT (NTS)	
AUMSVILLE, OR	DETAIL NO. 560

FIRE CONTRACTOR TO PROVIDE FDC SIGNS PER OFC 912, LOCATION PER FIRE CHIEF.

- FDC LINE CHECK VALVE & BALL DRIP VALVE TO BE INSTALLED IN AN ACCESSIBLE LOCATION (NFPA 13, 16.12.6.1 & NFPA 13, 16.12.7).
- CONTRACTOR TO VERIFY THAT BALL DRIP VALVE INSTALLED IS DESIGNED & LISTED FOR THE ORIENTATION USED (VERTICAL OR HORIZONTAL).

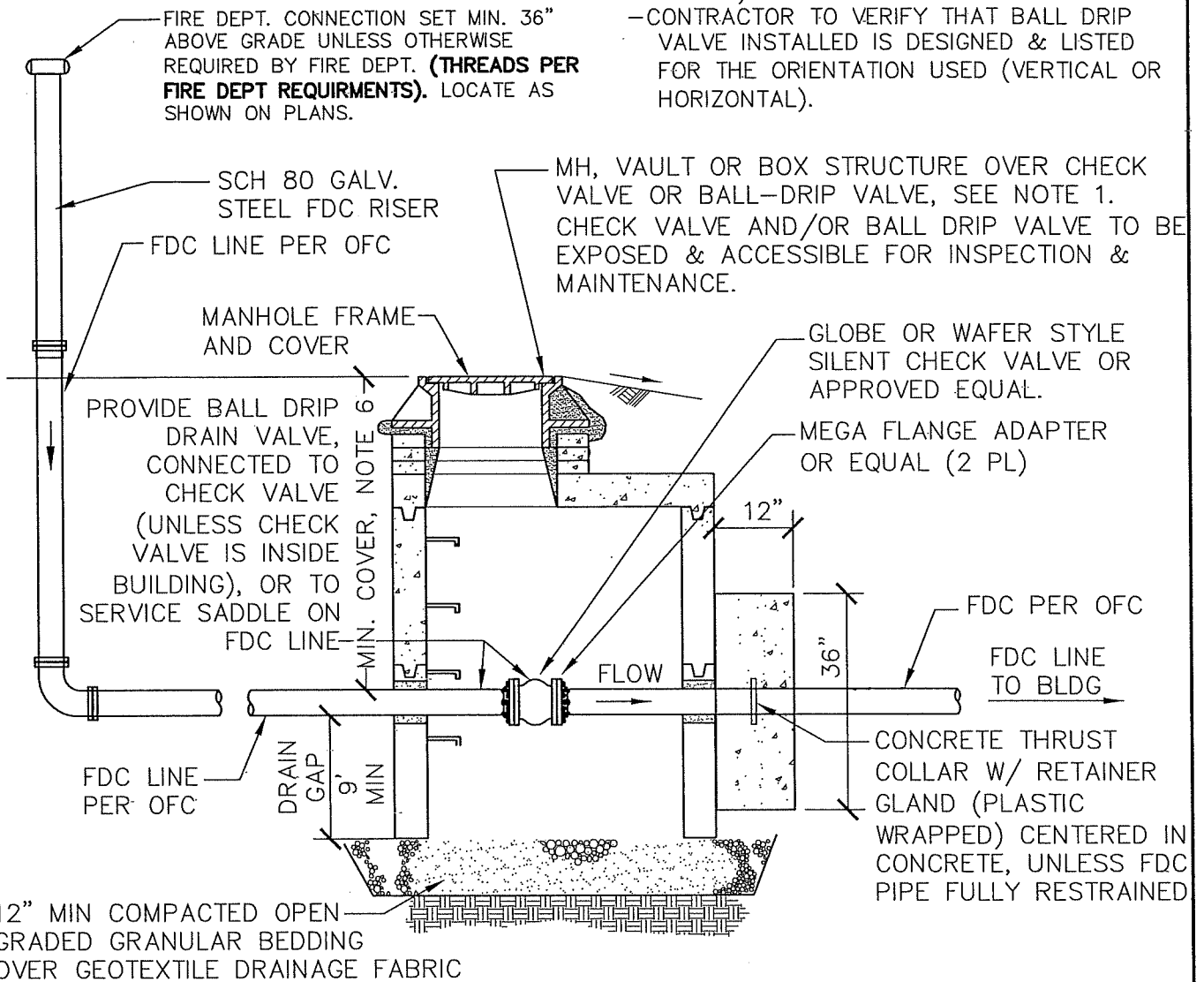

NOTES:

1. INSTALL 48" PRECAST MANHOLE PER DETAIL 402, UNLESS OTHER APPROVED VAULT OR BOX IS SHOWN OR NOTED ON DWGS.
2. ALL PIPE OPENINGS SHALL BE SEALED WITH NON-SHRINK WATERTIGHT GROUT.
3. WHERE REQUIRED, THRUST COLLAR CONCRETE SHALL BE 3300 PSI @ 28 DAYS.
4. IF AN FDC LINE CHECK VALVE IS PROVIDED INSIDE BUILDING, AN EXTERIOR FDC LINE CHECK VALVE IS NOT REQUIRED UNLESS OTHERWISE DIRECTED IN WRITING BY FIRE CODE OFFICIAL. A BALL DRIP AUTOMATIC DRAIN VALVE SHALL BE INSTALLED ON CHECK VALVE OR AT THE LOW POINT ON FDC LINE (DETAIL 562), TO DRAIN HORIZONTAL FDC LINE BETWEEN CHECK VALVE & FDC RISER.
5. PER NFPA 13, A10.4.2, 40" MIN COVER IS REQUIRED FOR "WET" FIRE LINES & FDC LINES (ANY PORTION OF LINES WHICH REMAIN FILLED WHEN NOT IN USE AND SUBJECT TO FREEZING). COVER DEPTH MAY BE REDUCED TO 30" MIN ON "DRY" FDC LINE WHICH IS DRAINED COMPLETELY WHEN NOT IN USE (NFPA 13, 6.4.2.2.2 & NFPA 24, 10.4.2.2.2).
6. THIS DETAIL PROVIDES GUIDANCE ONLY, AND DOES NOT SUPERCEDE REQUIREMENTS UNDER THE OREGON FIRE CODE, NFPA STANDARDS OR DIRECTION FROM FIRE CODE OFFICIAL.

LAST REVISION DATE: SEPT 2022	JO # STANDARD
BELOW GRADE CHECK VALVE & BALL DRIP VALVE, IN OPEN BOTTOM DRAIN STRUCTURE (NTS)	
AUMSVILLE, OR	DETAIL NO. 561

FIRE CONTRACTOR TO PROVIDE FDC SIGNS PER OFC 912, LOCATION PER FIRE CHIEF.

- FDC LINE CHECK VALVE & BALL DRIP VALVE TO BE INSTALLED IN AN ACCESSIBLE LOCATION (NFPA 13, 16.12.6.1 & NFPA 13, 16.12.7).
- CONTRACTOR TO VERIFY THAT BALL DRIP VALVE INSTALLED IS DESIGNED & LISTED FOR THE ORIENTATION USED (VERTICAL OR HORIZONTAL).

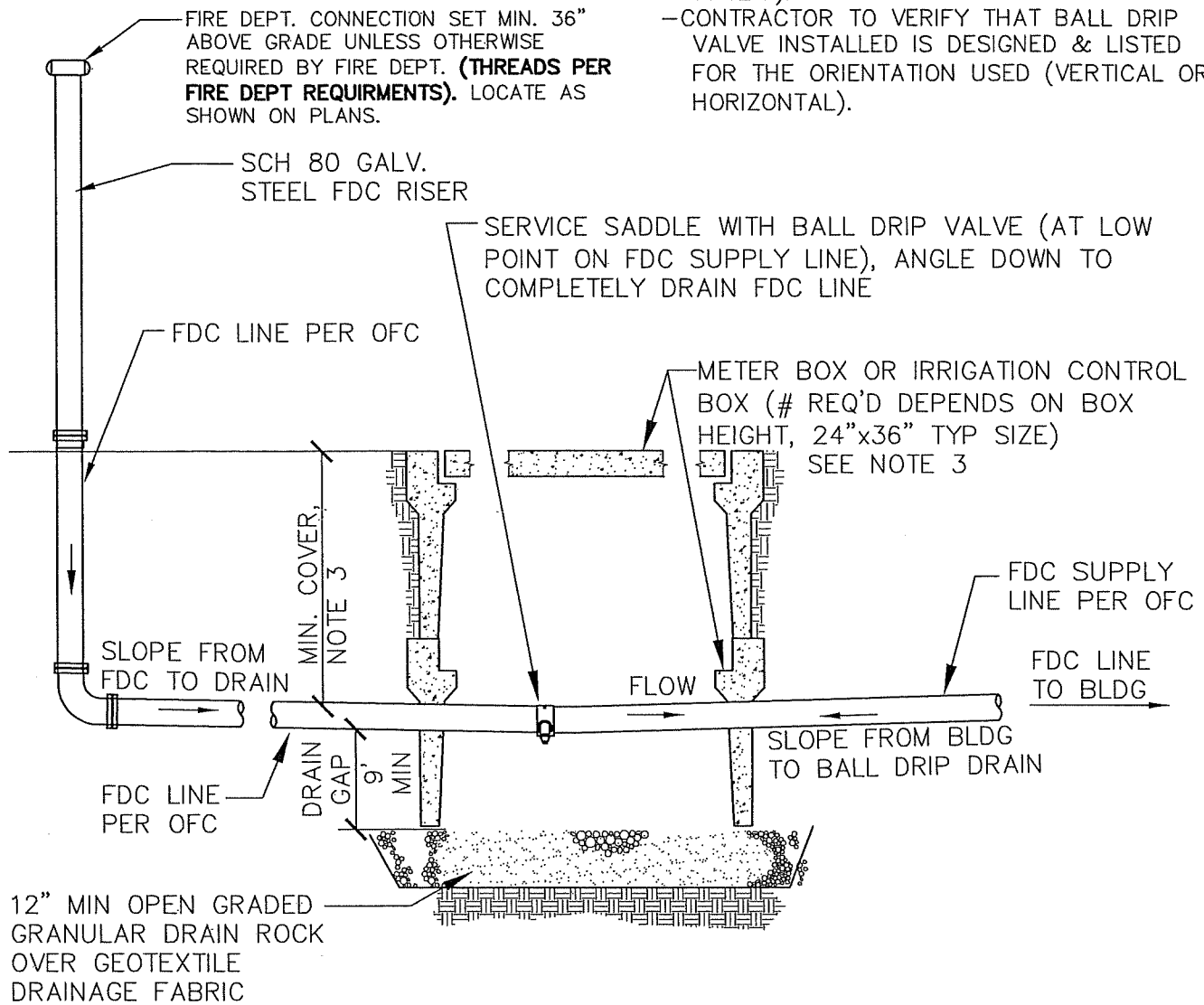

NOTES:

1. INSTALL BALL-DRIP DRAIN VALVE & BOX AT LOW POINT IN FDC LINE PROFILE (IE. BALL DRIP VALVE SHALL BE CONFIGURED TO DRAIN ENTIRE HORIZONTAL FDC PIPE BETWEEN FDC RISER & BUILDING WHEN FDC IS NOT IN USE).
2. CONFIGURATION SHOWN IS BASED ON FDC LINE CHECK VALVE INSIDE BUILDING (IE. FDC LINE "DRY" WHEN NOT IN USE).
3. UNLESS DEEPER DEPTH REQUIRED TO ADDRESS UTILITY CONFLICTS OR OTHER ISSUES, COVER DEPTH FOR "DRY" FDC LINE SHALL BE 30" MIN AT ALL LOCATIONS (NFPA 13, 6.4.2.2.2 & NFPA 24, 10.4.2.2.2).
4. BALL DRIP VALVE SHALL BE ACCESSIBLE IN BOX FOR INSPECTION & MAINTENANCE AS SHOWN (PROVIDE LARGER BOXES AS NECESSARY TO ACCOMPLISH THIS).
5. THIS DETAIL PROVIDES GUIDANCE ONLY, AND DOES NOT SUPERCEDE REQUIREMENTS UNDER THE OREGON FIRE CODE, NFPA STANDARDS OR DIRECTION FROM FIRE CODE OFFICIAL.

LAST REVISION DATE: SEPT 2022	JO # STANDARD
FDC LINE BALL DRIP DRAIN VALVE (CHECK VALVE IN BLDG) OPEN BOTTOM DRAIN STRUCT	
(NTS)	
AUMSVILLE, OR	DETAIL NO. 562

FIRE CONTRACTOR TO PROVIDE FDC SIGNS PER OFC 912, LOCATION PER FIRE CHIEF.

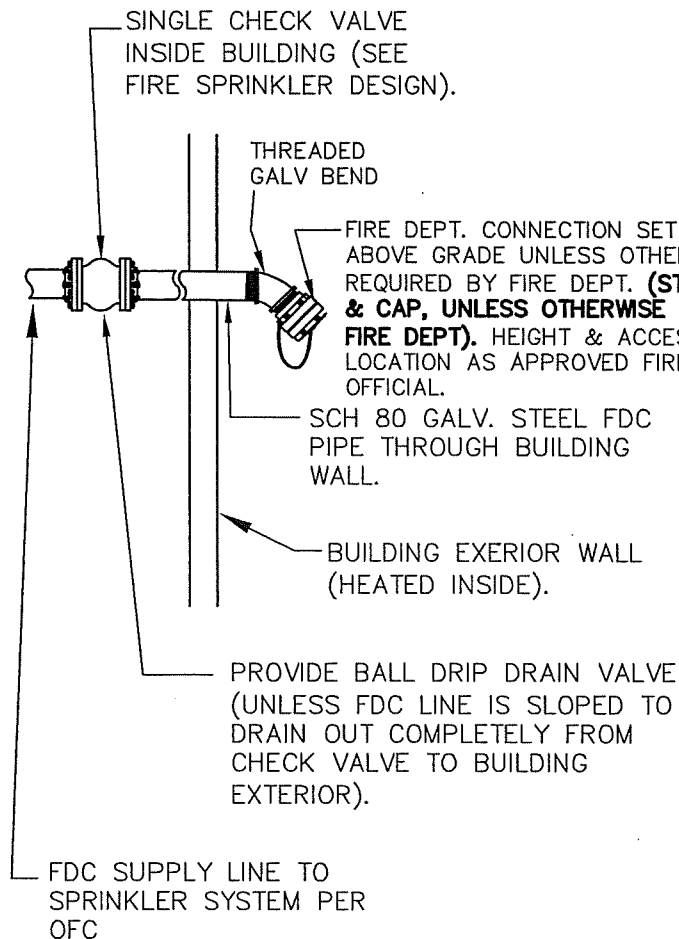

- FDC LINE CHECK VALVE & BALL DRIP VALVE TO BE INSTALLED IN AN ACCESSIBLE LOCATION (NFPA 13, 16.12.6.1 & NFPA 13, 16.12.7).
- CONTRACTOR TO VERIFY THAT BALL DRIP VALVE INSTALLED IS DESIGNED & LISTED FOR THE ORIENTATION USED (VERTICAL OR HORIZONTAL).

FORWARD FLOW TEST PORT NOTES:

1. A PERMANENT VALVED "FORWARD FLOW TEST PORT" SHALL BE INSTALLED AT A LOCATION AS APPROVED IN WRITING BY THE FIRE CODE OFFICIAL, UNLESS A PRIVATE FIRE HYDRANT DOWNSTREAM OF THE DCDA IS DESIGNATED AS THE REQUIRED "FORWARD FLOW TEST PORT".
2. CONTRACTOR IS RESPONSIBLE FOR COORDINATING WITH THE FIRE SPRINKLER SYSTEM DESIGNER/ INSTALLER TO VERIFY THE FLOWRATE REQUIRED FOR THE "FORWARD FLOW TEST" OF THE BACKFLOW DEVICE, AND SHALL COORDINATE TO ENSURE THAT ALL HOSE & FLOW MEASUREMENT EQUIPMENT (HOSE MONSTER OR EQUAL) IS PROVIDED AS REQUIRED TO CONDUCT THE ACCEPTANCE "FORWARD FLOW TEST" AS REQUIRED BY NFPA 13.10.10.2.5.1.
3. ALL COMPONENTS OF THE FORWARD FLOW TEST PORT (EXCLUDING THE FIRE HOSES & FLOW MEASUREMENT EQUIPMENT) SHALL REMAIN IN PLACE TO ALLOW SUBSEQUENT "FORWARD FLOW TESTS" TO BE CONDUCTED WITHOUT ANY SYSTEM MODIFICATIONS (IE. ANNUAL FLOW TESTS AS REQUIRED PER NFPA 25.13.6.2.1).
4. CONFORM TO ALL OTHER REQUIREMENTS OF APPLICABLE DOUBLE CHECK DETECTOR ASSEMBLY DETAIL(S), NOTES & SPECIFICATIONS (INCLUDING PROVISION OF AN APPROVED WATER METER & READ HEAD ON THE DCDA DETECTOR LOOP).

FORWARD FLOW TEST DRAIN NOTE:

1. IF THE FORWARD FLOW TEST PORT IS INSTALLED INSIDE A BUILDING, DRAINS ADEQUATE TO HANDLE THE FULL TEST FLOWS SHALL BE PROVIDED, UNLESS PROVISIONS ARE INCLUDED TO DIRECT THE TEST FLOWS TO THE EXTERIOR OF THE BUILDING IN A LOCATION WHICH WILL NOT CAUSE DAMAGE TO PUBLIC OR PRIVATE PROPERTY

BALL DRIP NOTES:

1. INSTALL BALL-DRIP DRAIN VALVE AT LOW POINT IN FDC LINE PROFILE (UNLESS FDC LINE IS SLOPED TO DRAIN OUT COMPLETELY FROM CHECK VALVE TO BUILDING EXTERIOR WHEN FDC IS NOT IN USE).
2. THIS DETAIL PROVIDES GUIDANCE ONLY, AND DOES NOT SUPERCEDE REQUIREMENTS UNDER THE OREGON FIRE CODE, NFPA STANDARDS OR DIRECTION FROM FIRE CODE OFFICIAL.

LAST REVISION DATE: APR 2023	JO # STANDARD
FDC ON BUILDING EXTERIOR & FORWARD FLOW TEST PORT, SAMPLE & NOTES (NTS)	
AUMSVILLE, OR	DETAIL NO. 563

WATERLINE PRESSURE TEST REPORT

Project Location:	Project Name:	Date:
Inspector: (Print)	Waterline to be tested. From Station:	To Station:
Verify that all in-line valves, including hydrant mainline valves, are open? Yes / No		
Verify that all corp stops are open? Yes / No		
Verify that pressure gauge is mounted at high point of line to be tested? Yes / No If no, correct for elevation difference (<i>ie. add 0.433 psi per foot elevation difference</i>).		
System Static Pressure (psi):	Starting Pressure (psi): <i>(greater of 150 psi or 1.5 times static)</i>	Ending Pressure (psi):
Pipe Lengths & ϕ 's:	Starting Time:	Ending Time (<i>2 hours minimum</i>):
Volume Required to Reach Initial Test Pressure (gal):	Allowable Leakage (gal): <i>(2 times table or calculated value below)</i>	Measured Leakage (gal):
TEST RESULTS: Pass / Fail		

ALLOWABLE LEAKAGE PER 1,000 FEET OF PIPELINE - gph (*NOTE: double the values from table below for a 2 hour test*)

Test Pressure <i>psi</i>	NOMINAL PIPE DIAMETER - <i>in.</i>									
	3	4	6	8	10	12	14	16	18	20
200	0.32	0.43	0.64	0.85	1.06	1.28	1.48	1.70	1.91	2.12
175	0.30	0.40	0.59	0.80	0.99	1.19	1.39	1.59	1.79	1.98
150	0.28	0.37	0.55	0.74	0.92	1.10	1.29	1.47	1.66	1.84

If the pipeline under test contains various diameters, the allowable leakage shall be the sum of the allowable leakage for each size. No additional leakage allowance will be given for fire hydrant assemblies or valves.

Sample: 700' 8" and 55' 6" pipe. $\rightarrow \rightarrow 0.74 \text{ gph} / 1,000' * 700' + (0.55 \text{ gph} / 1,000' * 55') = 0.548 \text{ gph} * 2 \text{ hours} = \sim 1.1 \text{ gallon allowable leakage loss.}$

Allowable leakage based on : $L = SD(P)^{1/2} / 133,200$

Where:

L = allowable leakage, in gallons per hour D = nominal diameter of the pipe, in inches
S = length of pipe tested, in feet P = test pressure during the leakage test, in psig

Regardless of leakage, maximum pressure drop during test period shall not exceed 5 psi over the 2 hour test period .

Any visible leaks shall be repaired regardless of the whether or not the pipeline meets leakage allowance.

TEST PROCEDURE

1. Apply hydrostatic pressure by pumping water from an auxiliary supply basin. Accurately determine the amount of water required to reach the initial test pressure by refilling the supply basin with a calibrated container following pressurization of pipeline.
2. Monitor test pressure for 2 hour period.
3. At the completion of the test period, re-pressurize the pipeline by pumping water from the auxiliary supply basin (*mark the water surface level in the auxiliary supply basin prior to re-pressurization*).
4. **Accurately determine the amount of water required to reach the test pressure by refilling the supply basin to the marked line with a calibrated container following re-pressurization of pipeline.** If the measured leakage is less than the allowable leakage, the test is successful.

Reference: For summary of disinfection & bacteriological testing procedures, see construction notes under Appendix B.

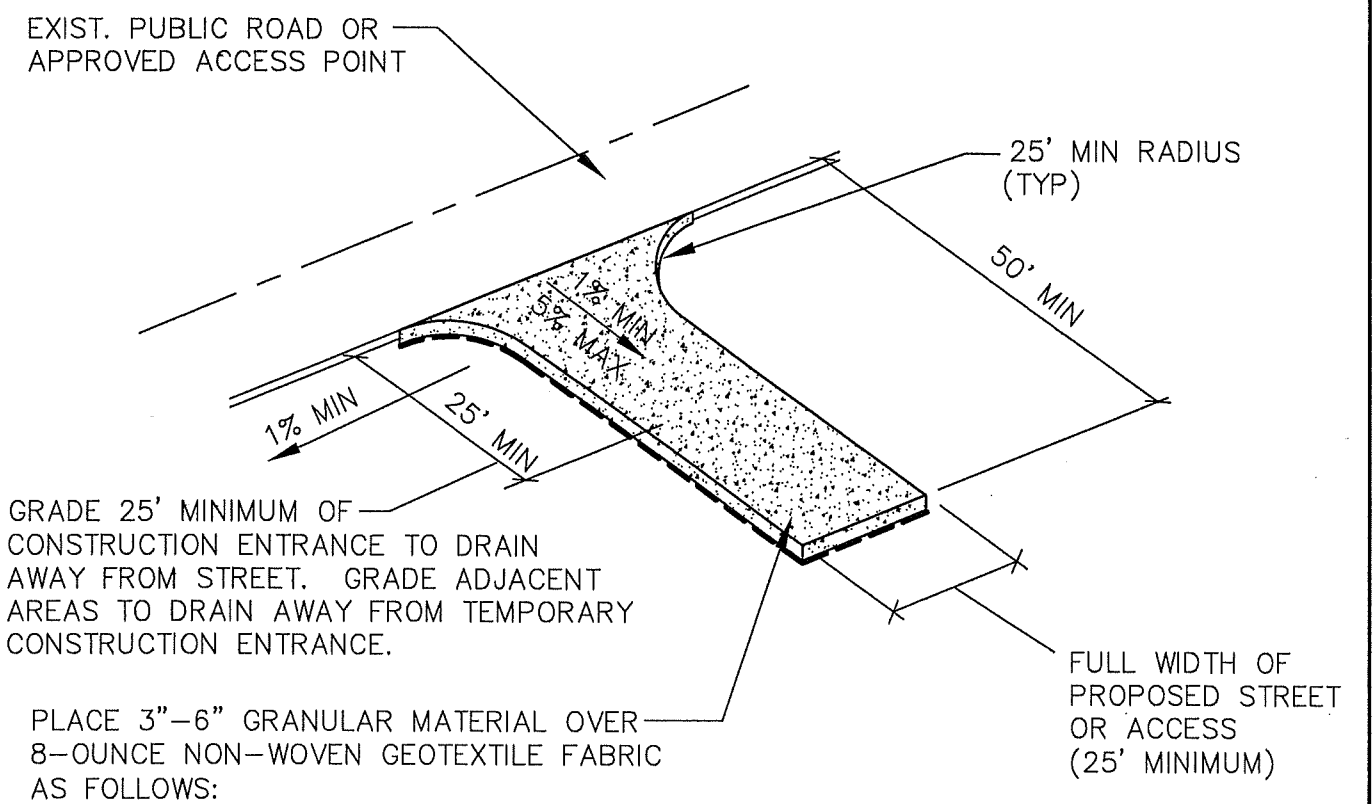

DRY WEATHER ACCESS

14-INCH MIN. DEPTH OVER COMPACTED SUBGRADE & FABRIC

WET WEATHER ACCESS

24-INCH MIN. DEPTH OVER UNDISTURBED SUBGRADE & FABRIC

CONSTRUCTION NOTES:

1. THE AREA OF THE CONSTRUCTION ENTRANCE SHALL BE STRIPPED OF ALL TOPSOIL, VEGETATION, ROOTS, AND OTHER NON-COMPACTABLE MATERIAL.
2. SUBGRADE SHALL BE COMPACTED AND PROOFROLLED PRIOR TO PLACEMENT OF GRANULAR MATERIAL. FAILURE TO PASS PROOFROLL WILL REQUIRE USE OF WET WEATHER SECTION.
3. FAILURE OR PUMPING OF THE DRY WEATHER SECTION WILL REQUIRE REMOVAL OF THE GRANULAR MATERIAL AND INSTALLATION OF THE WET WEATHER SECTION.

MAINTENANCE NOTES:

1. THE ENTRANCE SHALL BE MAINTAINED IN A CONDITION THAT WILL PREVENT TRACKING OR FLOW OF SEDIMENT ONTO PUBLIC RIGHT-OF-WAY. THIS MAY REQUIRE PERIODIC TOP DRESSING WITH 3"-6" INCH STONE AS CONDITIONS DEMAND, AND REPAIR AND/OR CLEAN-OUT OF STRUCTURES USED TO TRAP SEDIMENT.
2. ALL MATERIALS SPILLED, DROPPED, WASHED OR TRACKED FROM VEHICLES ONTO ROADWAYS OR INTO STORM DRAINS MUST BE REMOVED IMMEDIATELY.
3. ALL TRUCKS TRANSPORTING SATURATED SOILS SHALL BE WELL SEALED. WATER DRIPPAGE FROM TRUCKS MUST BE REDUCED TO 1 GALLON PER HOUR PRIOR TO LEAVING THE SITE.

LAST REVISION DATE: FEB 2021	JO # STANDARD
TEMPORARY CONSTRUCTION ENTRANCE (NTS)	
AUMSVILLE, OR	DETAIL NO. 610

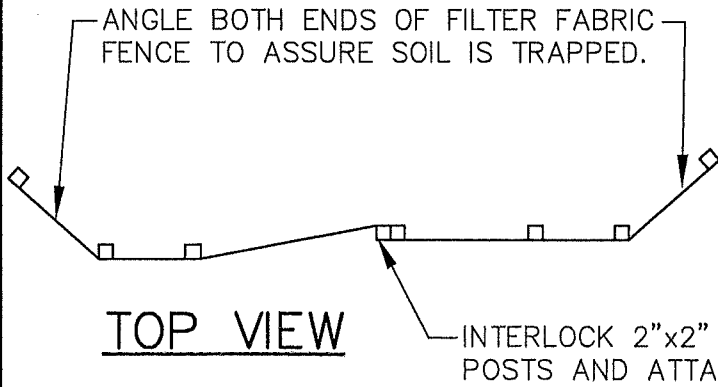

SILT FENCE NOTES:

1. BURY BOTTOM OF FILTER FABRIC 6" VERTICALLY BELOW FINISHED GRADE.
2. TRENCH TO BE DUG WITH DITCH-WITCH, BY HAND OR OTHER METHOD AS REQUIRED TO MINIMIZE WIDTH.
3. BACKFILL & COMPACT NATIVE SOIL IN TRENCH AFTER FENCE INSTALLATION.
4. STITCHED LOOPS TO BE INSTALLED TO THE UPHILL SIDE OF THE FENCE.

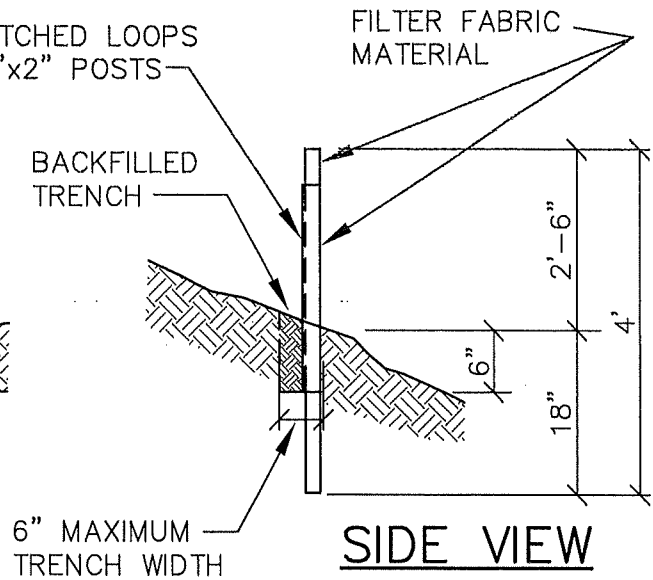
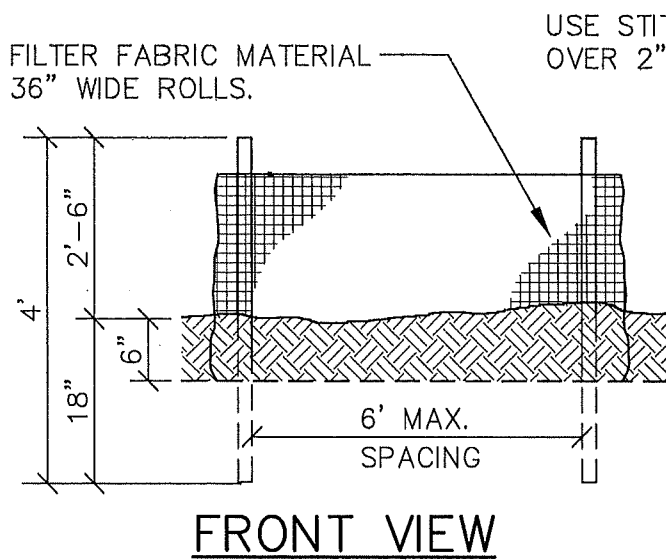

MAINTENANCE NOTES:

1. SEDIMENT BARRIERS SHALL BE MAINTAINED UNTIL UP-SLOPE AREA IS PERMANENTLY STABILIZED.
2. AT NO TIME SHALL MORE THAN ONE FOOT OF SEDIMENT BE ALLOWED TO ACCUMULATE BEHIND SEDIMENT FENCES OR BIOFILTER BAGS.
3. NEW SEDIMENT BARRIERS SHALL BE INSTALLED UPHILL AS REQUIRED TO CONTROL SEDIMENT TRANSPORT.

LAST REVISION DATE: FEB 2021	JO # STANDARD
SEDIMENT BARRIERS	
(NTS)	
AUMSVILLE, OR	DETAIL NO. 611

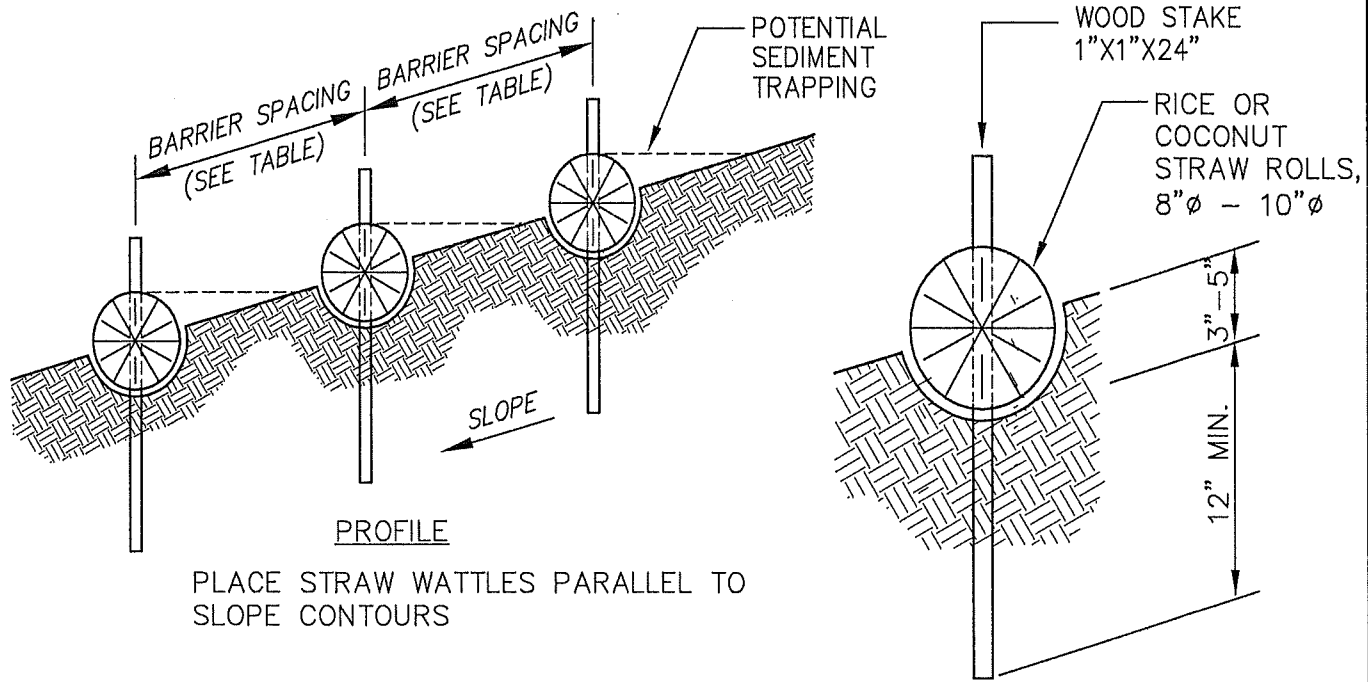

PROFILE
 PLACE STRAW WATTLES PARALLEL TO
 SLOPE CONTOURS

SECTION

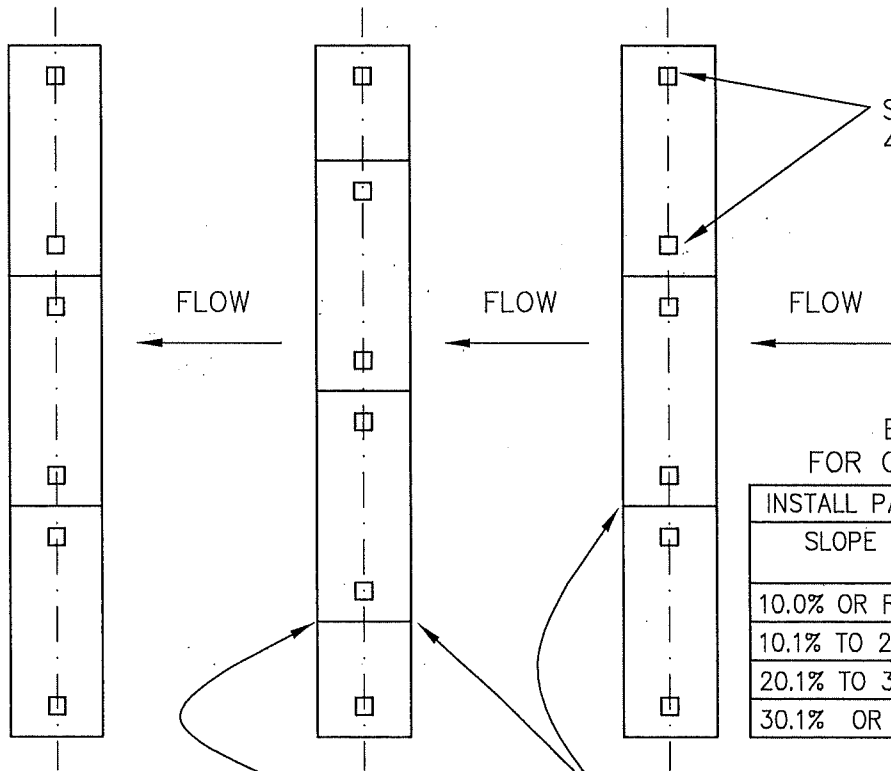

BARRIER SPACING
 FOR GENERAL APPLICATION

INSTALL PARALLEL TO CONTOURS AS FOLLOWS	
SLOPE RATIO	MAXIMUM SPACING ON SLOPE BETWEEN WATTLES
10.0% OR FLATTER	50' O.C.
10.1% TO 20.0%	25' O.C.
20.1% TO 30.0%	10' O.C.
30.1% OR STEEPER	5' O.C.

TIGHTLY ABUT
 ADJACENT WATTLES

PLAN

STAGGER
 JOINTS

- NOTES:
1. ALL MATERIAL SHALL CONFORM TO OSSC (ODOT/APWA) SPECIFICATIONS, CURRENT EDITION.
 2. SEDIMENT BARRIERS SHALL BE MAINTAINED UNTIL UP-SLOPE AREA IS PERMANENTLY STABILIZED.
 3. AT NO TIME SHALL SEDIMENT BE ALLOWED TO ACCUMULATE ABOVE THE TOP OF THE STRAW WATTLE.
 4. NEW SEDIMENT BARRIERS SHALL BE INSTALLED UPHILL AS REQUIRED TO CONTROL SEDIMENT TRANSPORT.

LAST REVISION DATE: FEB 2021	JO # STANDARD
STRAW WATTLE SEDIMENT BARRIER	
(NTS)	
AUMSVILLE, OR	DETAIL NO. 612

MAY BE USED SHORT TERM
W/UTILITY WORK AND WITH
PHASING OF DEVELOPMENT.

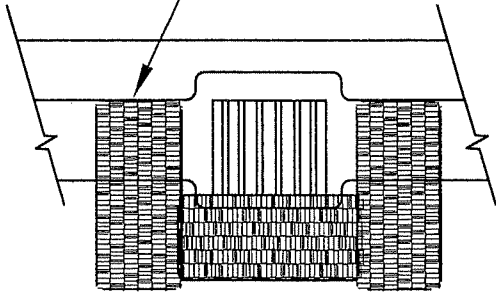

CURB INLET C.B.

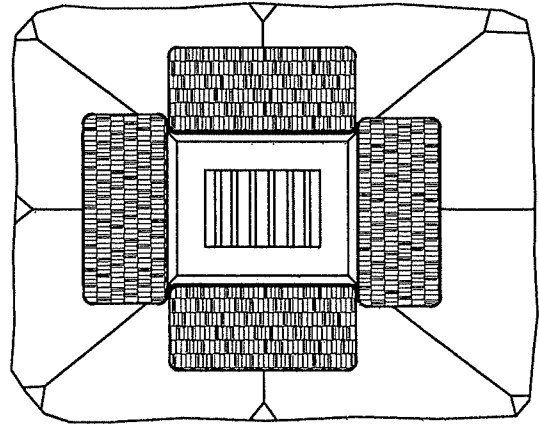

AREA DRAIN

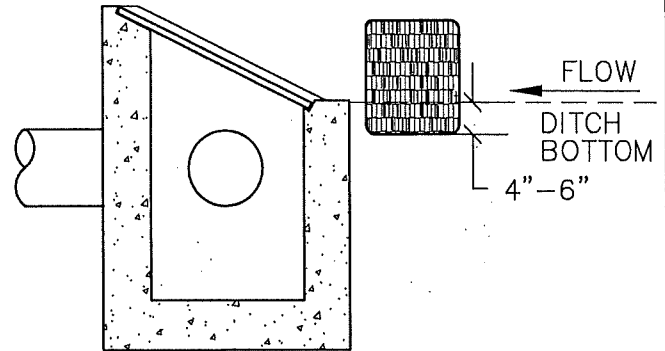
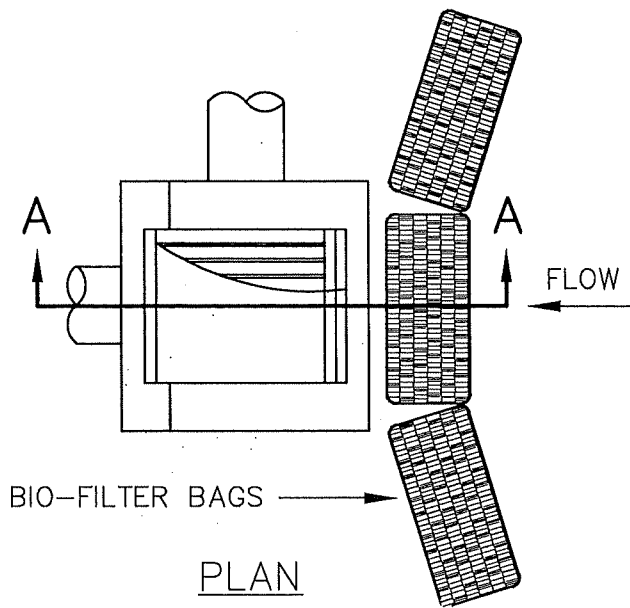

SECTION A-A

DITCH INLET C.B.

MAINTENANCE NOTES:

1. SEDIMENT BARRIERS SHALL BE MAINTAINED UNTIL UP-SLOPE AREA IS PERMANENTLY STABILIZED.
2. AT NO TIME SHALL MORE THAN ONE FOOT OF SEDIMENT BE ALLOWED TO ACCUMULATE BEHIND SEDIMENT FENCES OR BIOFILTER BAGS.
3. NEW SEDIMENT BARRIERS SHALL BE INSTALLED UPHILL AS REQUIRED TO CONTROL SEDIMENT TRANSPORT.

LAST REVISION DATE: FEB 2021	JO # STANDARD
INLET SEDIMENT CONTROL	
(NTS)	
AUMSVILLE, OR	DETAIL NO. 613

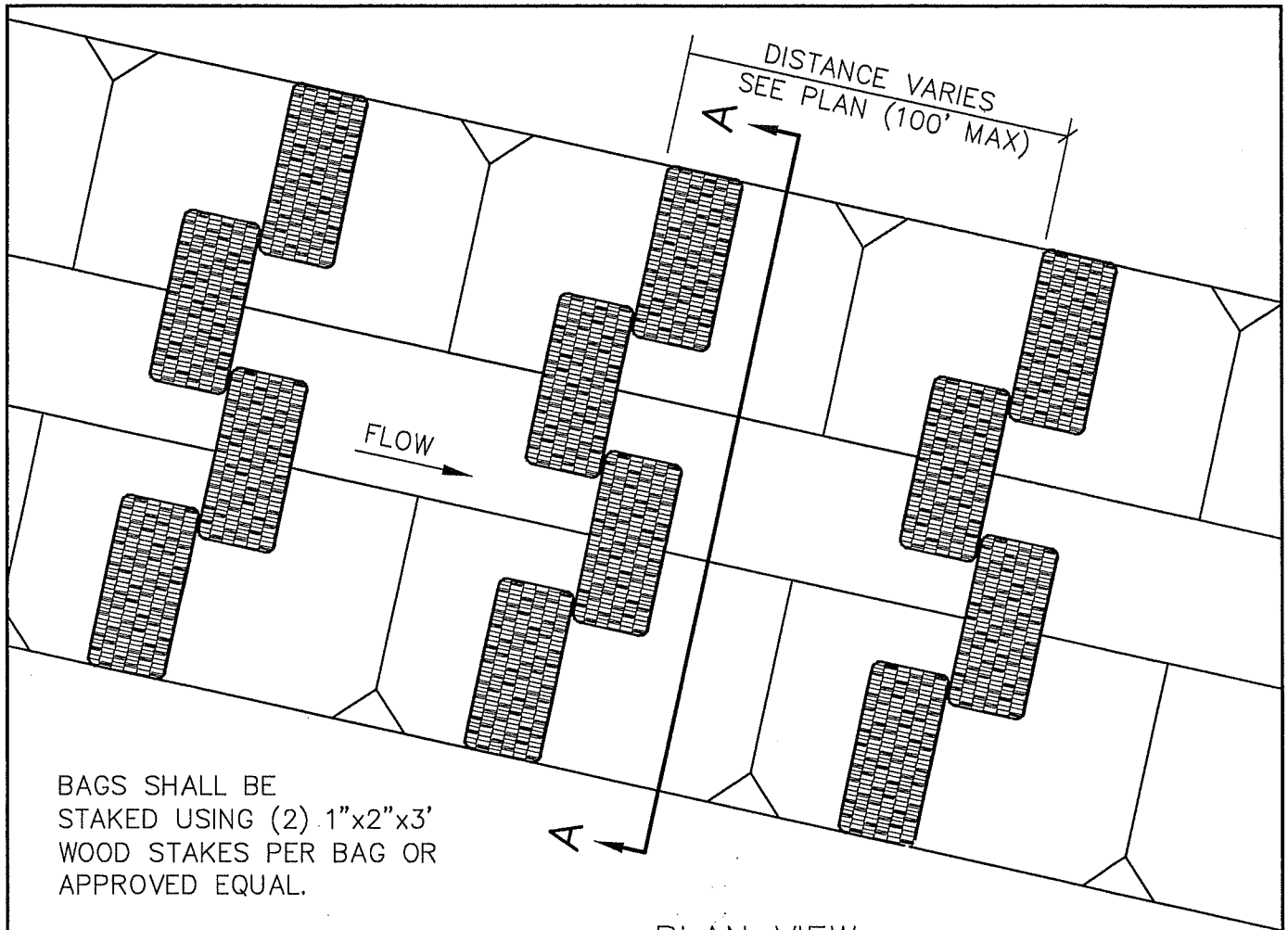

BAGS SHALL BE STAKED USING (2) 1"x2"x3' WOOD STAKES PER BAG OR APPROVED EQUAL.

PLAN VIEW

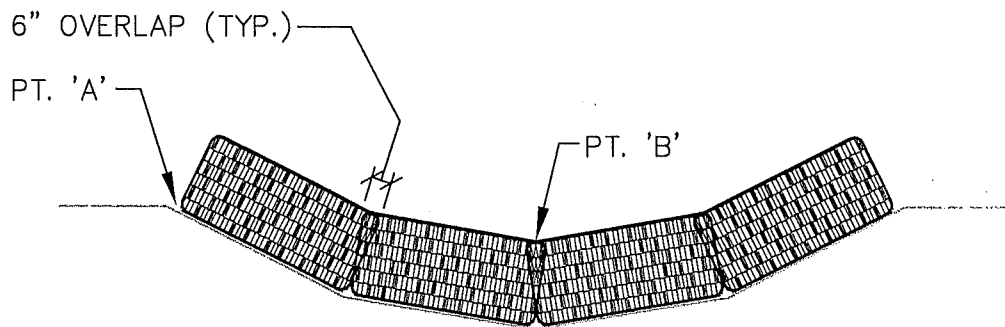

SECTION A-A

MAINTENANCE NOTES:

1. SEDIMENT BARRIERS SHALL BE MAINTAINED UNTIL UP-SLOPE AREA IS PERMANENTLY STABILIZED.
2. AT NO TIME SHALL MORE THAN ONE FOOT OF SEDIMENT BE ALLOWED TO ACCUMULATE BEHIND BIOFILTER BAGS.
3. NEW SEDIMENT BARRIERS SHALL BE INSTALLED UPHILL AS REQUIRED TO CONTROL SEDIMENT TRANSPORT.
4. PT. 'A' SHALL BE 6" MIN. HIGHER THAN PT. 'B'.

LAST REVISION DATE: FEB 2021	JO # STANDARD
DITCH AND SWALE EROSION PROTECTION	
(NTS)	
AUMSVILLE, OR	DETAIL NO. 614

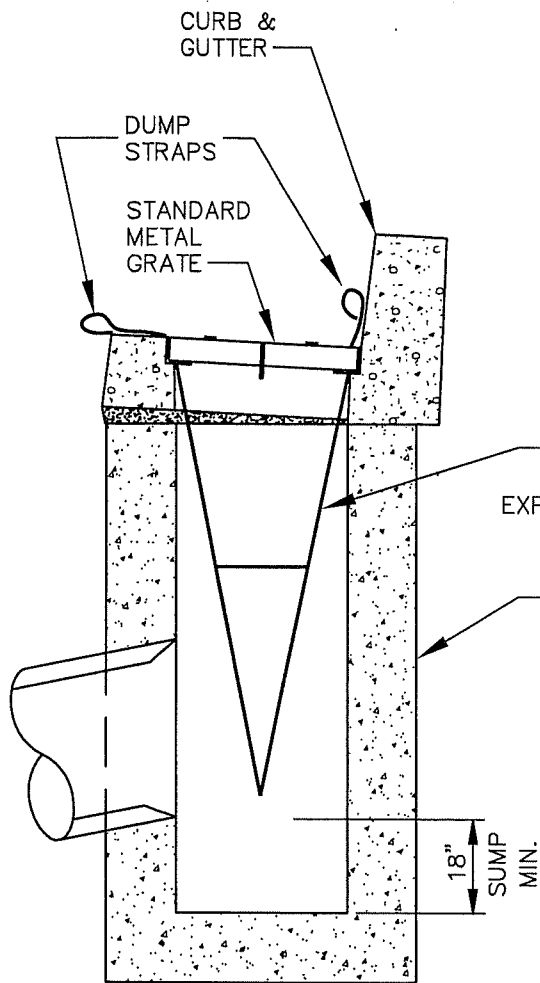

INSTALLATION DETAIL

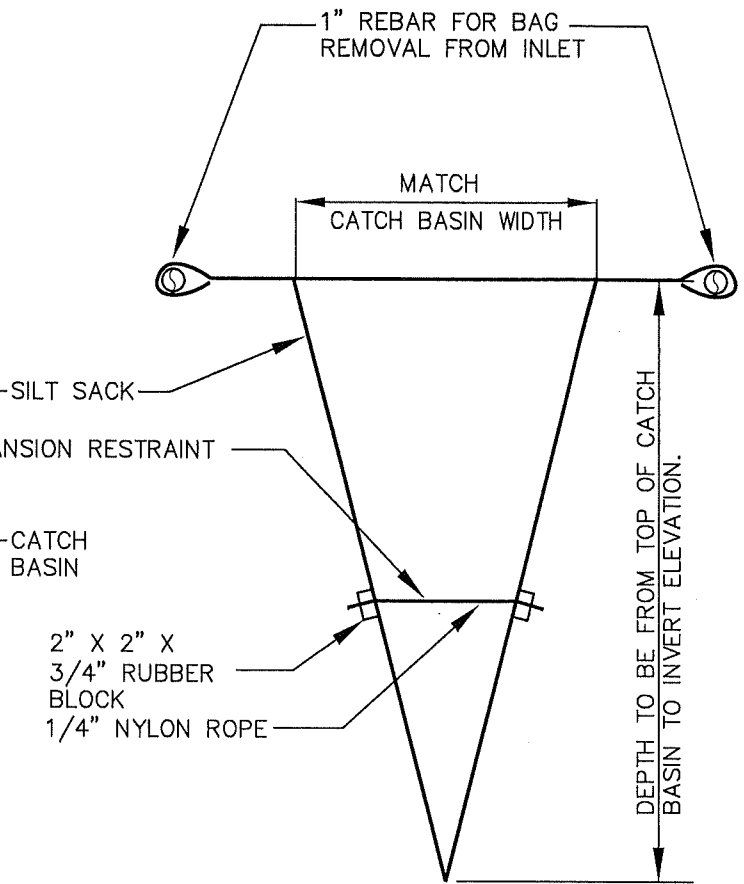

BAG DETAIL

NOTES:

1. EMPTY SILT SACK AS NECESSARY.
2. SILTSACK SEDIMENT CONTROL DEVICE AS MANUFACTURED BY ACF ENVIRONMENTAL AND SUPPLIED BY ACF WEST (503) 771-5115 OR APPROVED EQUAL.

LAST REVISION DATE: FEB 2021	
SILT SACK INLET DETAIL	
(NTS)	
AUMSVILLE, OR	DETAIL NO. 615

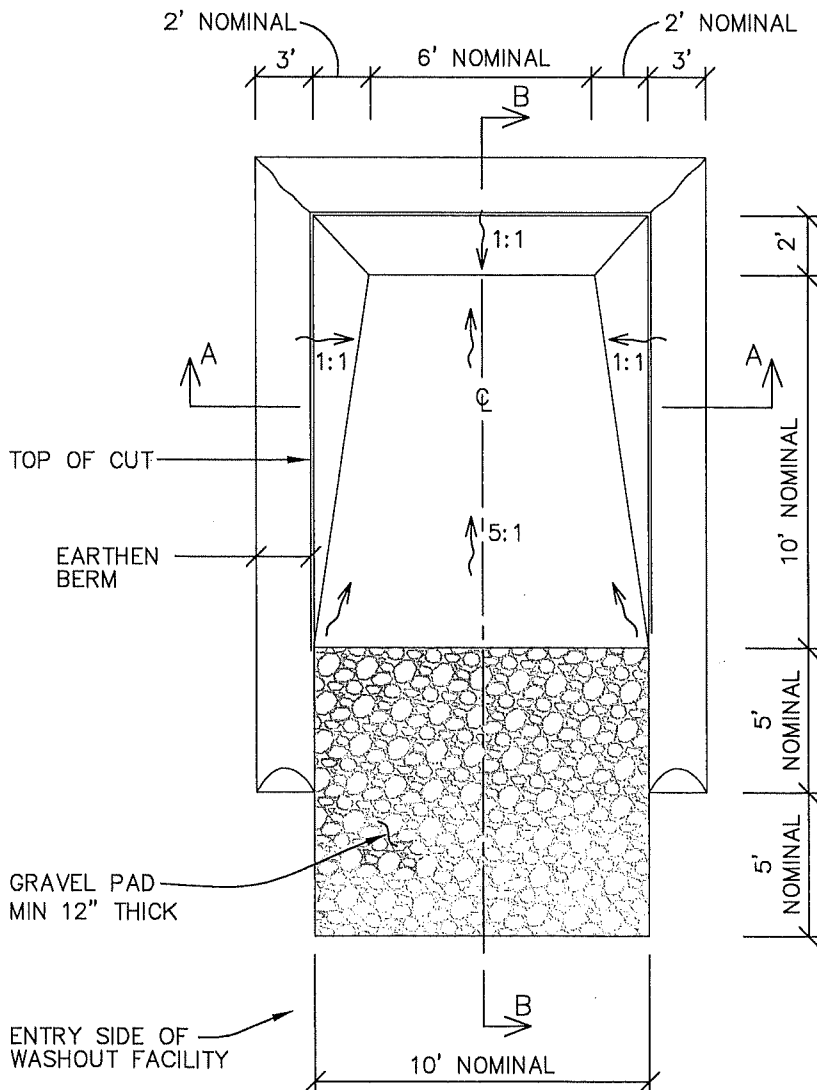
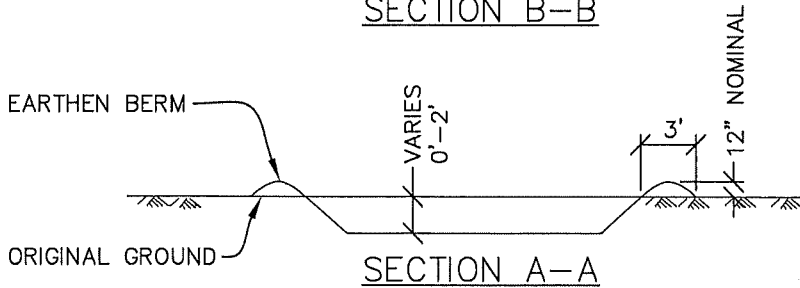
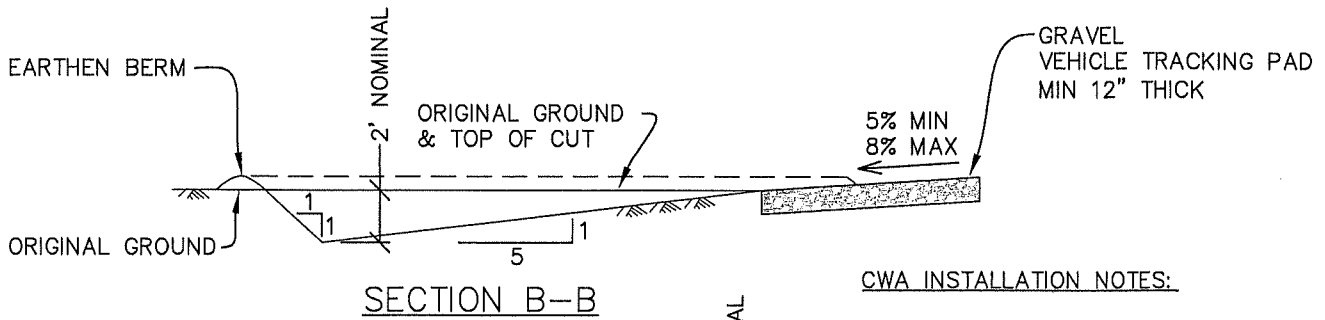

CWA INSTALLATION NOTES:

1. SEE DRAWINGS FOR CWA INSTALLATION LOCATION.
2. DO NOT LOCATE WASHOUT AREA WITHIN 200' OF ANY NATURAL DRAINAGE WAY.
3. THE CWA SHALL BE INSTALLED PRIOR TO CONCRETE PLACEMENT ON SITE.
4. VEHICLE TRACKING PAD SHALL BE SLOPED 5% TOWARDS THE CWA.

CWA MAINTENANCE NOTES:

1. INSPECT BMP'S EACH WORKDAY, AND MAINTAIN THEM IN EFFECTIVE OPERATING CONDITION.
2. THE CWA SHALL BE REPAIRED, CLEANED, OR ENLARGED AS NECESSARY TO MAINTAIN CAPACITY FOR CONCRETE WASTE. CONCRETE MATERIALS ACCUMULATED IN PIT SHALL BE REMOVED ONCE THE MATERIALS HAVE REACHED A DEPTH OF 18".
3. CONCRETE WASHOUT WATER, WASTED PIECES OF CONCRETE, AND ALL OTHER DEBRIS IN THE PIT SHALL BE REMOVED FROM THE JOB SITE.
4. THE CWA SHALL REMAIN IN PLACE UNTIL ALL CONCRETE FOR THE PROJECT IS PLACED.
5. WHEN THE CWA IS REMOVED, COVER THE DISTURBED AREA WITH TOP SOIL. SEED AND MULCH OR OTHERWISE STABILIZED IN A MANNER APPROVED BY THE LOCAL JURISDICTION.

LAST REVISION DATE: FEB 2021	JO # STANDARD
TEMPORARY CONCRETE WASHOUT AREA (CWA) (NTS)	
AUMSVILLE, OR	DETAIL NO. 616

N.T.S.

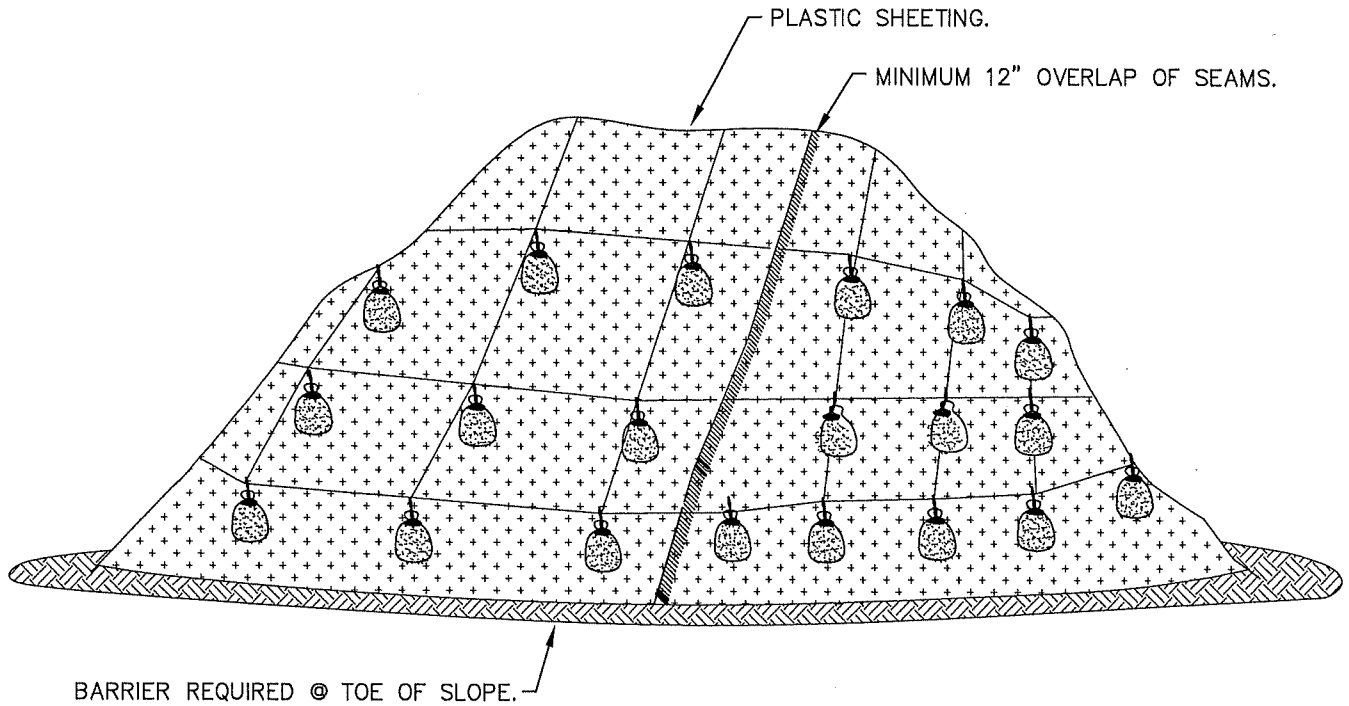

STOCKPILE DETAIL

NOTES:

1. MINIMUM 12" OVERLAP OF ALL SEAMS REQUIRED.
2. SEDIMENT BARRIER REQUIRED @ TOE OF STOCK PILE.
3. COVERING MAINTAINED TIGHTLY IN PLACE BY USING SANDBAGS OR TIRES ON ROPES WITH A MAXIMUM 10' GRID SPACING IN ALL DIRECTIONS.
4. PLASTIC SHEETING TO EXTEND A MINIMUM OF 12" PAST THE BOTTOM OF THE PILE ONTO SURROUNDING GRADE ON ALL SIDES.

LAST REVISION DATE: FEB 2021	JO # STANDARD
STOCKPILE COVER DETAIL (NTS)	
AUMSVILLE, OR	DETAIL NO. 617